

Appendix C

Design Drawings Specifications



Appendix C – Drawings and Details

Table of Contents

1.0	General	1
	A-100 Legend	1
	B-100 Lot Grading and Drainage Details (1/2)	2
	B-101 Lot Grading and Drainage Details (2/2)	3
	C-G-100 Project Construction Sign	4
	D-100 Service Record Drawing.....	5
2.0	Roadway	6
	C-R-100 (T) Road Cross Section – Typical Street 20.0 m R.O.W	6
	C-R-100 (C) Road Cross Section – Commercial Street 20.0 m R.O.W.	7
	C-R-100 (I) Road Cross Section – Industrial Street 20.0 m R.O.W.	8
	C-R-100 (CUL) Road Cross Section – Cul-de-Sac 20.0 m R.O.W.....	9
	C-R-101 (A) Road Cross Section – Arterial Street 30.0 m R.O.W.	10
	C-R-102 Appurtenances Paving Details	11
	C-R-103 Direct Buried Conduits Under Roadways	12
	C-R-104 Direct Buried Duct Detail Under Sidewalk.....	13
	C-R-105A 150 mm Curb And 250 mm Gutter	14
	C-R-105B 150mm Barrier Curb & Reverse Gutter	15
	C-R-105C 200mm Barrier Curb & Reverse Gutter	16
	C-R-106A Rollface Curb & Gutter – Concrete Sidewalk.....	17
	C-R-106B Rollface Curb & Gutter – Asphalt Sidewalk	18
	C-R-106C Rollface Curb.....	19
	C-R-107 Curb And Gutter Termination	20
	C-R-108 Catch Basin Curb And Gutter Tie-in.....	21
	C-R-109 Monolithic Curb, Gutter & Sidewalk 150 mm Barrier Curb	22
	C-R-110A Multi-use Pathway and Concrete Swales	23
	C-R-110 Separate Sidewalk	24
	C-R-111 Sidewalk Joint And Finishing.....	25
	C-R-112 Pin Walk Detail For Lane.....	26
	C-R-113 Walk Poured Separate From 150 mm Barrier Curb And Gutter	27
	C-R-114 Para-Ramp	28



	C-R-114A	Para-Ramp at Signalized Intersection.....	29
	C-R-115	Utility Isolation In Sidewalks	30
	C-R-116	Guard Rail Plan And Elevation	31
	C-R-117	Typical Parallel Street Parking.....	32
	C-R-117A	Parking Markings (Reference).....	33
	C-R-118	Bus Pullout Layout.....	34
	C-R-118A	Bus Pullout Layout (Reference).....	35
	C-R-118B	Bus Shelter (Reference).....	36
3.0	Sanitary		37
	C-S-100	Precast Manhole	37
	C-S-101	Typical Precast Manhole Installation	38
	C-S-102	Typical Insulated Manhole.....	39
	C-S-103	Standard Shaping Of Manhole Bottoms	40
	C-S-104	Standard Manhole Frame And Cover F-39	41
	C-S-105	Insulated Sanitary Sewer – Bell & Spigot Joint	42
	C-S-106	Flanged Joint Detail	43
	C-S-107	Typical Welded Joint Detail	44
	C-S-108	Typical Sanitary Sewer Bedding	45
	C-S-109	Sanitary Manhole Frost Cover Lid	46
4.0	Storm		47
	C-ST-100	Typical Storm Sewer Bedding	47
	C-ST-101	Concrete Catch Basin.....	48
	C-ST-102	Double 600mmx600mm Pre-Cast Catch Basin Installation	49
	C-ST-104	Type NF-51 Catch Basin Frame and Cover.....	50
	C-ST-105	1200 \varnothing Manhole – Alternative No.1 For Storm Pipes 550 mm \varnothing or Less	51
	C-ST-106	Subgrade Drain Tie-in	52
	C-ST-107	Subgrade Drain Tie-in Section A-A	53
	C-ST-108	Shallow Catch Basin.....	54
	C-ST-109	Shallow Cover Cast In Place	55
	C-ST-110	Catch Basin Lead To Main Connection	56
	C-ST-111	Typical Culvert Installation With Rip Rap End Treatment	57
	C-ST-112	Joint Detail	58
	C-ST-113	Storm Drain Outfall	59
	C-ST-114	Double Culvert Wing-Wall Detail	60

















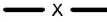

	C-ST-115	Culvert Wing-Wall Side View	61
	C-ST-116	Rainfall Intensity I-D-F Curve	62
5.0	Trench		63
	C-T-100	Typical Trench Section	63
	C-T-101	Typical Common Trench Detail Sanitary And Watermain	64
	C-T-102	Trench Rock Excavation Measurements – Mains	65
	C-T-103	Trench Rock Excavation Measurements – Services	66
	C-T-104	Shallow Utility Trench Detail.....	67
6.0	Water		68
	C-W-100	Typical Watermain Bedding.....	68
	C-W-101	Gooseneck/Main Stop Insulation Detail At Water Main	69
	C-W-102	Circulation Pump Installation Detail.....	70
	C-W-103	Orifice Installation Detail	71
	C-W-104	Typical Building Circulation Pump & Meter Installation.....	72
	C-W-105	Water Manhole – Section A.....	73
	C-W-106	Water Manhole – Slab Reinforcement.....	74
	C-W-107	Water Manhole – Roof Slab Plan	75
	C-W-108	Water Manhole – Section C	76
	C-W-109	Frost Cover Plan	77
	C-W-110	Frost Cover – Section D	78
	C-W-111	Frost Cover Detail.....	79
	C-W-112	Water Manhole – Lifting Hooks	80
	C-W-113	Water Manhole – Typical 200 mm Corner Bar Enforcement	81
	C-W-114	Water Manhole – Typical Reinforcement Around Wall Openings.....	82
	C-W-115	Water Manhole – Pipe Support	83
	C-W-116	Water Manhole – Typical Pipe Through Wall	84
	C-W-117	List of Components	85
	C-W-118	Water Vault – 200 mm ϕ Main (AV1)	86
	C-W-119	Water Vault – 200 mm ϕ Main (HV2)	87
	C-W-120	Water Vault – 200 mm ϕ Main (HV3)	88
	C-W-121	Water Vault – 200 mm ϕ Main (HV4)	89
	C-W-122	Detail Connection To MH. Wall.....	90
	C-W-123	Underground Pipe Clamps Detail.....	91
	C-W-124	Insulated Pipe Clamping (Top And Side).....	92



	C-W-125	Insulated Watermains – Bell & Spigot Joint	93
	C-W-126	Reaction Blocking A	94
	C-W-127	Reaction Blocking B	95
	C-W-128	Typical Single Valve Installation	96
	C-W-129	Hydrant Through Roof & Concrete Water Manhole Cover	97
7.0	Service		98
	C-SE-100	Service Plan.....	98
	C-SE-101	Typical Service and Driveway Layout	99
	C-SE-102A	Typical Service Connection to Lots.....	100
	C-SE-102B	Typical Service Connection to Lots.....	101
	C-SE-103	Gooseneck Main Stop Insulation at Watermain	102
	C-SE-104	Typical Separate Water Service	103
	C-SE-105	Typical Combined Water-Sewer Service Trench Details	104
	C-SE-106	Service Pipe Insulation Detail	105
	C-SE-107	Sanitary Sewer Main And Service Detail	106
	C-SE-108	Sanitary Sewer Service and Connection Detail	107
8.0	Pavement Markings		109
	PM 100	Pavement Markings Legend	109



GENERAL

	DIRECTION OF FLOW
	PLUG
	FILTER CLOTH
	ROCK
	POWER POLE
	LIGHT STANDARD
	SUPER MAILBOX
	FENCE
	ABANDONED MAIN
	CULVERT
	OVERHEAD UTILITY
	UNDERGROUND UTILITY
	REMOVE COMPLETELY, PLUG ABANDONED PIPES WITH CONCRETE.
	INDICATES A TIE TO EXISTING CONTRACTOR IS RESPONSIBLE FOR VERIFYING ELEVATION AND LOCATION PRIOR TO CONSTRUCTION.
	PROPOSED CONDUIT
	PROPOSED ELEVATION
	LIP OF GUTTER

① 45° BEND

② 22 1/2° BEND

③ 90° BEND

④ 11 1/2° BEND























① INSULATED SEWER SERVICE

Ⓐ ASPHALT DRIVEWAY

Ⓒ CONCRETE DRIVEWAY

Ⓓ GRAVEL DRIVEWAY

LEGEND

	PROPOSED	EXISTING
SANITARY SEWER (SAN)		
STORM SEWER (STW)		
WATERMAIN (WAT)		
FORCEMAIN		
CLAMPING		
WATER & SEWER SERVICE		
MANHOLE		
CATCHBASIN		
VALVE		
HYDRANT VAULT (HV)		
WATER MANHOLE (WMH)		



N.T.S.

DATE DRAWN:
01/01/2020

REVISION DATE:
06/04/2022

APPROVED BY:
YK ENG.

TITLE:

LEGEND

GENERAL

REVISION No.
1

DWG.No.

A-100

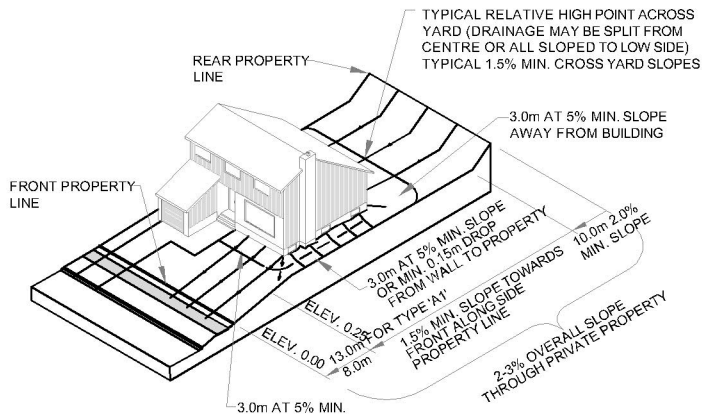

2-3% OVERALL LOT SLOPE

TYPE 'A' & TYPE 'A1' REAR TO FRONT DRAINAGE

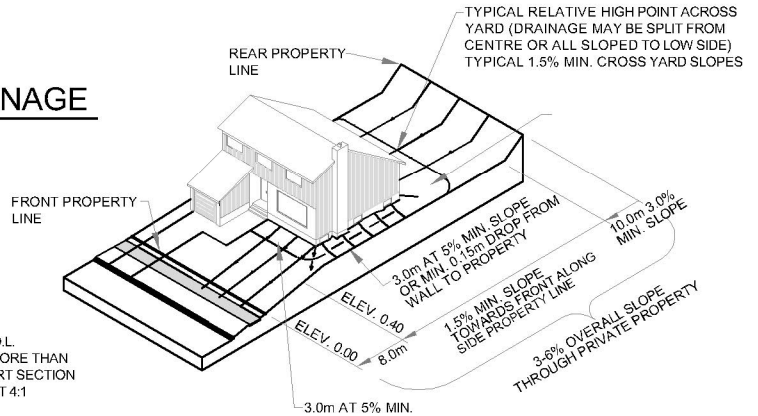

3-6% OVERALL LOT SLOPE

TYPE 'B' REAR TO FRONT DRAINAGE

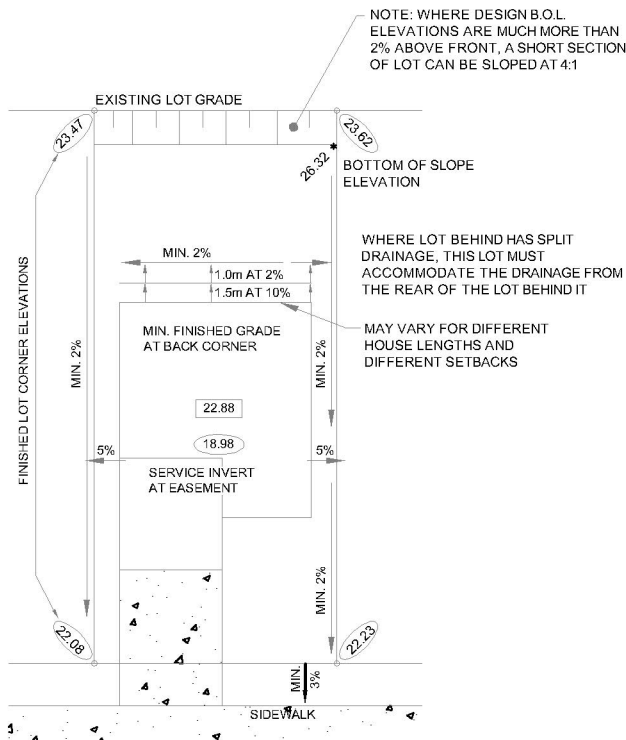

REAR TO FRONT DRAINAGE TYPICAL DETAIL



N.T.S.

TITLE:

LOT GRADING AND DRAINAGE DETAILS (1/2)

DATE DRAWN:

01/01/2020

REVISION DATE:

06/04/2022

APPROVED BY:

YK ENG.

GENERAL

REVISION No.

1

DWG.No.

B-100

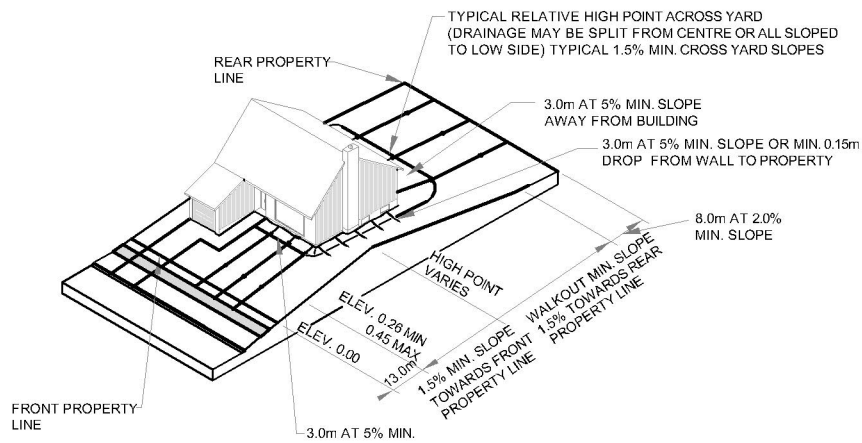

TYPE 'W' SPLIT DRAINAGE

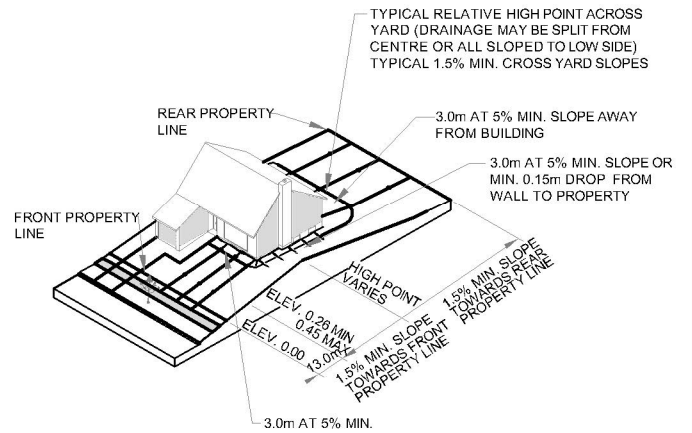

TYPE 'D' STANDARD SPLIT DRAINAGE

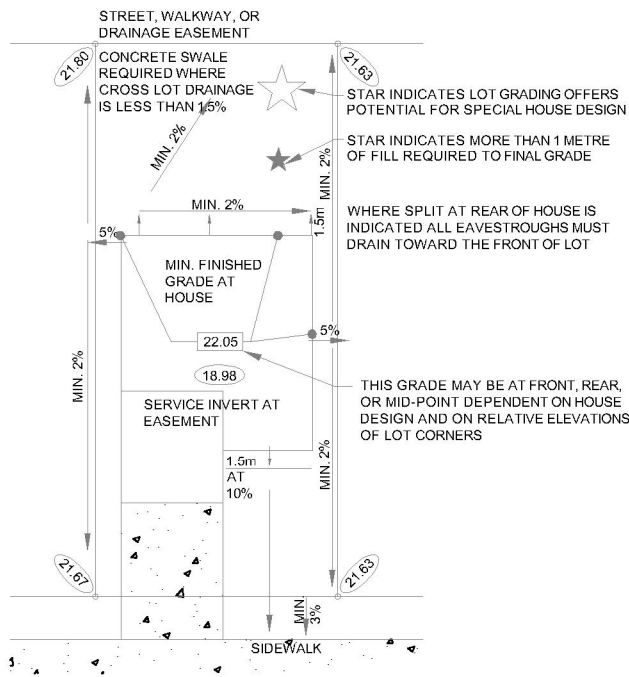

SPLIT DRAINAGE TYPICAL DETAIL



N.T.S

DATE DRAWN:
01/01/2020

REVISION DATE:
06/04/2022

APPROVED BY:
YK ENG.

TITLE:

LOT GRADING AND DRAINAGE DETAILS (2/2)

GENERAL

REVISION No.
1

DWG.No.

B-101

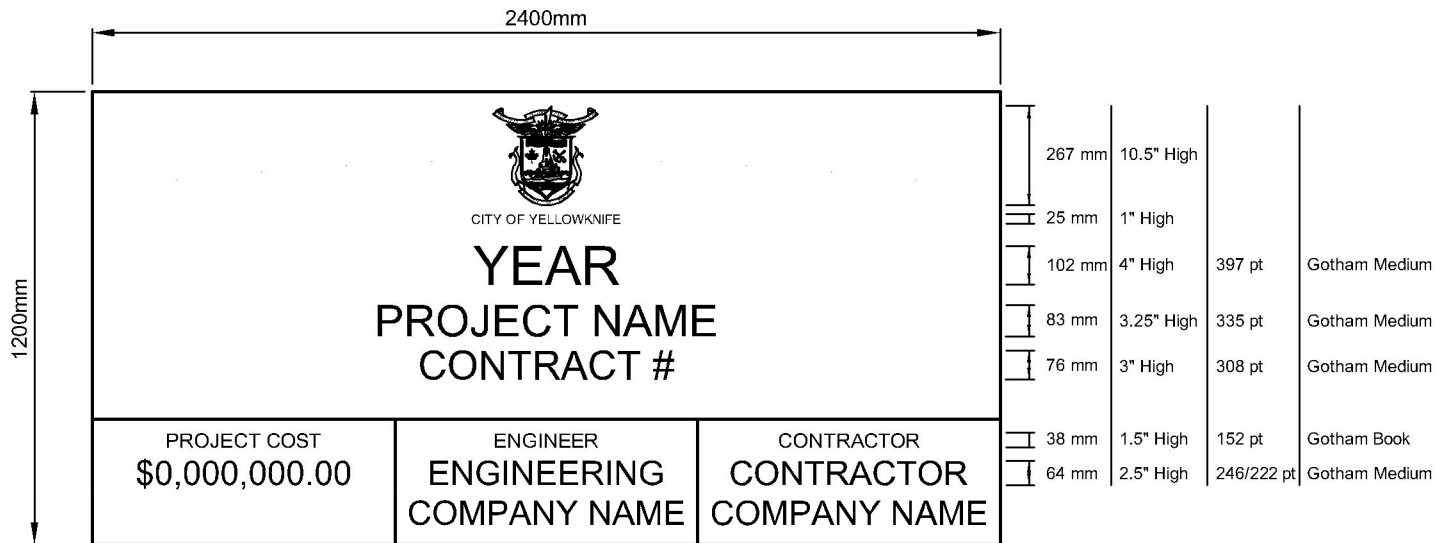

PROJECT CONSTRUCTION SIGN
SCALE 1:20

NOTES:

1. SIGN LAYOUT AND LETTERING TO CITY OF YELLOWKNIFE SIGNAGE STANDARDS.
2. PROVIDE AND ERECT A PROJECT SIGN IN A LOCATION DESIGNATED BY THE ENGINEER.
3. SIGN SHALL BE 1200 mm X 2400 mm (96" X 48"), 3 MIL WHITE DIBOND OR ALTERNATE APPROVED BY THE CITY.
4. SIGN TEMPLATE WILL BE PROVIDED, IN AN EDITABLE ADOBE ILLUSTRATION AI FILE.
5. PROVIDE ADEQUATE SUPPORTING FRAMEWORK FOR THE SIGN.
6. TEXT INFORMATION AS PER DETAIL ON DRAWINGS AND ENGINEER'S INSTRUCTIONS. TEXT TO BE APPLIED USING CUT VINYL OR DIGITAL, LAMINATED PRINT.
7. MAINTAIN SIGN IN GOOD CONDITION FOR THE DURATION OF THE THE WORK. CLEAN PERIODICALLY.
8. DISMANTLE SIGN WITH CARE AND DELIVER TO OWNER AT COMPLETION OF PROJECT.
9. NO OTHER SIGNS OR ADVERTISEMENTS OTHER THAN WARNING SIGNS ARE TO BE ERECTED ON SITE.

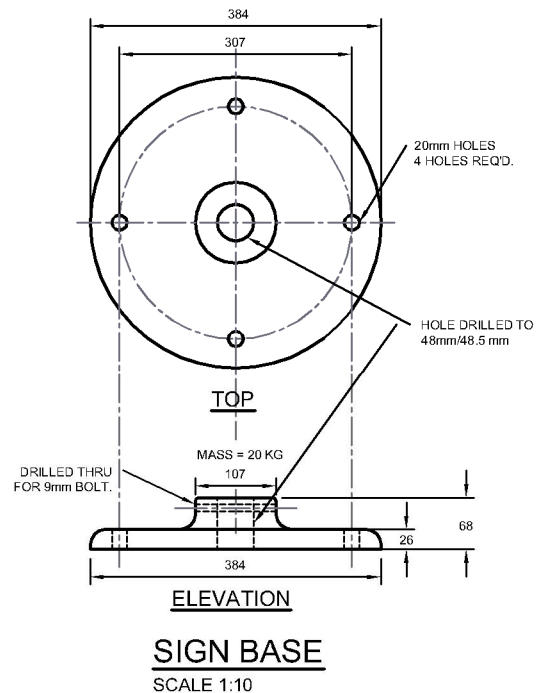

AS SHOWN	
DATE DRAWN: 01/01/20	REVISION DATE: 06/04/2022
APPROVED BY: YK ENG.	

TITLE: PROJECT CONSTRUCTION SIGN		
GENERAL	REVISION No. 1	DWG.No. C-G-100

ADDRESS _____
 EX. SERVICE - SAN _____
 - WAT _____

HEAT TRACE
 BLEEDER

DATE INSTALLED _____
 DATE ON TEMP _____
 DATE OFF TEMP _____

METER INFORMATION
 NEW - SER # _____
 OLD - SER # _____
 NEW READING _____
 OLD READING _____

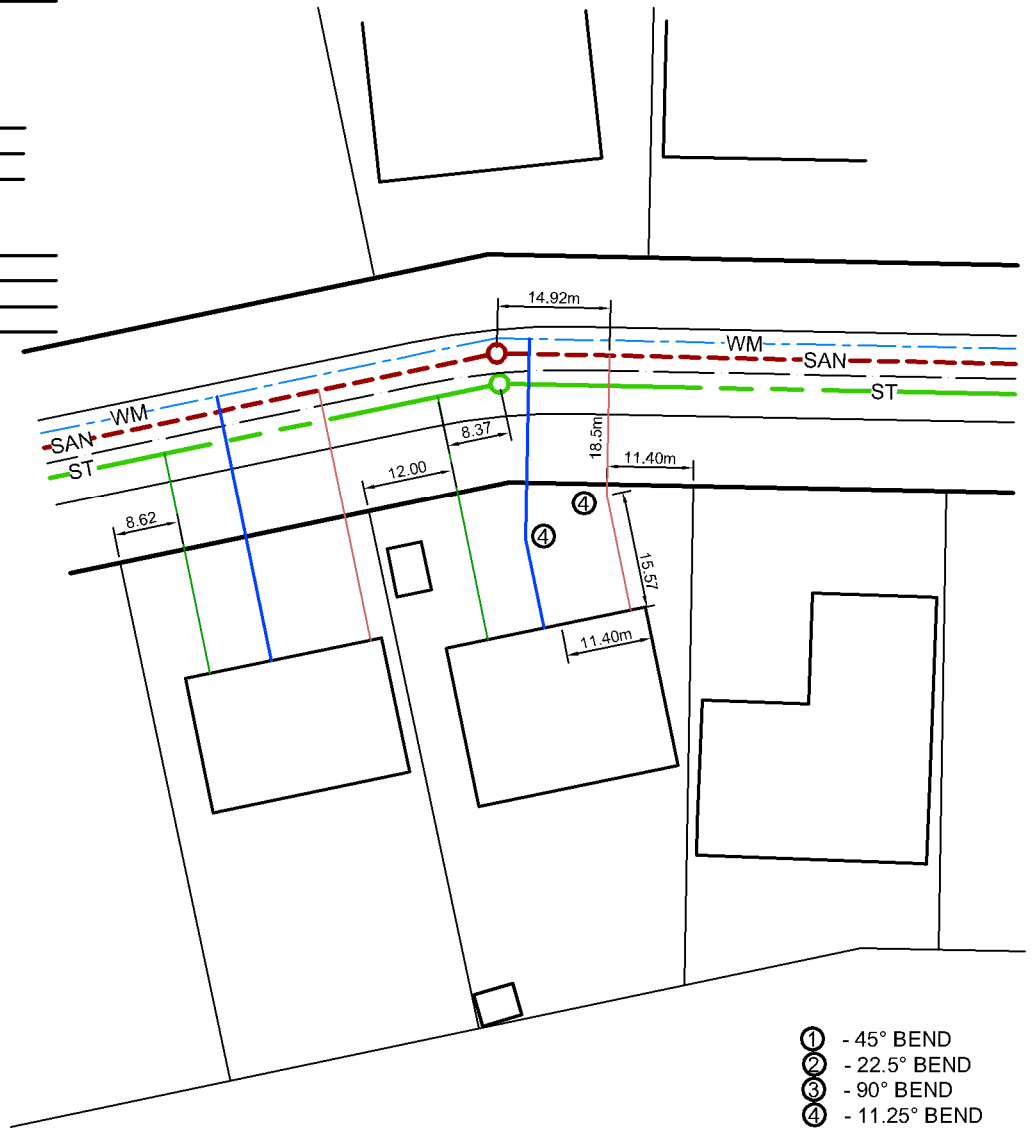

- ① - 45° BEND
- ② - 22.5° BEND
- ③ - 90° BEND
- ④ - 11.25° BEND

NOTE:
 IN AREAS WHERE EXISTING CONDITIONS REQUIRE A VARIANCE IN ALIGNMENT (AS PER EXAMPLE) INDICATE AND DIMENSION ANY AND ALL VARIANCES FROM ALIGNMENTS. DIMENSIONS CAN BE FROM ANY PERMANENT STRUCTURE OR PROPERTY LINE.

ELEVATIONS

TOP SEWER @		
MAIN	_____	GROUND _____
BEND 1	_____	GROUND _____
BEND 2	_____	GROUND _____
BEND 3	_____	GROUND _____
PROP. LINE	_____	GROUND _____
TIE-IN	_____	GROUND _____

TOP WAT @ MAIN _____

NOTE: FOR CLARITY THIS EXAMPLE INDICATES TWO LOCATIONS, HOWEVER CONTRACTOR WILL PROVIDE SEPARATE SHEETS FOR EACH INDIVIDUAL SERVICE.



N.T.S.

DATE DRAWN: 01/01/20	REVISION DATE: 06/04/2022
APPROVED BY: YK ENG.	

TITLE: SERVICE RECORD DRAWING

GENERAL	REVISION No. 1	DWG.No. D-100
---------	-------------------	------------------

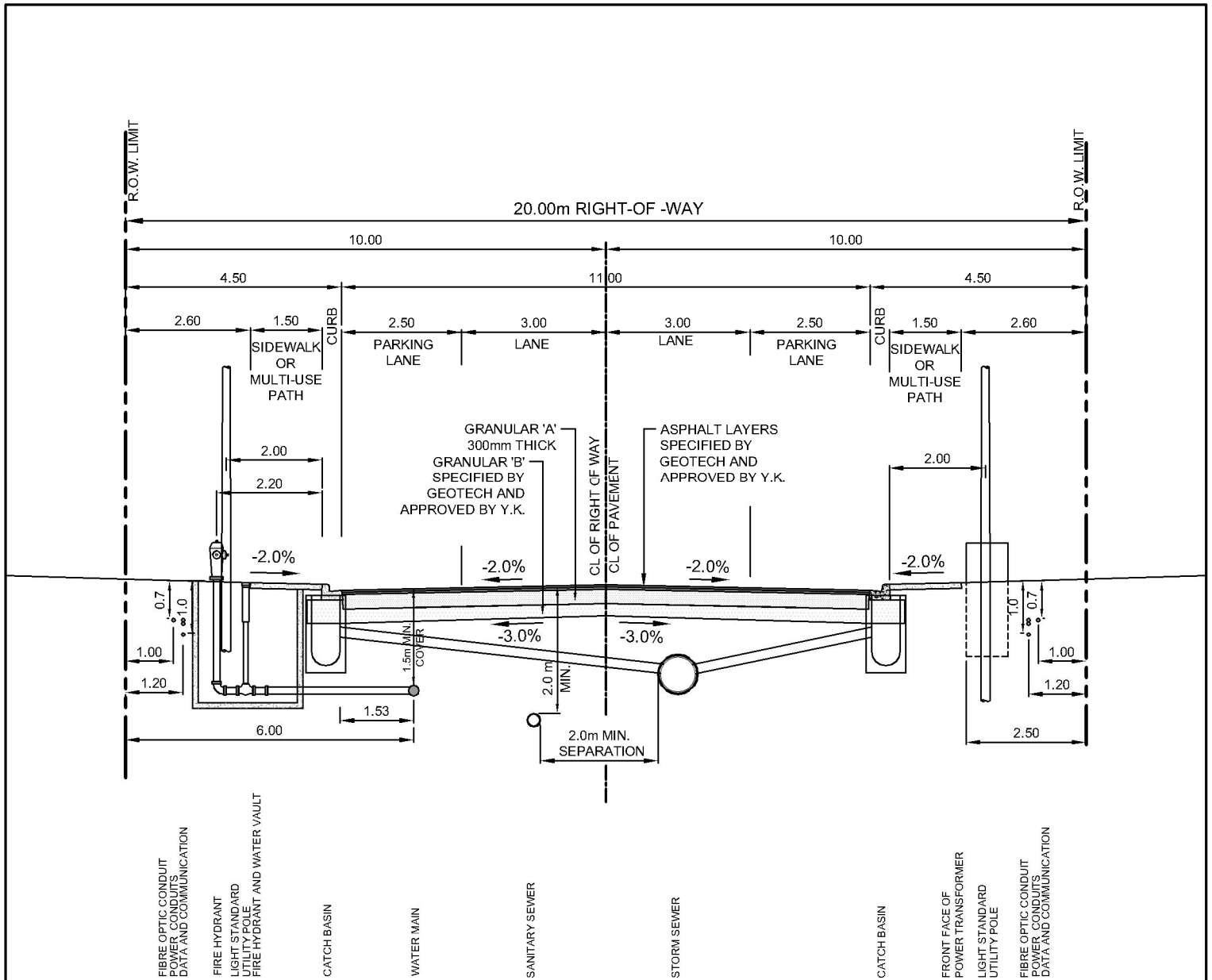

NOTES:

1. THE ABOVE CROSS SECTION IS INTENDED TO BE A GUIDELINE FOR LOCATION OF UTILITY CORRIDORS WITHIN NEW SUBDIVISIONS AND ROADWAYS. THE CORRIDOR LOCATIONS SHOULD ALSO BE CONSIDERED WHERE POSSIBLE WHEN NEW UTILITY PLANTS ARE TO BE CONSTRUCTED WITHIN EXISTING ROAD ALLOWANCES.
2. VERTICAL DIMENSIONS TO UTILITY PLANT ARE GUIDELINES ONLY AND SHOULD BE CONFIRMED WITH THE UTILITY COMPANY. DIMENSIONS SHOWN ARE TO TOP OF FINISHED GRADE, AND IT IS THEREFORE ESSENTIAL THAT GRADING BE COMPLETED TO OUTER EDGE OF RIGHT-OF-WAY BEFORE UTILITY INSTALLATION AND BE WITHIN 15cm OF FINAL GRADE.
3. NO TWO (2) ABOVE GROUND UTILITIES ON THE SAME LOT FRONTAGE.
4. POWER CONDUITS, FIBRE OPTIC AND DATA & COMMUNICATION CONDUITS TO BE INSTALLED IN JOINT TRENCH.
5. SIDEWALK TO BE 1.50m WIDTH ONE SIDE OF R.O.W. ONLY FOR LOCAL STREETS. SIDEWALK TO BE 1.50m WIDTH BOTH SIDES OF R.O.W. FOR COLLECTOR AND ARTERIAL STREETS.



1:125	
DATE DRAWN: 24/03/2021	REVISION DATE: 06/04/2022
APPROVED BY: YK.ENG.	

TITLE: ROAD CROSS SECTION - TYPICAL STREET 20.0m R.O.W.	
ROADWAY	REVISION No. 1
	DWG.No. C-R-100 (T)

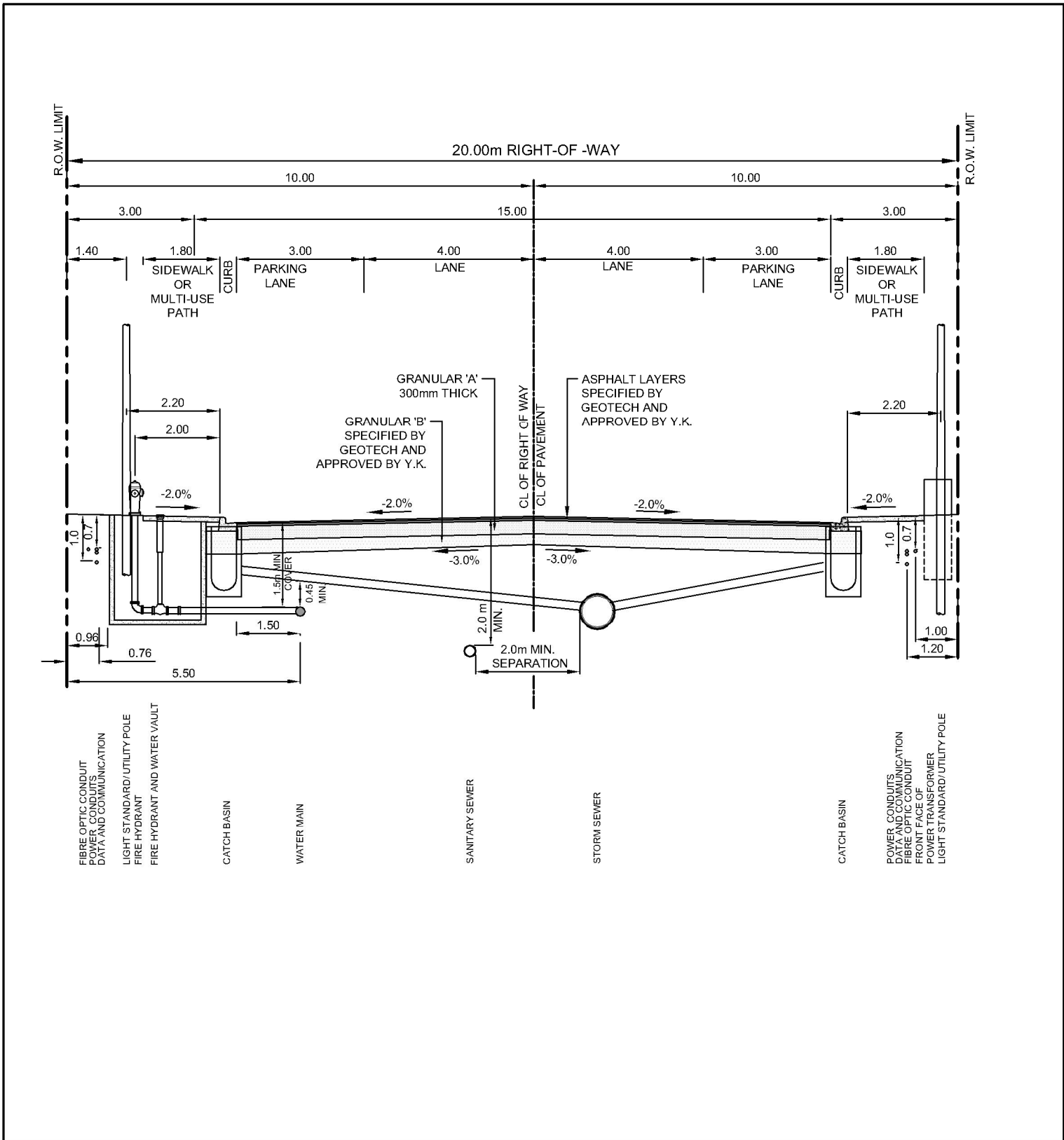

1:125

DATE DRAWN:
03/24/2021

REVISION DATE:
06/04/2022

APPROVED BY:
YK ENG.

TITLE:

**ROAD CROSS SECTION - COMMERCIAL
STREET 20.0m R.O.W.**

ROADWAY

REVISION No.
1

DWG.No.

C-R-100 (C)

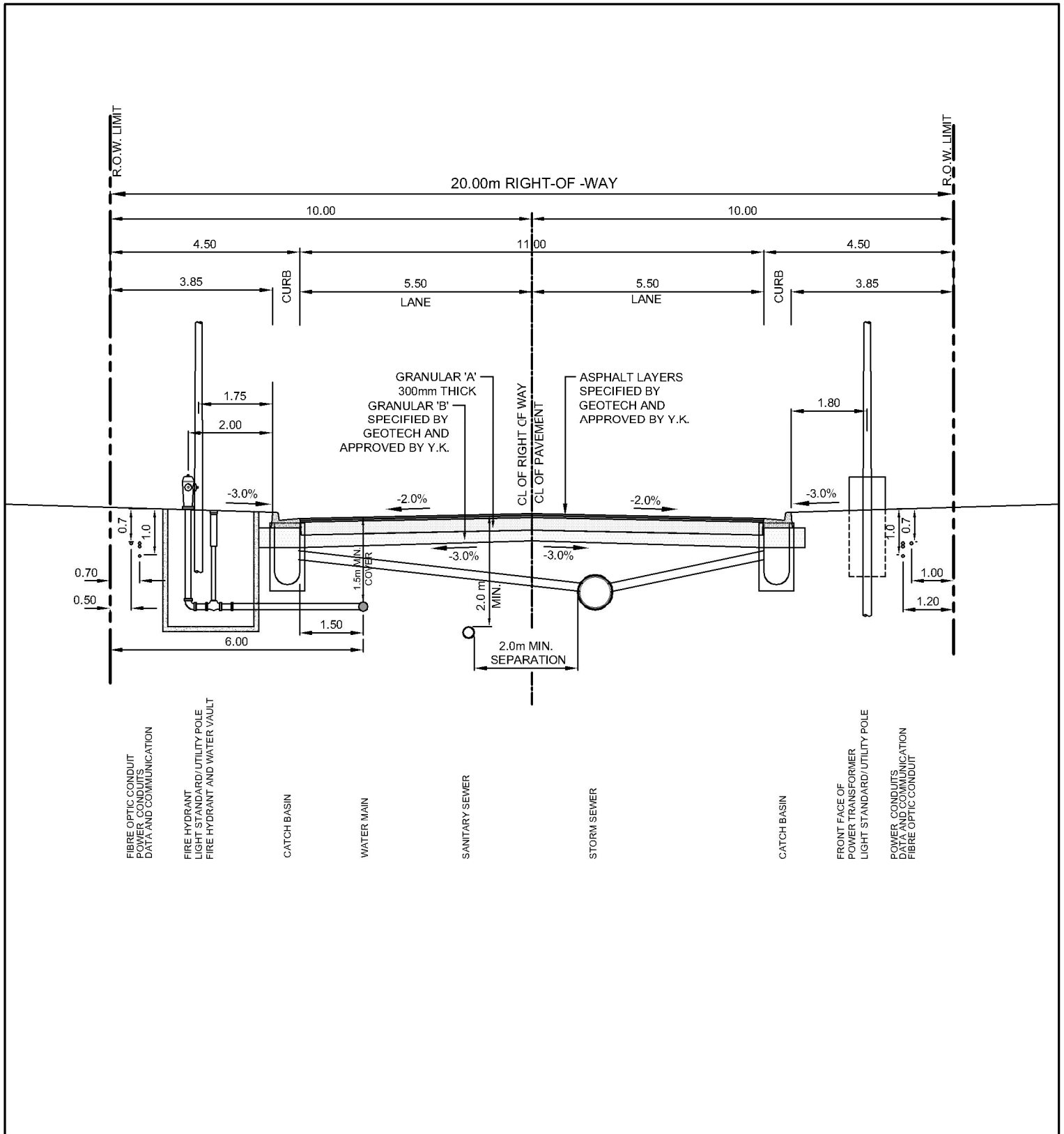

1:125	
DATE DRAWN: 24/03/2021	REVISION DATE: 06/04/2022
APPROVED BY: YK ENG.	

TITLE: ROAD CROSS SECTION - INDUSTRIAL STREET 20.0m R.O.W.		
ROADWAY	REVISION No. 1	DWG.No. C-R-100 (I)

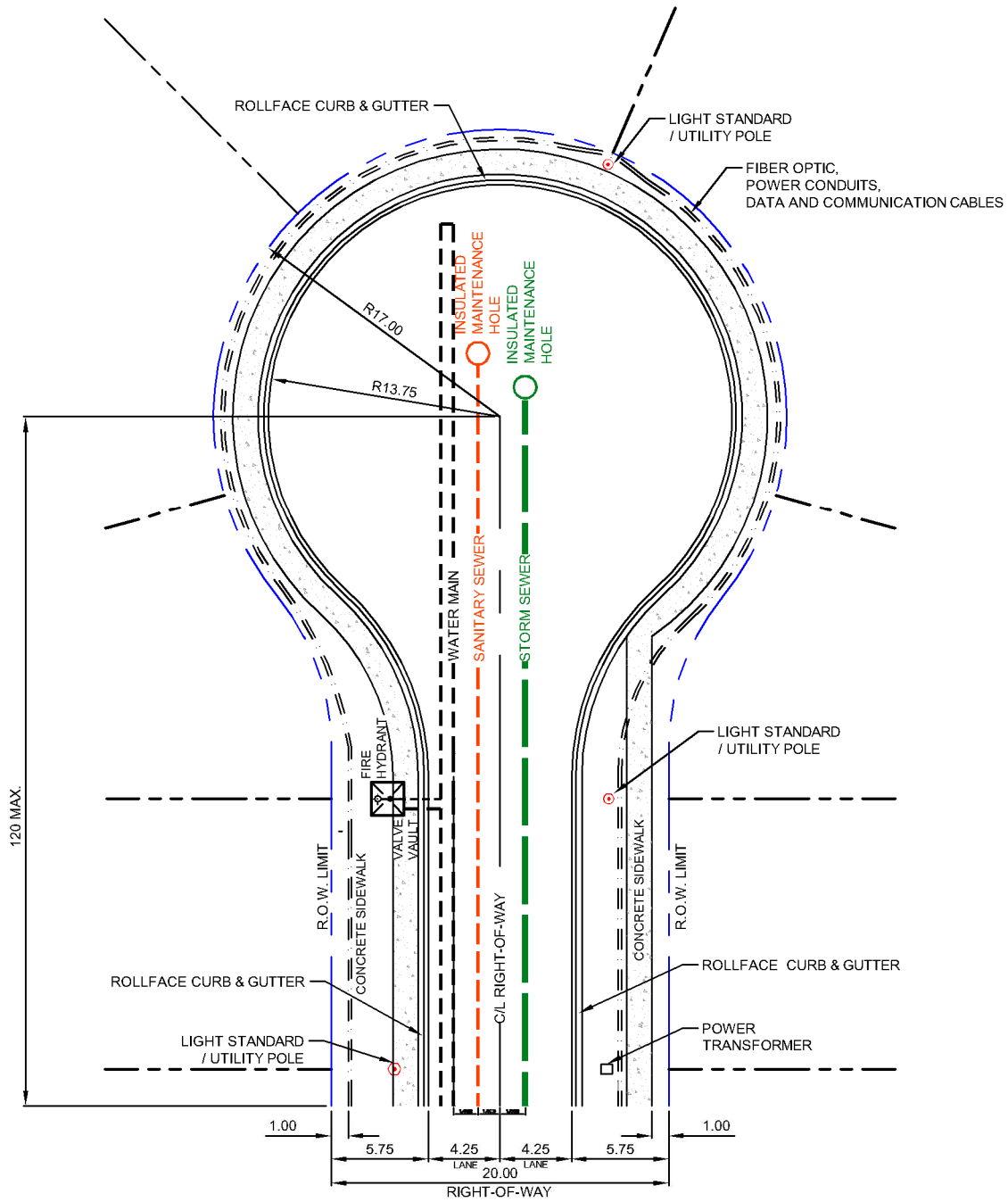

NOTES:

1. THE ABOVE IS INTENDED TO BE A GUIDELINE FOR LOCATION OF UTILITY CORRIDORS WITHIN NEW SUBDIVISIONS AND ROADWAYS. THE CORRIDOR LOCATIONS SHOULD ALSO BE CONSIDERED WHERE POSSIBLE WHEN NEW UTILITY PLANTS ARE TO BE CONSTRUCTED WITHIN EXISTING ROAD ALLOWANCES.
2. REFER TO STANDARD UTILITY CROSS SECTION DRAWINGS FOR VERTICAL AND HORIZONTAL DIMENSIONING TO EACH UTILITY PLANT.
3. NO TWO (2) ABOVE GROUND UTILITIES ON THE SAME LOT FRONTAGE.
4. FIBER OPTIC, POWER CONDUITS, DATA AND COMMUNICATION CABLES TO BE INSTALLED IN JOINT TRENCH.
5. SIDEWALK TO BE 1.50m WIDTH ONE SIDE OF R.O.W. ONLY FOR LOCAL STREETS. SIDEWALK TO BE 1.50m WIDTH BOTH SIDES OF R.O.W. FOR COLLECTOR AND ARTERIAL STREETS.
6. CONSIDERATION SHALL BE MADE FOR LOCATIONS OF DRIVEWAY ENTRANCES WHEN LOCATING ABOVE GROUND UTILITIES ON LOT FRONTAGES.



1:400

DATE DRAWN:
31/03/2021

REVISION DATE:
06/04/2022

APPROVED BY:
YK ENG.

TITLE:

**ROAD CROSS SECTION - CUL-de-SAC 20.0m
R.O.W**

ROADWAY

REVISION No.
1

DWG.No.
C-R-100 (CUL)

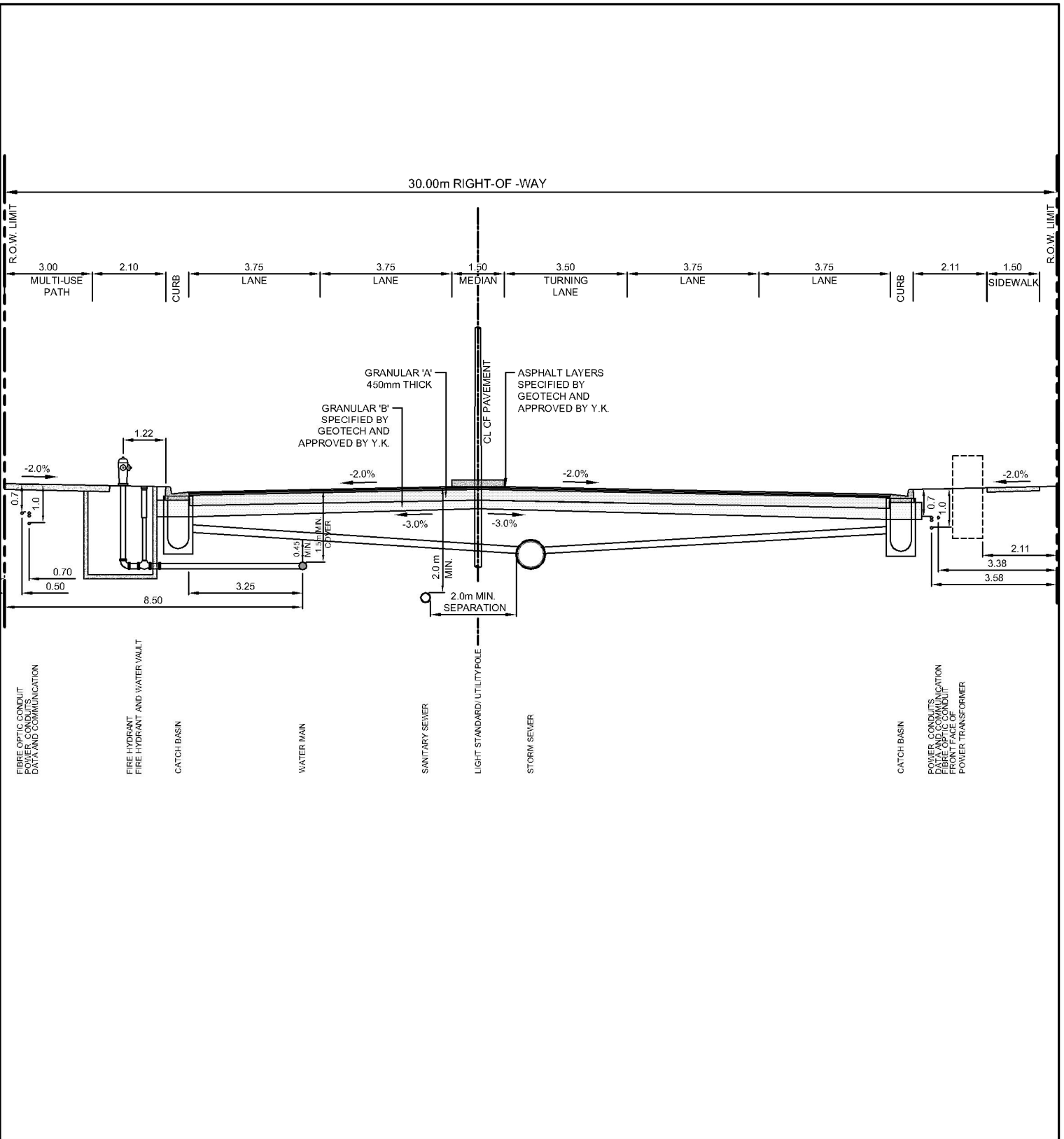

1:175

DATE DRAWN:
24/03/2021

REVISION DATE:
06/04/2022

APPROVED BY:
YK ENG.

TITLE:

TYPICAL ROAD CROSS SECTION
ARTERIAL STREET
30m ROW

ROADWAY

REVISION No.
1

DWG.No.

C-R-101 (A)

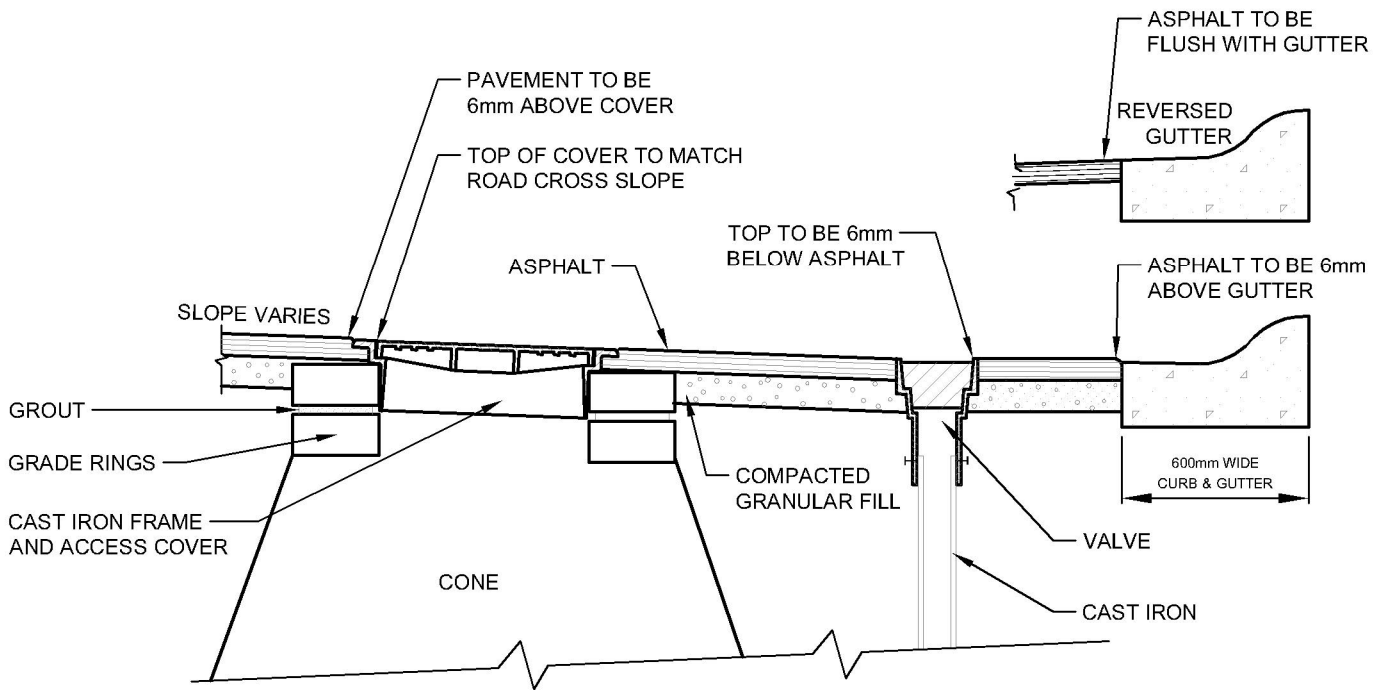

ALL DIMENSIONS ARE IN MILLIMETERS UNLESS NOTED OTHERWISE



1:15

DATE DRAWN:
01/01/20

REVISION DATE:
06/04/2022

APPROVED BY:
YK ENG.

TITLE:

APPURTENANCES PAVING DETAILS

ROADWAY

REVISION No.
1

DWG.No.

C-R-102

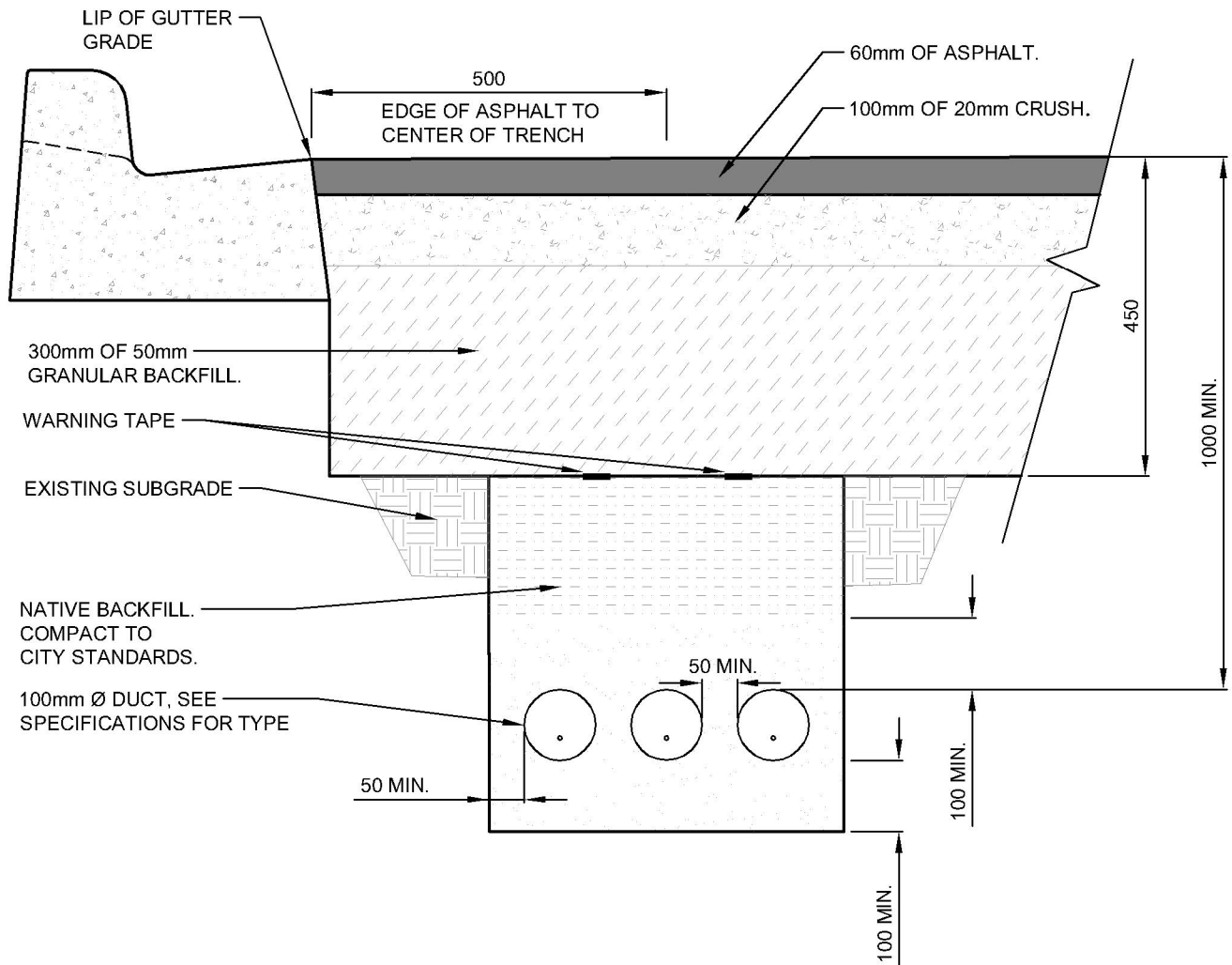

ALL DIMENSIONS ARE IN MILLIMETERS UNLESS NOTED OTHERWISE



1:10	
DATE DRAWN: 01/01/20	REVISION DATE: 06/04/2022
APPROVED BY: YK ENG.	

TITLE: DIRECT BURIED CONDUITS UNDER ROADWAYS		
ROADWAY	REVISION No. 1	DWG.No. C-R-103

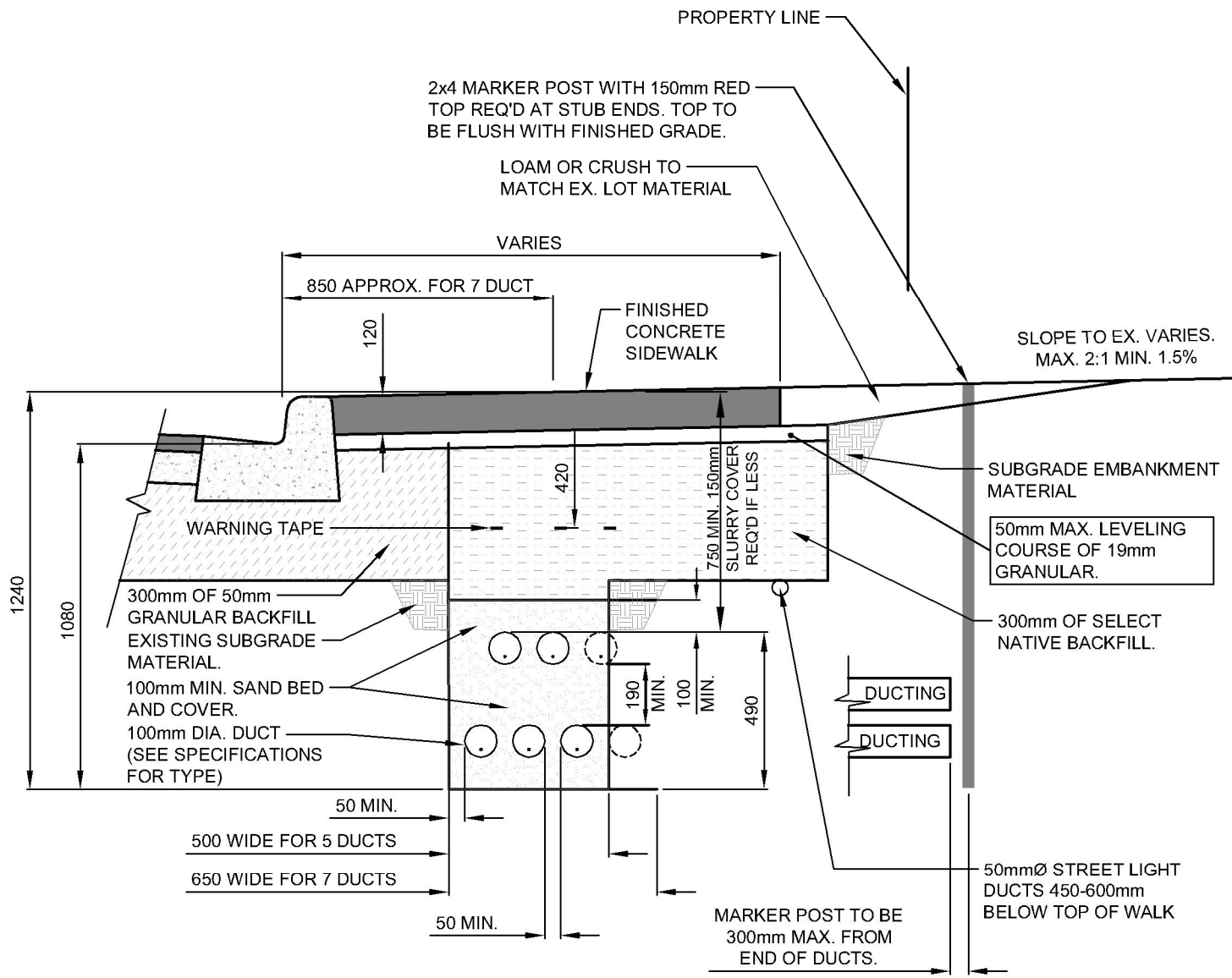

1:20	
DATE DRAWN: 01/01/20	REVISION DATE: 06/04/2022
APPROVED BY: YK ENG.	

TITLE: DIRECT BURIED DUCT DETAIL UNDER SIDEWALK		
ROADWAY	REVISION No. 1	DWG.No. C-R-104

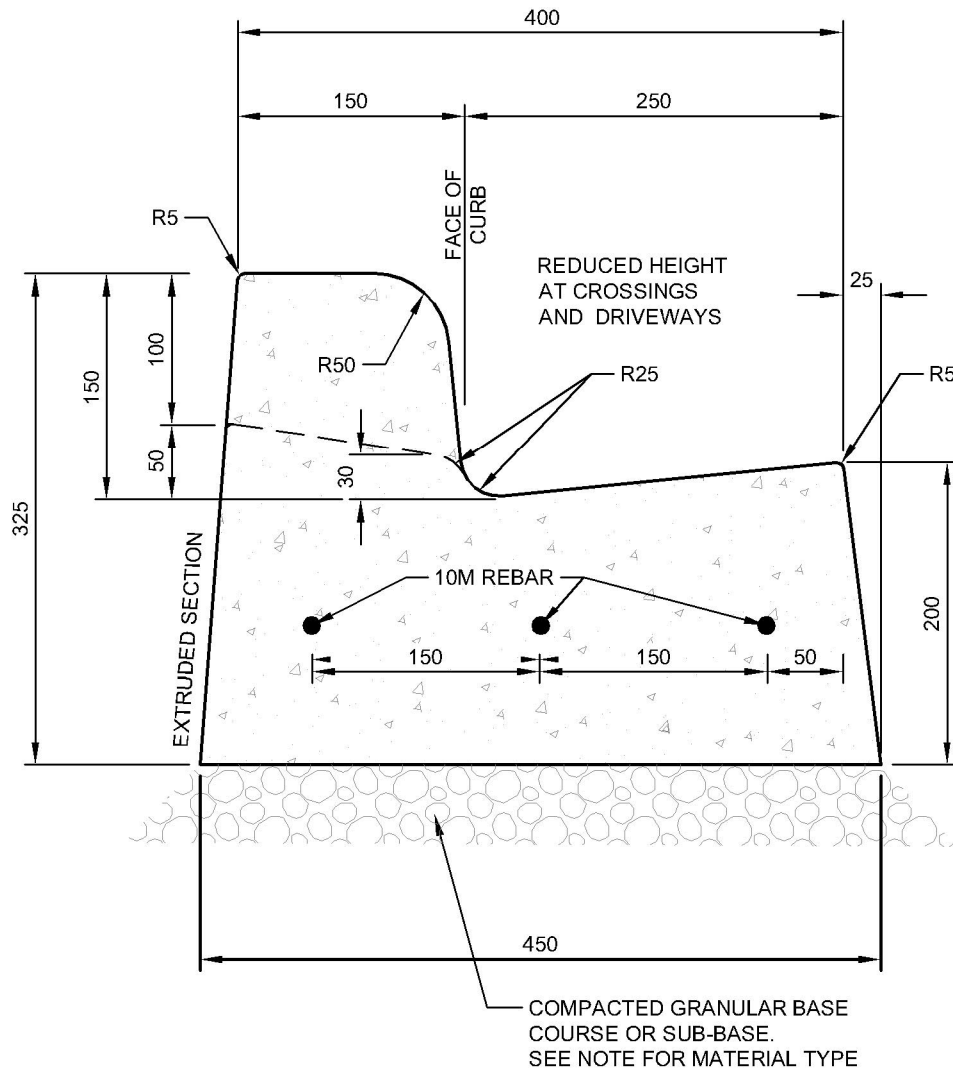

NOTES:

1. REDUCED CURB HEIGHT AT ALL CROSSINGS AND DRIVEWAYS.
2. 3-10M REBAR AT ALL LANE AND COMMERCIAL CROSSINGS.
3. PREFERRED MATERIAL FOR BASE COURSE IS NATIVE MATERIAL.
4. CONTACT ENGINEER FOR APPROVAL OF IMPORTED GRANULAR MATERIAL IF THERE IS NO SUITABLE NATIVE MATERIAL.
5. CONTACT ENGINEER IF UNSUITABLE BASE CONDITIONS ARE ENCOUNTERED.
6. ALL DIMENSIONS IN MILLIMETERS UNLESS NOTED OTHERWISE



1:5

DATE DRAWN:
01/01/20

REVISION DATE:
06/04/2022

APPROVED BY:
YK ENG.

TITLE:

150mm BARRIER CURB AND 250mm GUTTER

ROADWAY

REVISION No.
1

DWG.No.

C-R-105A

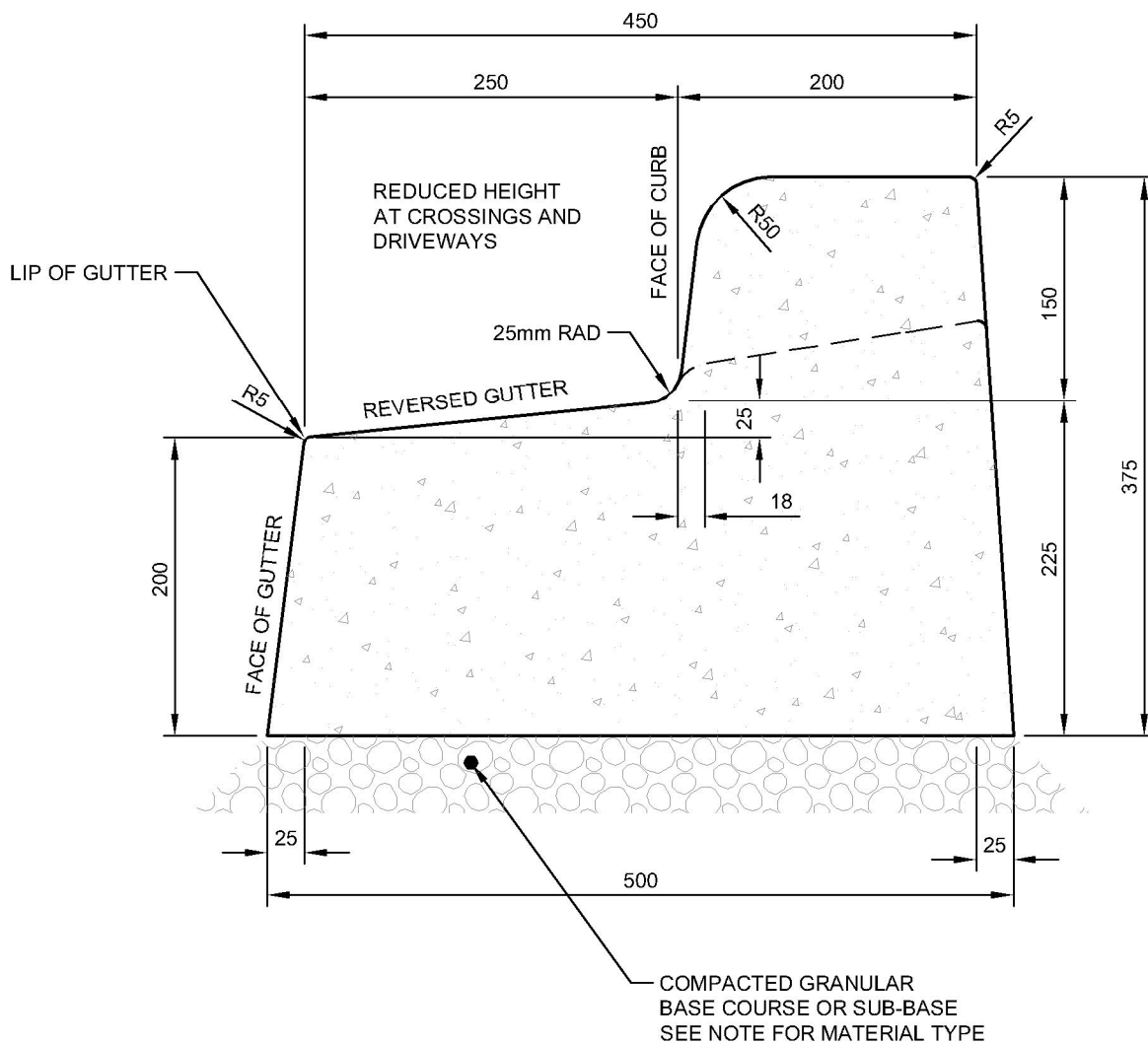

NOTES:

1. PREFERRED MATERIAL FOR BASE COURSE IS NATIVE MATERIAL.
2. CONTACT ENGINEER FOR APPROVAL OF IMPORTED GRANULAR MATERIAL IF THERE IS NO SUITABLE NATIVE MATERIAL.
3. CONTACT ENGINEER IF UNSUITABLE BASE CONDITIONS ARE ENCOUNTERED.



1:5

DATE DRAWN:
01/01/20

REVISION DATE:
06/04/2022

APPROVED BY:
YK ENG.

TITLE:

150mm BARRIER CURB & REVERSE GUTTER

ROADWAY

REVISION No.
1

DWG.No.

C-R-105B

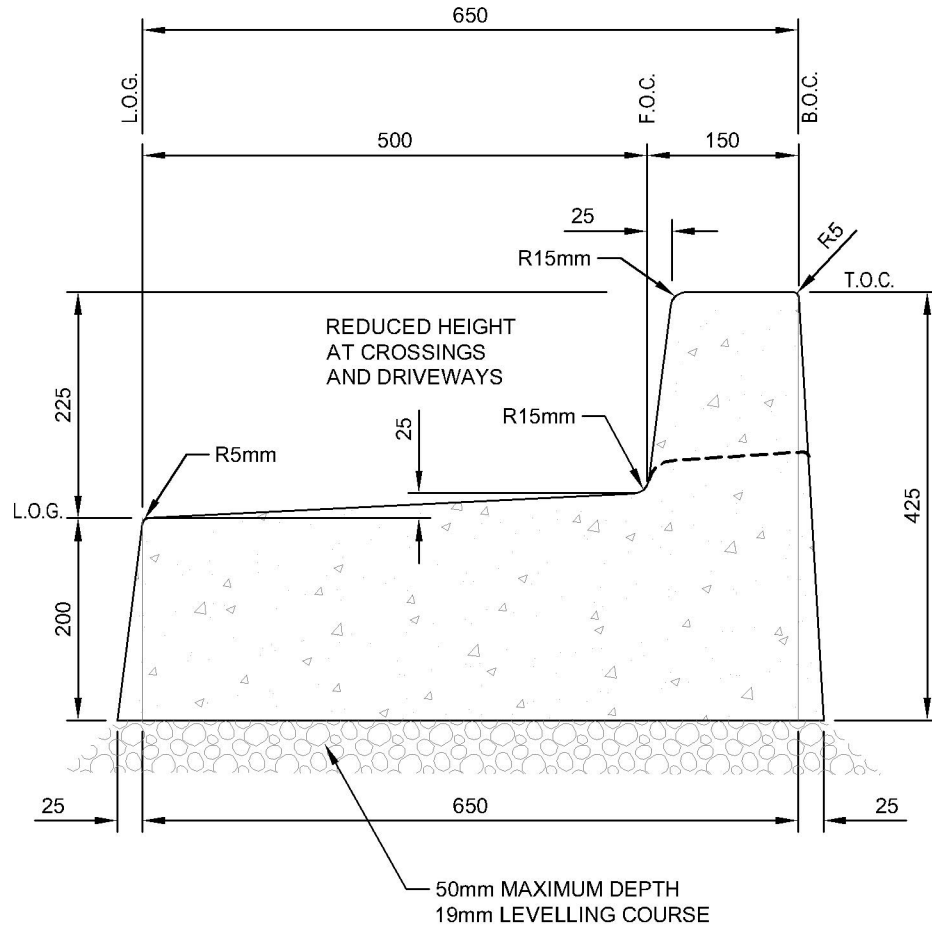

NOTES:

1. PREFERRED MATERIAL FOR BASE COURSE IS NATIVE MATERIAL.
2. CONTACT ENGINEER FOR APPROVAL OF IMPORTED GRANULAR MATERIAL IF THERE IS NO SUITABLE NATIVE MATERIAL.
3. CONTACT ENGINEER IF UNSUITABLE BASE CONDITIONS ARE ENCOUNTERED.



1:7.5

DATE DRAWN:
22/03/2021

REVISION DATE:
06/04/2022

APPROVED BY:
YK ENG.

TITLE:

200mm BARRIER CURB & REVERSE CURB

ROADWAY

REVISION No.
1

DWG.No.

C-R-105C

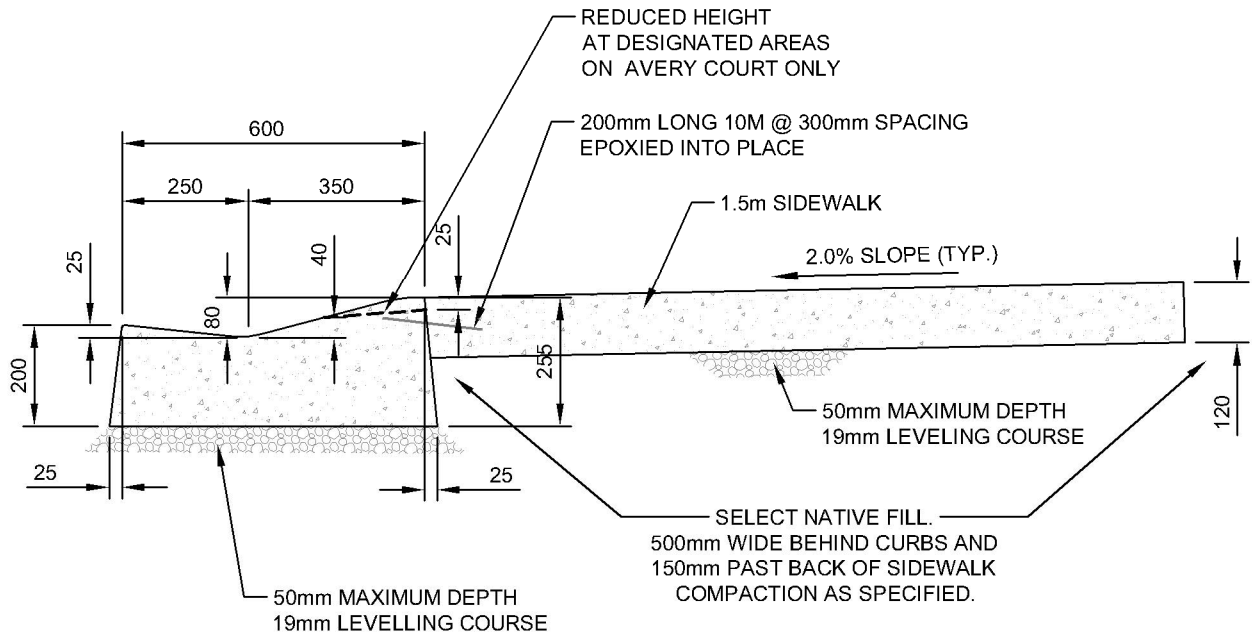

ROLLFACE CURB & GUTTER AND SIDEWALK NOTES:

1. ALL DIMENSIONS ARE IN MILLIMETERS
2. PREFERRED MATERIAL FOR BASE COURSE IS NATIVE MATERIAL
3. CONTACT ENGINEER FOR APPROVAL OF IMPORTED GRANULAR MATERIAL IF THERE IS NO SUITABLE NATIVE MATERIAL
4. CONTACT ENGINEER IF UNSUITABLE BASE CONDITIONS ARE ENCOUNTERED



1:15

DATE DRAWN:
22/03/2021

REVISION DATE:
06/04/2022

APPROVED BY:
YK ENG.

TITLE:

ROLLFACE CURB & GUTTER - CONCRETE
SIDEWALK

ROADWAY

REVISION No.
1

DWG.No.

C-R-106A

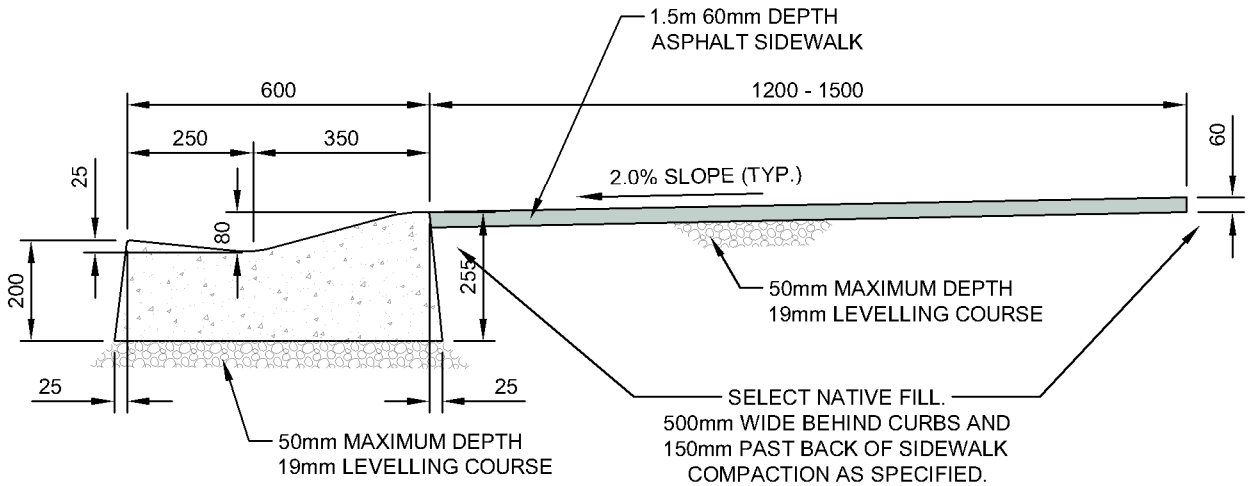

ROLLFACE CURB & GUTTER AND SIDEWALK NOTES:

1. ALL DIMENSIONS ARE IN MILLIMETERS
2. PREFERRED MATERIAL FOR BASE COURSE IS NATIVE MATERIAL
3. CONTACT ENGINEER FOR APPROVAL OF IMPORTED GRANULAR MATERIAL IF THERE IS NO SUITABLE NATIVE MATERIAL
4. CONTACT ENGINEER IF UNSUITABLE BASE CONDITIONS ARE ENCOUNTERED



AS SHOWN

DATE DRAWN:
22/03/2021

REVISION DATE:
06/04/2022

APPROVED BY:
YK ENG.

TITLE:

**ROLLFACE CURB & GUTTER - ASPHALT
SIDEWALK**

ROADWAY

REVISION No.
1

DWG.No.

C-R-106B

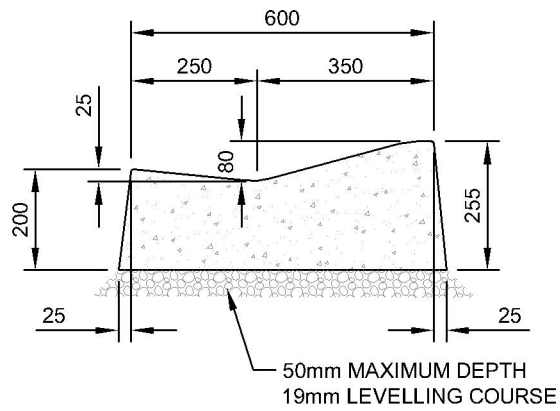

ROLLFACE CURB & GUTTER AND SIDEWALK NOTES:

1. ALL DIMENSIONS ARE IN MILLIMETERS
2. CONTACT ENGINEER FOR APPROVAL OF IMPORTED GRANULAR MATERIAL IF THERE IS NO SUITABLE NATIVE MATERIAL
3. CONTACT ENGINEER IF UNSUITABLE BASE CONDITIONS ARE ENCOUNTERED



AS SHOWN

DATE DRAWN:
22/03/2021

REVISION DATE:
06/04/2022

APPROVED BY:
YK ENG.

TITLE:

ROLLFACE CURB

ROADWAY

REVISION No.
1

DWG.No.

C-R-106C

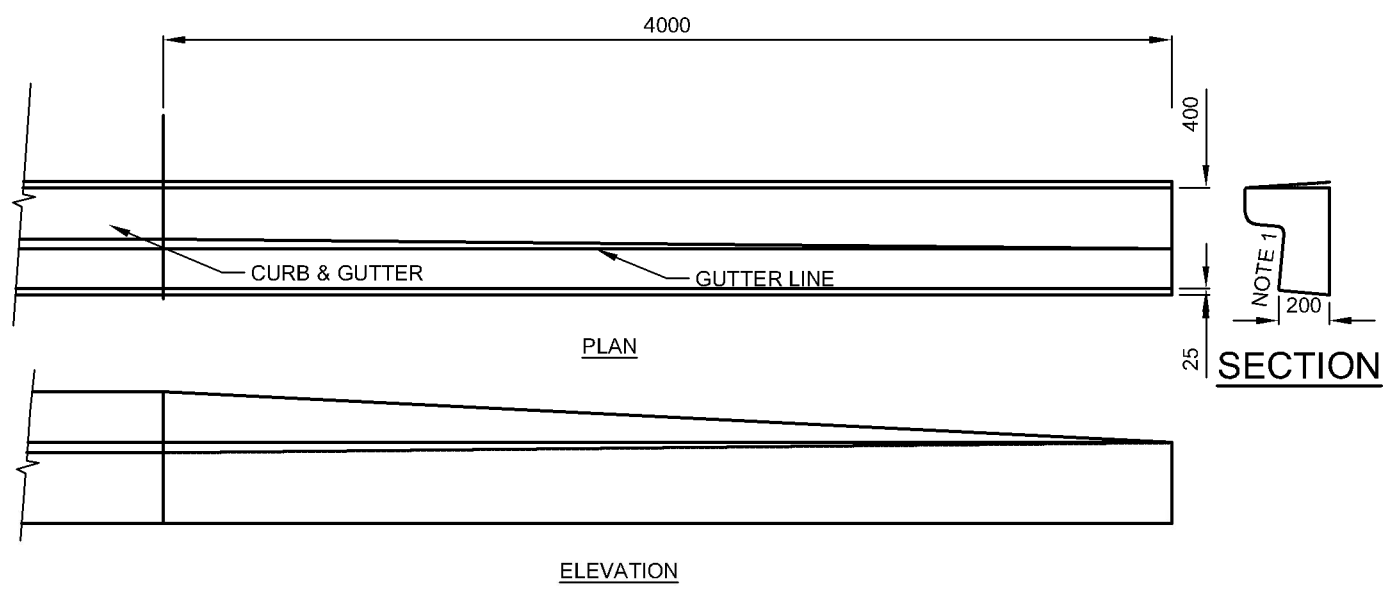
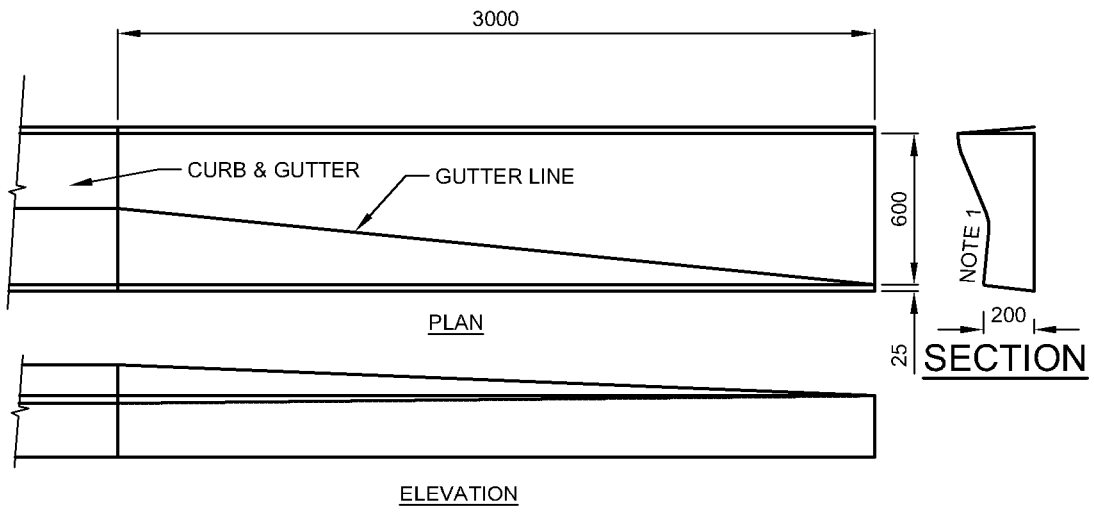

NOTE:
1. SLOPE TO MATCH EXISTING SHOULDER



1:30	
DATE DRAWN: 01/01/20	REVISION DATE: 06/04/2022
APPROVED BY: YK ENG.	

TITLE: CURB AND GUTTER TERMINATION		
ROADWAY	REVISION No. 1	DWG.No. C-R-107

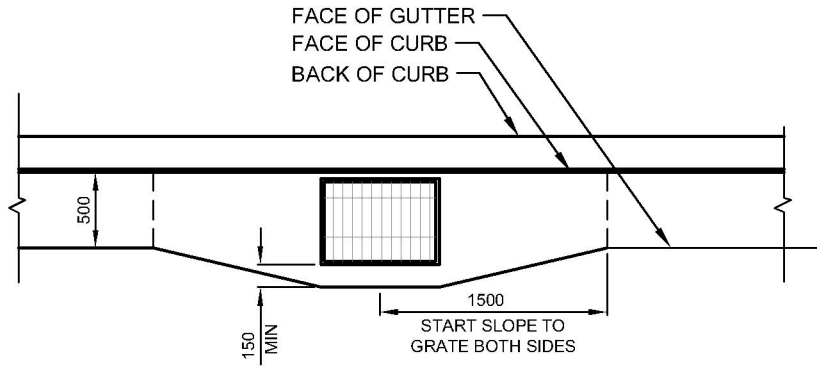

PLAN - CATCH BASIN FRAME AND COVER SET IN 200mm CURB WITH 500mm GUTTER

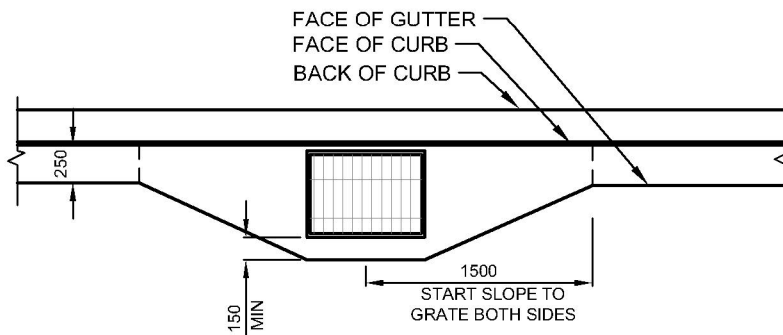

PLAN - CATCH BASIN FRAME AND COVER SET IN 150mm CURB WITH 250mm GUTTER

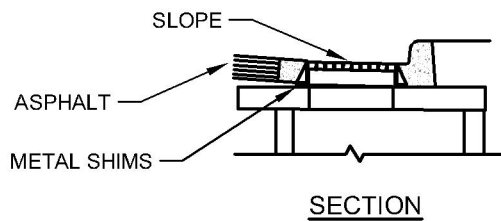
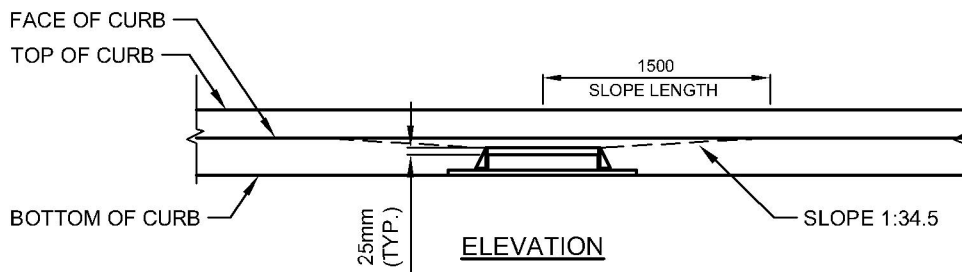

N.T.S.

DATE DRAWN:
01/01/20

REVISION DATE:
06/04/2022

APPROVED BY:
YK ENG.

TITLE:

CATCH BASIN CURB AND GUTTER TIE-IN

ROADWAY

REVISION No.
1

DWG.No.

C-R-108

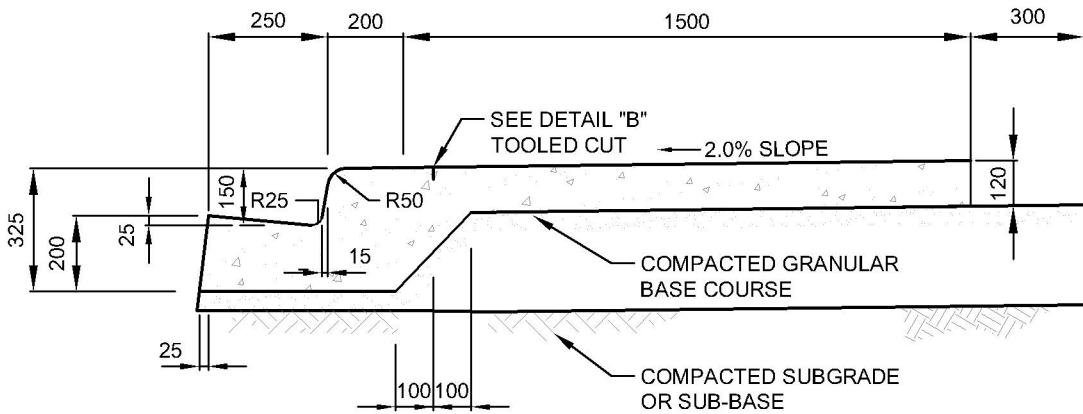

MONOLITHIC CURB, GUTTER & SIDEWALK 150mm BARRIER CURB

SCALE 1:20

NOTES:

1. ALL DIMENSIONS ARE IN MILLIMETERS.
2. FOR REVERSE GUTTER ON MONO SEE DRAWING 201
3. SHOULD A MONOLITHIC POUR NOT BE POSSIBLE 300 mm, 10M REINFORCING BARS SHALL BE INSERTED INTO THE BACK OF THE CURB AND GUTTER AT 750 mm CENTER TO CENTER. SPACING STARTING AT 375 mm FROM A CONSTRUCTION JOINT.

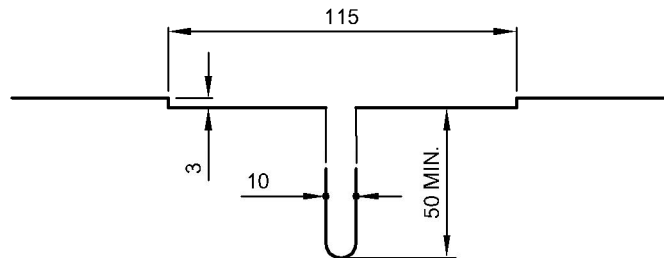

DETAIL "B"

SCALE 1:2.5



AS SHOWN

DATE DRAWN:
01/01/20

REVISION DATE:
06/04/2022

APPROVED BY:
YK ENG.

TITLE:

MONOLITHIC CURB, GUTTER & SIDEWALK
150mm BARRIER CURB

ROADWAY

REVISION No.
1

DWG.No.

C-R-109

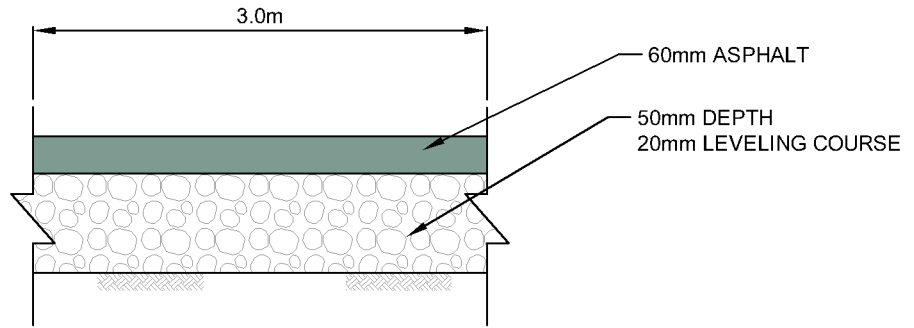

MULTI-USE PATH DETAIL
SCALE 1:50

NOTES:

1. MINIMUM WIDTH OF 3.0m MULTI -USE PATHWAYS MAY BE REQUESTED IN LIEU OF CONCRETE SIDEWALK.
2. THE GRANULAR BASE IS TO BE 150 mm WIDER THAN THE ASPHALT ON EACH SIDE.
3. MULTI-USE PATHWAYS SHALL FOLLOW SIDE-WALK STANDARDS FOR ALL DRIVEWAYS.

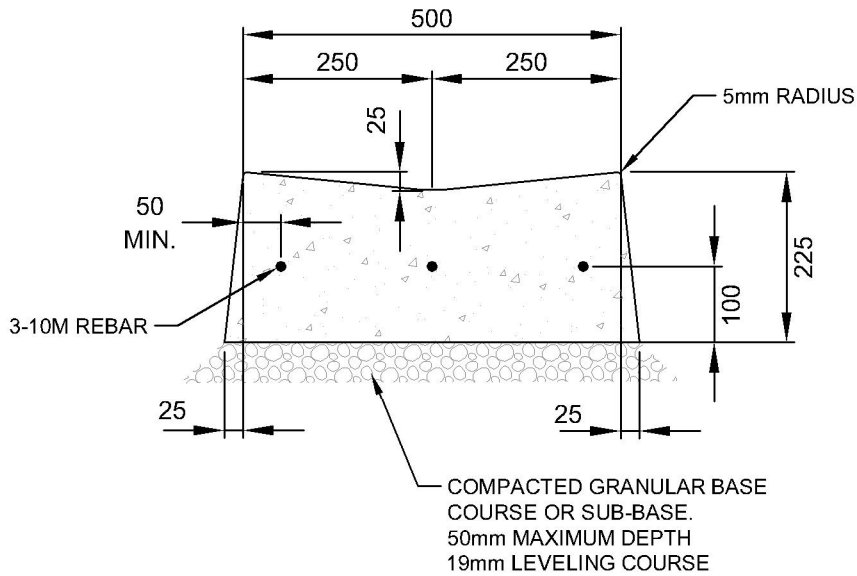

CONCRETE SWALE
SCALE 1:10

ALL DIMENSIONS ARE IN MILLIMETERS

	AS SHOWN		TITLE:		
	DATE DRAWN: 16/03/2021	REVISION DATE: 06/04/2022	MULTI-USE PATHWAY AND CONCRETE SWALES		
	APPROVED BY: YK ENG.		ROADWAY	REVISION No. 1	DWG.No. C-R-110A

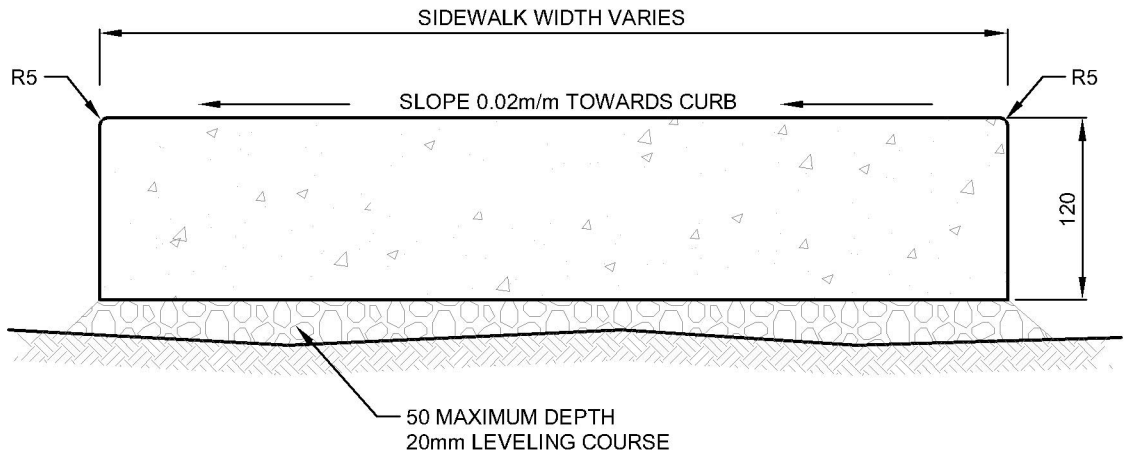

NOTE:

- ELEVATION OF FRONT OF WALK TO BE SET SUCH THAT A MINIMUM SLOPE OF 0.02 m/m IS MAINTAINED ACROSS BOULEVARD BETWEEN FRONT OF WALK AND TOP OF CURB.

TYPICAL SECTION

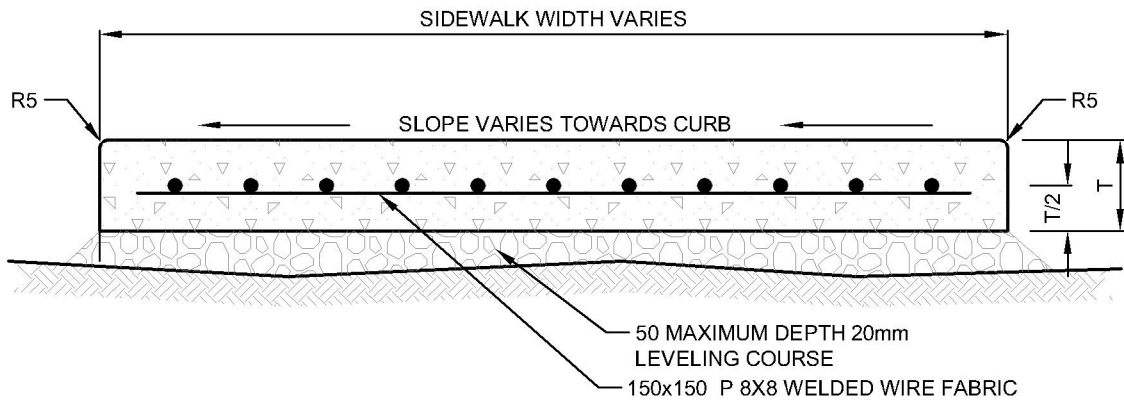

NOTES:

1. THICKNESS "T" = 150 FOR PRIVATE CROSSINGS (NO WIRE REQUIRED).
2. THICKNESS "T" = 175 FOR LANE AND COMMERCIAL CROSSINGS (WIRE REQUIRED).
3. 0.02 m/m MINIMUM CROSS SLOPE FOR ALL CROSSINGS.
4. WHERE SLOPE BETWEEN TOP OF DEPRESSED CURB CROSSING AND FRONT OF WALK WOULD EXCEED 0.08 m/m FOR PRIVATE (0.04 m/m FOR LANE AND COMMERCIAL CROSSINGS), SIDEWALK CROSSINGS SHALL BE DEPRESSED SUCH THAT MAXIMUM SLOPE ACROSS BOTH BOULEVARD AND SIDEWALK DOES NOT EXCEED 0.08 m/m (0.04 m/m FOR LANE AND COMMERCIAL CROSSINGS).
5. PREFERRED MATERIAL FOR BASE COURSE IS NATIVE MATERIAL
6. CONTACT ENGINEER FOR APPROVAL OF IMPORTED GRANULAR MATERIAL IF NO SUITABLE NATIVE MATERIAL.
7. CONTACT ENGINEER IF UNSUITABLE BASE CONDITIONS ARE ENCOUNTERED.

SEPARATE SIDEWALK - SECTION AT CROSSING



	1:5	TITLE:		
	DATE DRAWN: 01/01/20	REVISION DATE: 06/04/2022	SEPARATE SIDEWALK	
	APPROVED BY: YK ENG.		ROADWAY	REVISION No. 1
				DWG.No. C-R-110

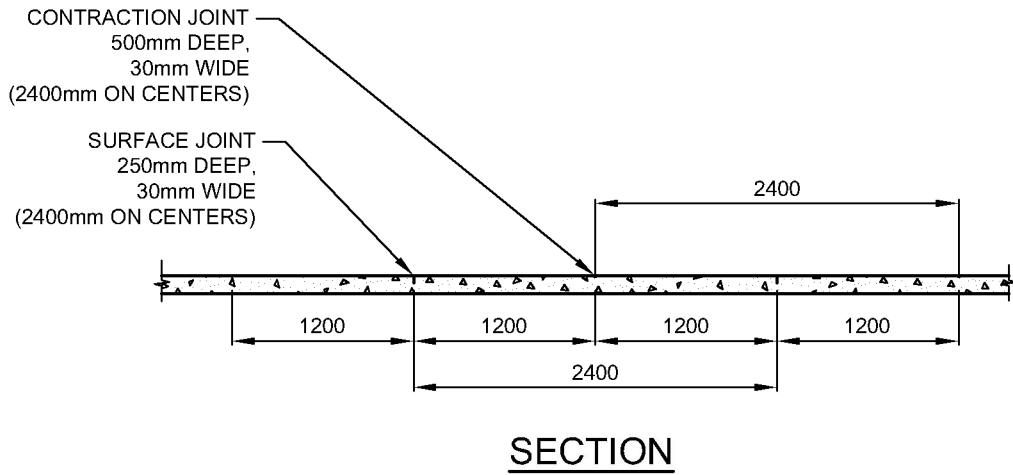
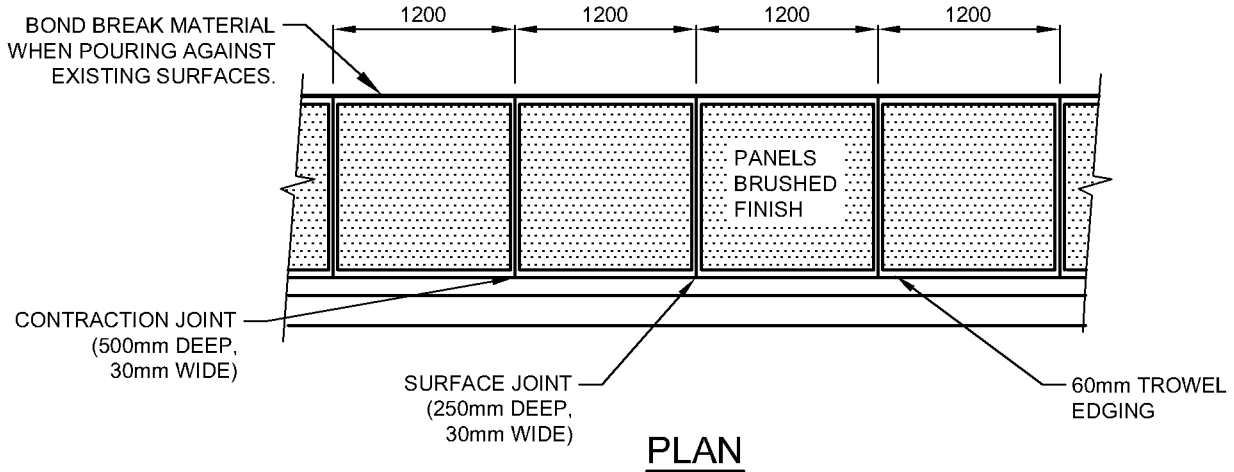

1:50	
DATE DRAWN: 01/01/20	REVISION DATE: 06/04/2022
APPROVED BY: YK ENG.	

TITLE: SIDEWALK JOINT AND FINISHING		
ROADWAY	REVISION No. 1	DWG.No. C-R-111

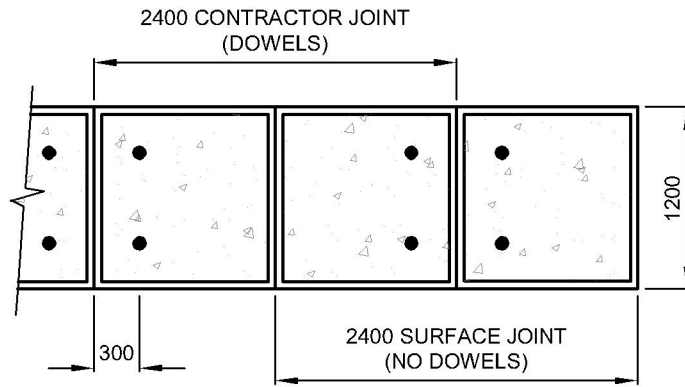

PLAN
SCALE 1:50

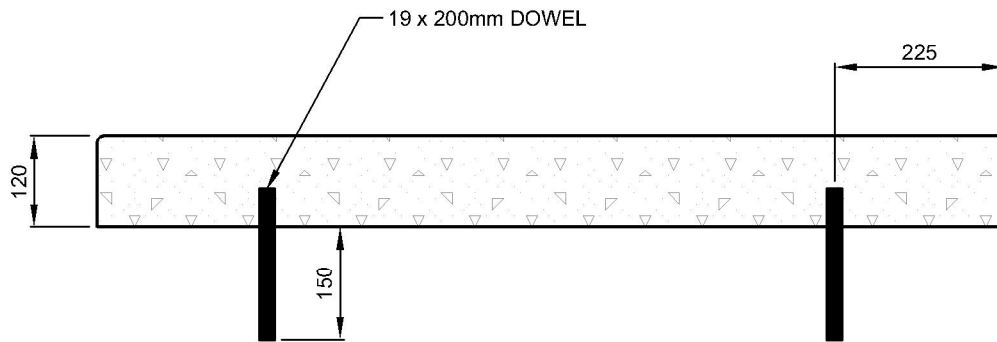

SECTION
SCALE 1:10



AS SHOWN

DATE DRAWN:
01/01/20

REVISION DATE:
06/04/2022

APPROVED BY:
YK ENG.

TITLE:

PIN WALK DETAIL FOR LANE

ROADWAY

REVISION No.
1

DWG.No.

C-R-112

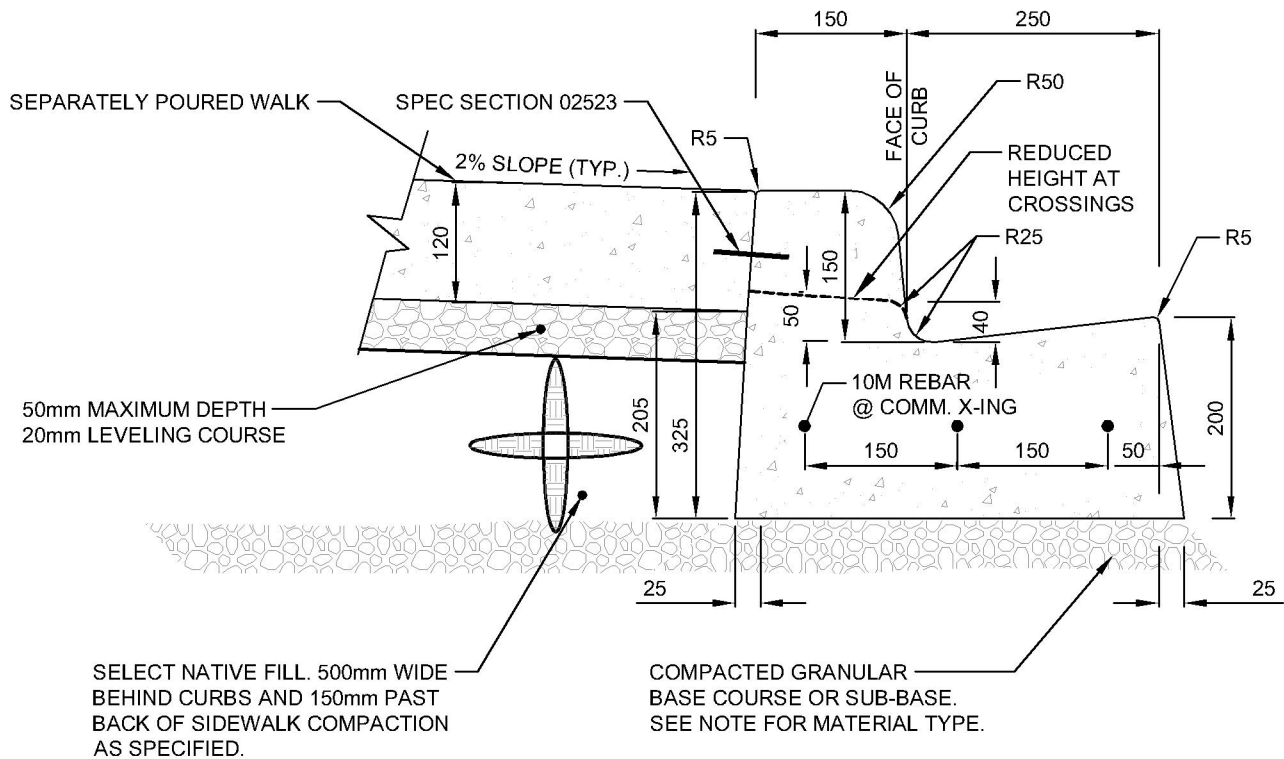

NOTES:

1. REDUCE CURB HEIGHT AT ALL CROSSINGS AND DRIVEWAYS.
2. 3-10M REBAR AT ALL LANE AND COMMERCIAL CROSSINGS.
3. WHERE PLACED OVER DISTURBED SOIL, USE GRANULAR MATERIAL COMPACTED TO PROJECT SPECIFICATIONS.
4. PREFERRED MATERIAL FOR BASE COURSE IS NATIVE MATERIAL.
5. CONTACT ENGINEER FOR APPROVAL OF IMPORTED GRANULAR MATERIAL IF THERE IS NO SUITABLE NATIVE MATERIAL.
6. CONTACT ENGINEER IF UNSUITABLE BASE CONDITIONS ARE ENCOUNTERED.



1:7.5

DATE DRAWN:
01/01/20

REVISION DATE:
06/04/2022

APPROVED BY:
YK ENG.

TITLE:

WALK POURED SEPERATE FROM
150mm BARRIER CURB AND GUTTER

ROADWAY

REVISION No.
1

DWG.No.

C-R-113

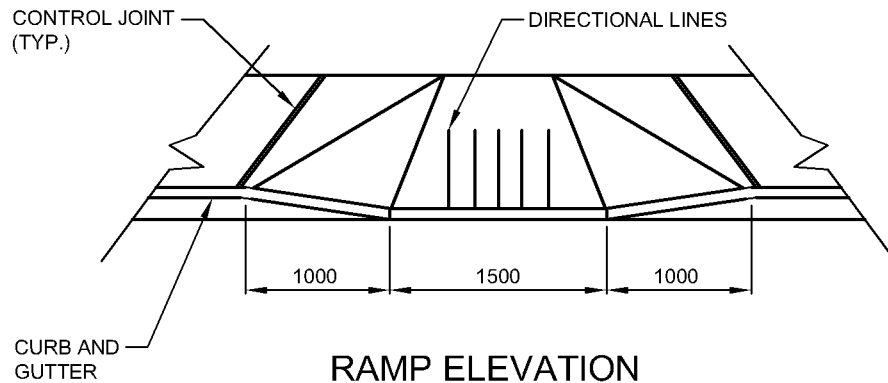

RAMP ELEVATION

SCALE 1:50

NOTES:

1. ALL DIMENSIONS IN MILLIMETRES UNLESS OTHERWISE NOTED.
2. TOOLED GROOVES 5 WIDEx10 DEEP, BROOM FINISH GROOVE SPACING 150 O.C. ADJACENT TO CURB.
3. WHERE RAMP TO BE USED AS A TRANSITION, USE THE CENTER OF THE 1500 RAMP AS THE CENTER OF THE TRANSITION.
4. CURBS AND RAMPS TO BE POURED MONOLITHICALLY.
5. IT MAY BE NECESSARY TO BUILD RAMPS WIDER AT HIGH VOLUME PEDESTRIAN TRAFFIC LOCATIONS.
6. WHEN THE CURB RETURN RADIUS IS LESS THAN 4.0m TWO RAMPS ARE REQUIRED.
7. MATCH ASPHALT SURFACE TO GUTTER LIP WITHIN 3mm PLUS OR MINUS.

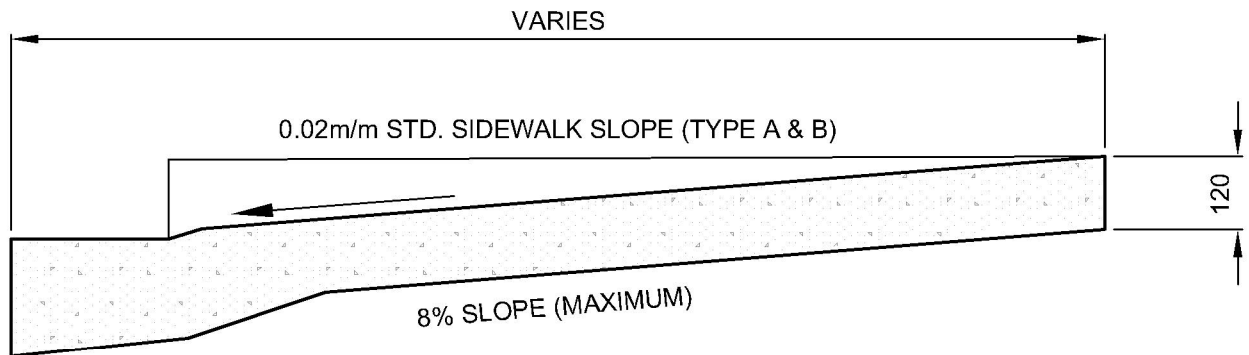

TYPICAL CROSS SECTION

SCALE 1:15



AS SHOWN

DATE DRAWN:
01/01/20

REVISION DATE:
06/04/2022

APPROVED BY:
YK ENG.

TITLE:

PARA-RAMP

ROADWAY

REVISION No.
1

DWG.No.

C-R-114

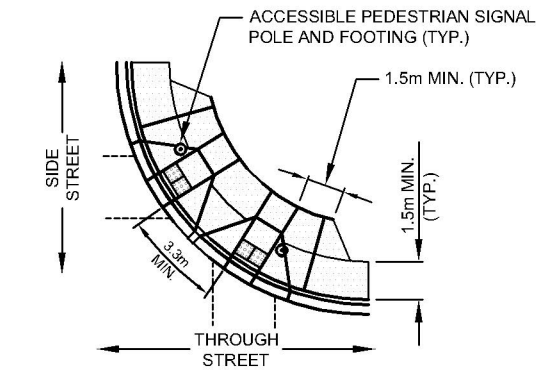

DOUBLE RAMP WITHOUT BOULEVARD

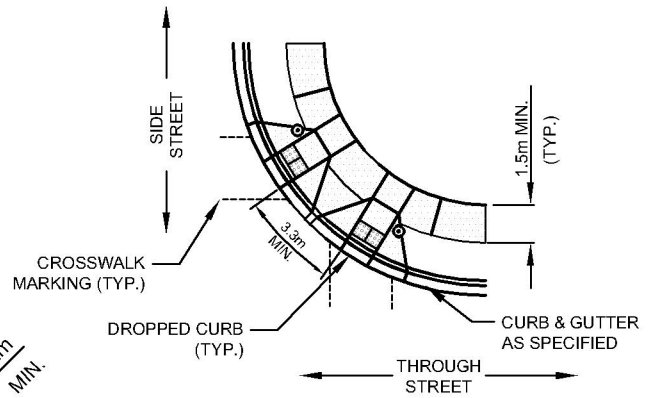

DOUBLE RAMP WITH BOULEVARD

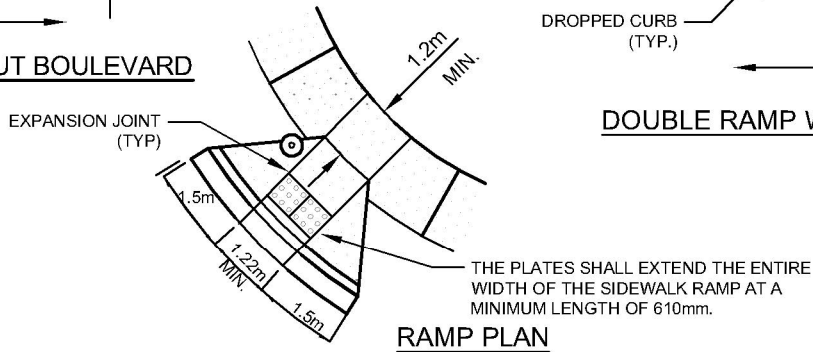

RAMP PLAN

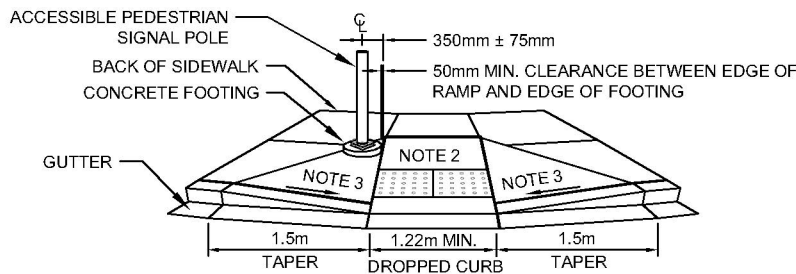

RAMP ELEVATION

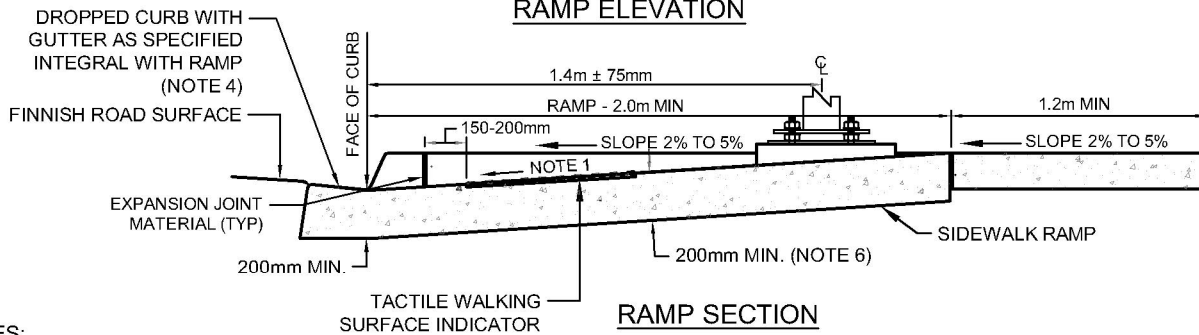

RAMP SECTION

NOTES:

1. SLOPE OF RAMPS SHALL NOT EXCEED 8%.
 2. CROSS SLOPE OF RAMPS SHALL NOT EXCEED 2% IN EITHER DIRECTION.
 3. CROSS SLOPE OF FLARED SIDE OF RAMP SHALL NOT EXCEED 8%.
 4. DROPPED CURB AT RAMP SHALL BE MODIFIED TO ELIMINATE 30mm STEP AT GUTTER.
 5. ACCESSIBLE PEDESTRIAN SIGNAL TO HAVE TACTILE ARROW THAT ALIGNS WITH THE DIRECTION OF CROSSWALK..
 6. MINIMUM THICKNESS AT RAMP IS 200mm. MINIMUM THICKNESS OF SIDEWALK AND FLARED SIDES ADJACENT TO RAMP IS 150mm.
- A. WHERE ONLY ONE CROSSWALK IS PRESENT AT AN INTERSECTION, ONLY ONE CURB RAMP IS REQUIRED.
- A. ALL DIMENSIONS ARE IN MILLIMETRES UNLESS OTHERWISE SHOWN.



N.T.S

DATE DRAWN:
03/25/2021

REVISION DATE:
06/04/2022

APPROVED BY:
YK ENG.

TITLE:

PARA-RAMP AT SIGNALIZED INTERSECTION

ROADWAY

REVISION No.
1

DWG.No.

C-R-114A

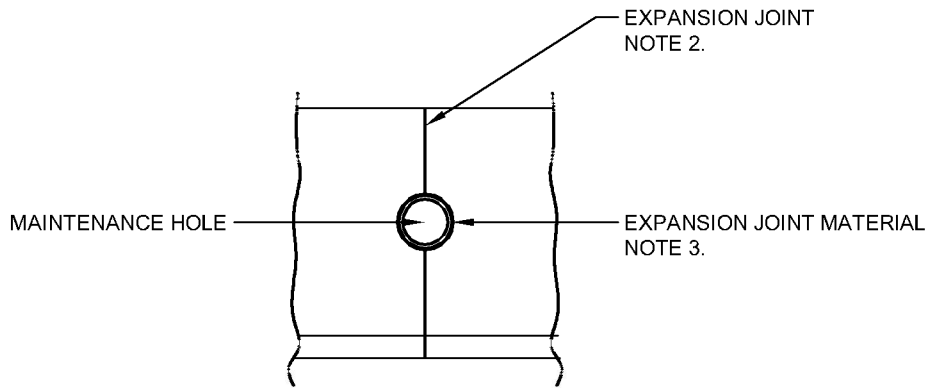

UTILITY APPURTENANCE

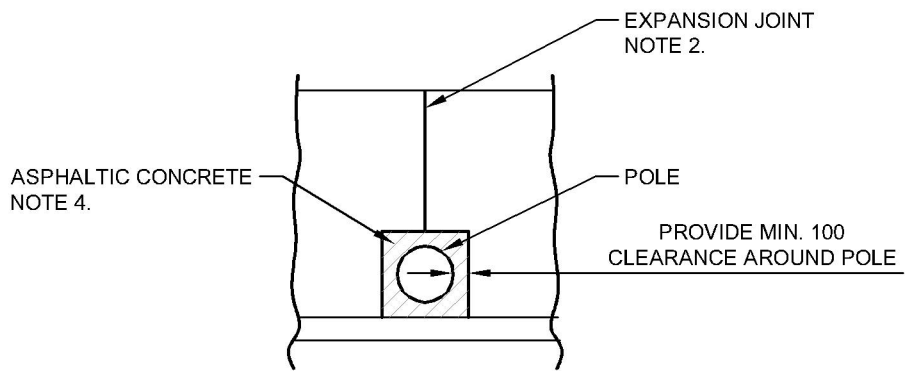

UTILITY POLE

NOTES:

1. ADJUST JOINTS TO COINCIDE WITH CENTER OF UTILITY, WITH MIN. SLAB LENGTH OF 1m.
2. EXPANSION JOINT MATERIAL SHALL BE PLACED AROUND MAINTENANCE HOLES FLUSH WITH CONCRETE SURFACE.
3. FOR PORTLAND CEMENT CONCRETE ALTERNATIVE USE EXPANSION JOINT MATERIAL AROUND BOXOUT.



1:50

DATE DRAWN:
01/01/20

REVISION DATE:
06/04/2022

APPROVED BY:
YK ENG.

TITLE:

UTILITY ISOLATION IN SIDEWALKS

ROADWAY

REVISION No.
1

DWG.No.

C-R-115

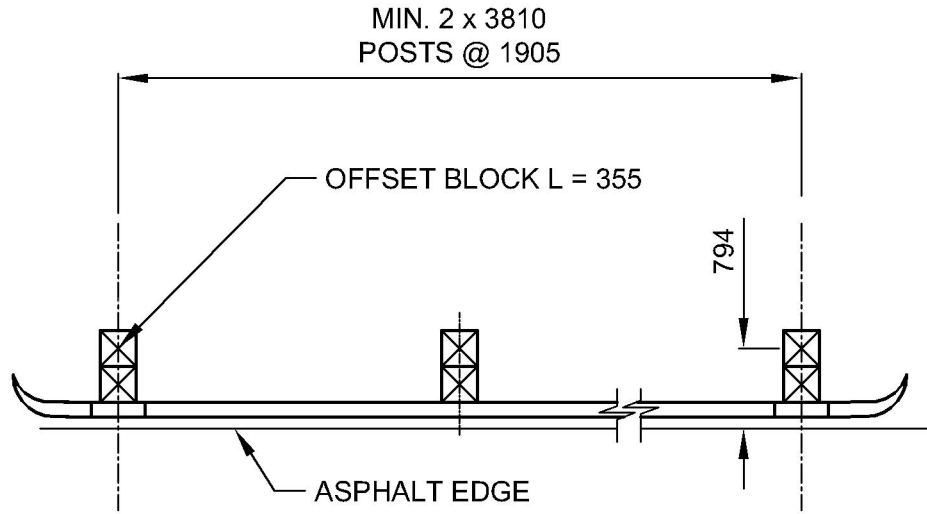

PLAN

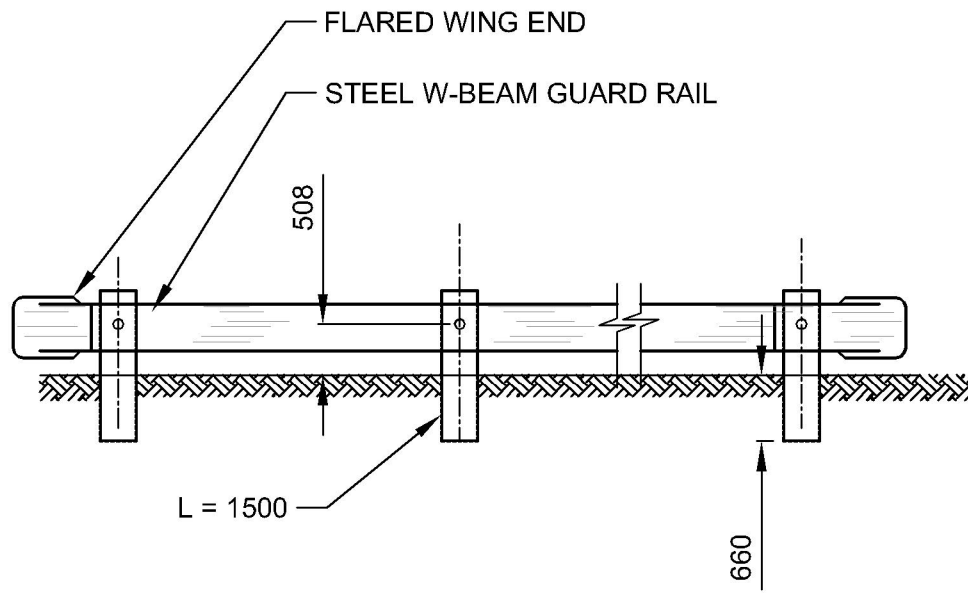

ELEVATION



13.333315

TITLE:

GUARD RAIL PLAN AND ELEVATION

DATE DRAWN:
01/01/20

REVISION DATE:
06/04/2022

APPROVED BY:
YK ENG.

ROADWAY

REVISION No.
1

DWG.No.

C-R-116

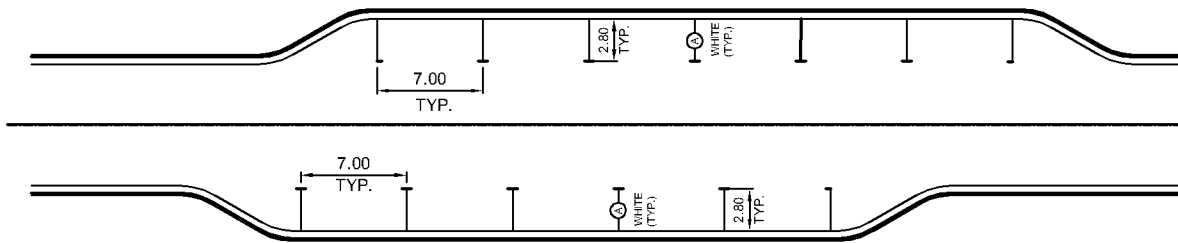

TYPICAL PARALLEL STREET PARKING



1:500

DATE DRAWN:
30/03/2021

REVISION DATE:
06/04/2022

APPROVED BY:
YK ENG.

TITLE:

TYPICAL PARALLEL STREET PARKING

ROADWAY

REVISION No.
1

DWG.No.

C-R-117

Figure 47 – Typical Markings for Parallel Parking

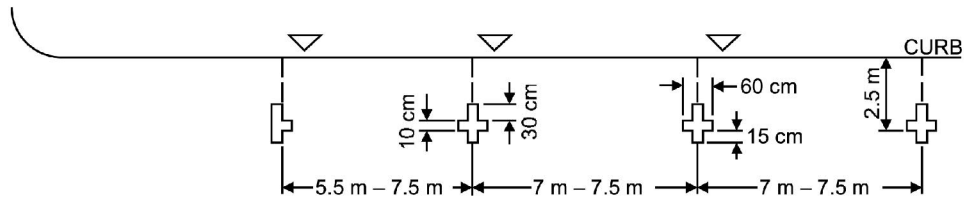

SINGLE METERS

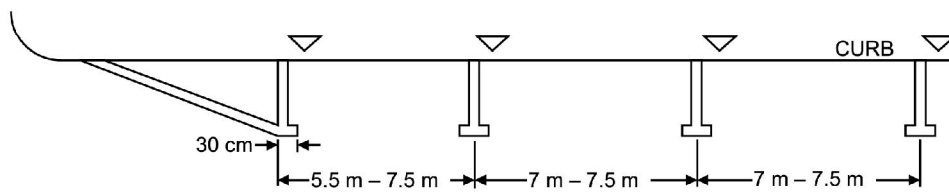

SINGLE METERS

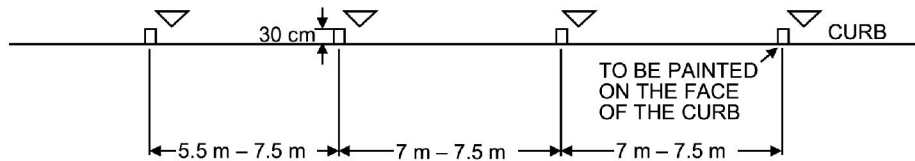

SINGLE METERS

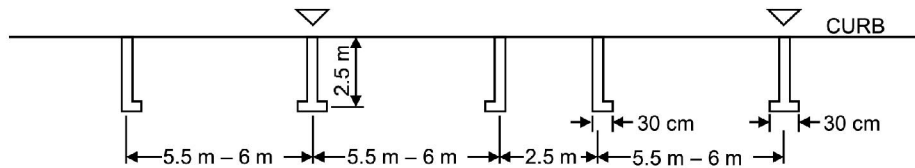

TWIN METERS



N.T.S.

TITLE:

PARKING MARKINGS (REFERENCE)

DATE DRAWN:

30/03/2021

REVISION DATE:

06/04/2022

APPROVED BY:

YK ENG.

ROADWAY

REVISION No.



1

DWG.No.

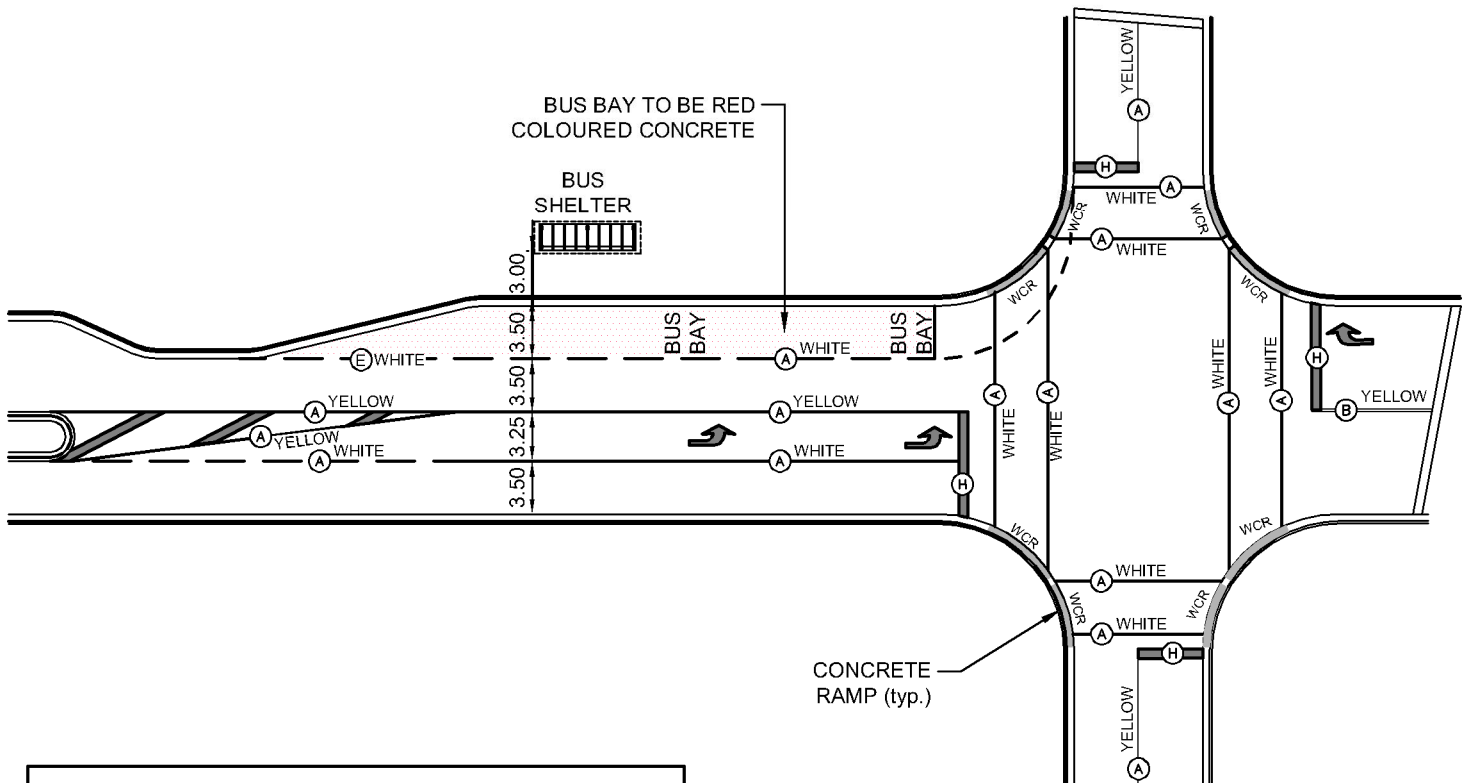
C-R-117A

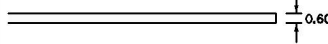

PAVEMENT MARKINGS LEGEND

	DIMENSIONS (m)	USE
(A)	 0.10	EDGE LINES (WHITE OR YELLOW), DIRECTIONAL DIVIDING LINES (YELLOW) LANE LINES PROHIBITING LANE CHANGES (WHITE)
(B)	 0.10	DIRECTIONAL DIVIDING LINES (YELLOW)
(E)	 0.10	GUIDING LINES (E.G. INTERSECTION MOVEMENTS) (WHITE)
(H)	 0.60	INTERSECTION STOP LINES (WHITE)



1:500

DATE DRAWN: 03/30/2021 REVISION DATE: 06/04/2022

APPROVED BY: YK ENG.

TITLE: **BUS PULLOUT LAYOUT**

ROADWAY REVISION No. 1 DWG.No. C-R-118

Figure 35 – Typical Markings for Bus Bays

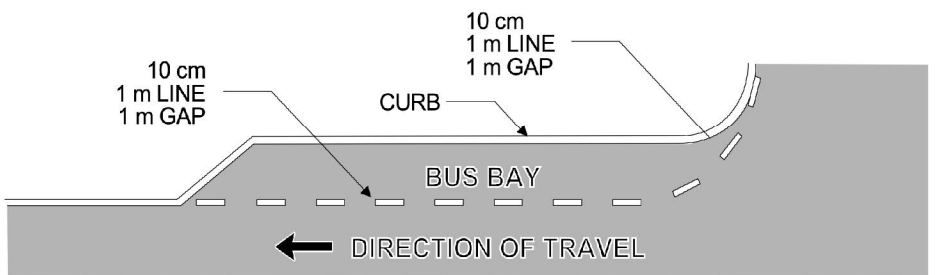
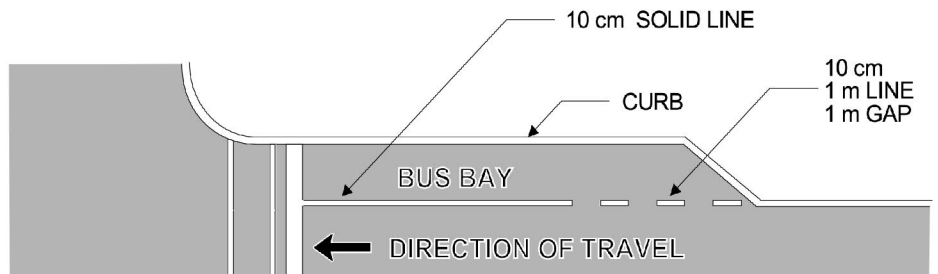
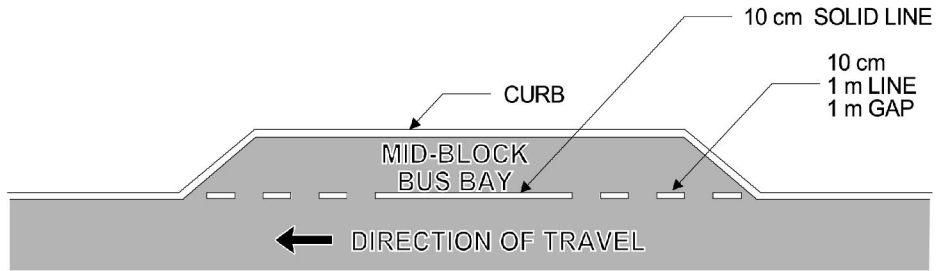

N.T.S.

TITLE:

BUS PULLOUT LAYOUT (REFERENCE)

DATE DRAWN:
01/01/20

REVISION DATE:
06/04/2022

APPROVED BY:
D.MCMILLAN

ROADWAY

REVISION No.
1

DWG.No.

C-R-118A

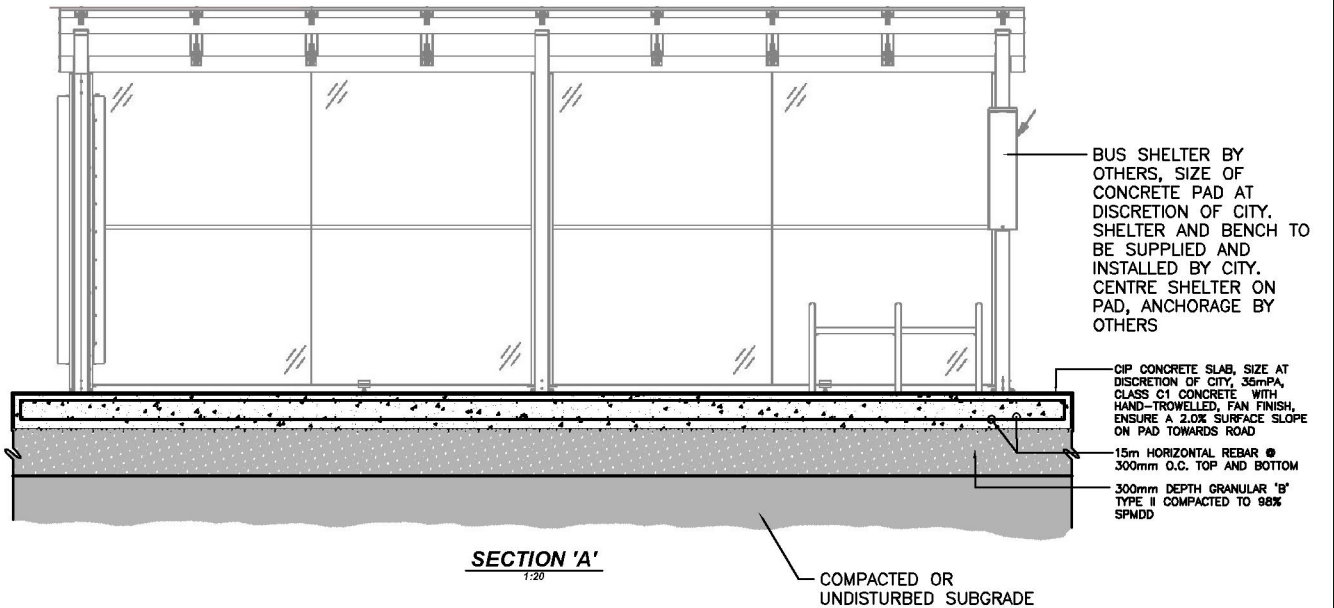
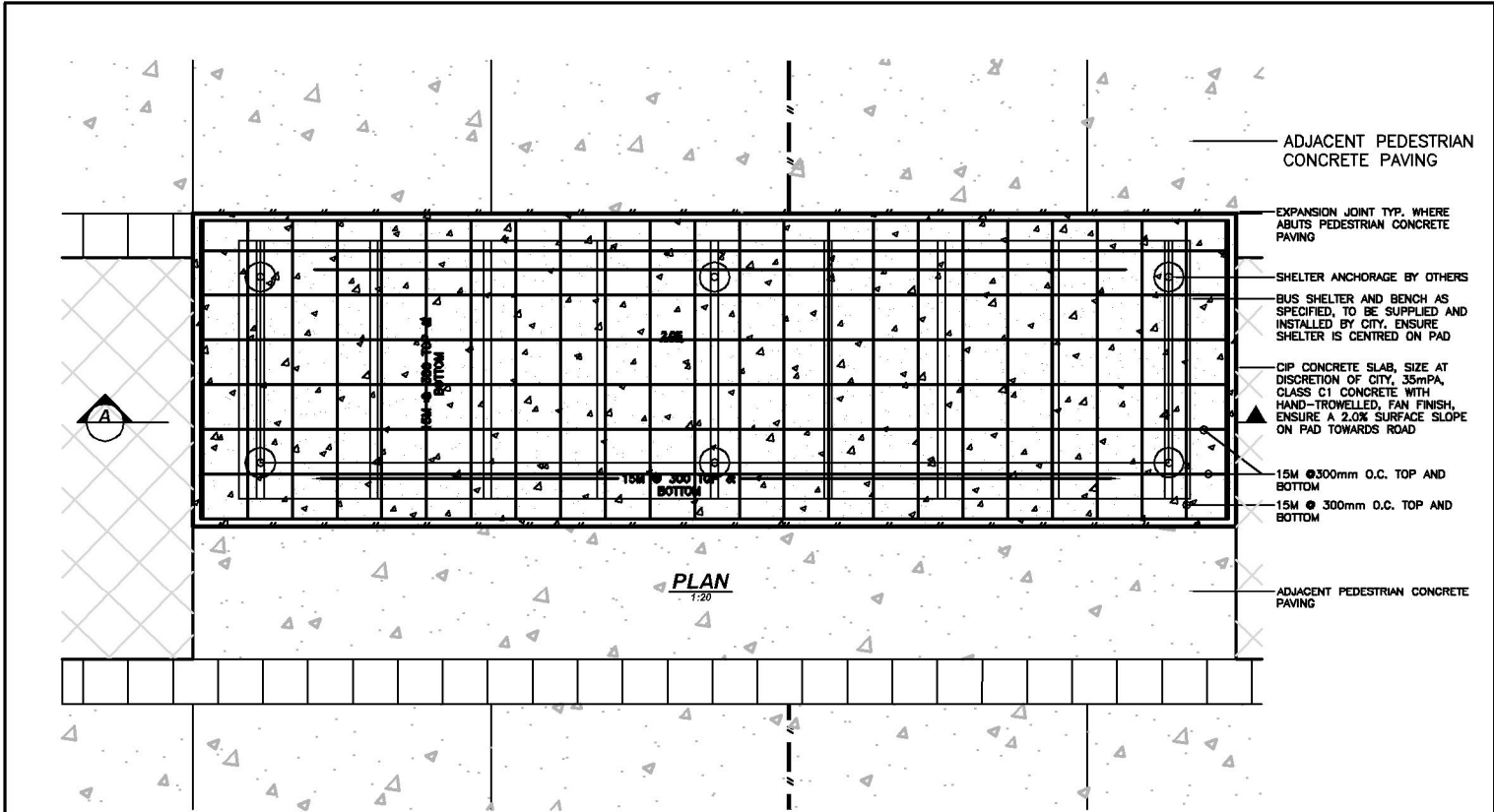

N.T.S.	
DATE DRAWN: 30/03/2021	REVISION DATE: 06/04/2022
APPROVED BY: YK ENG.	

TITLE: BUS SHELTER (REFERENCE)	REVISION No. 1	DWG.No. C-R-118B
ROADWAY		

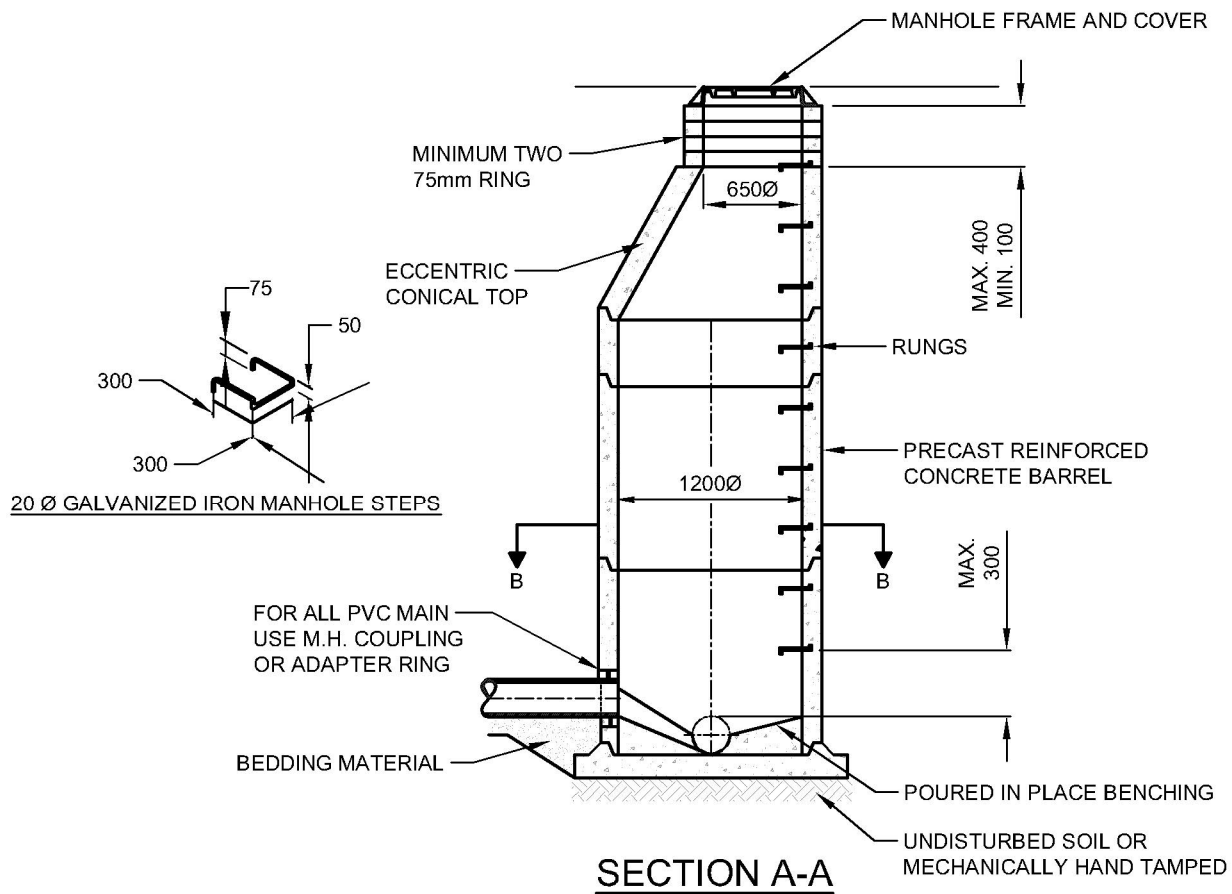

NOTES:

1. PRECAST RINGS, CONES AND BARRELS TO MEET CURRENT A.S.T.M. C478 STANDARDS.
2. POURED IN PLACE CONCRETE TO BE 25 M Pa AT 28 DAYS.
3. FOR MANHOLES OVER 4.8m IN DEPTH, THE BASE SHALL BE REINFORCED WITH 13 Ø REBAR AT 250 CENTER EACH WAY.
4. SAFETY STEPS TO BE SPACED AT 400 MAX. DISTANCE.
5. ALL JOINTS TO BE SET IN MORTAR.
6. CHANNELING AND BENCHING TO BE FINISHED TO TROWEL SMOOTHNESS.
7. MINIMUM 150 CONCRETE BASE TO BE CONSTRUCTED ON COMPACTED GRANULAR MATERIAL OR UNDISTURBED NATIVE MATERIAL.
8. COMPACT BACKFILL AROUND MANHOLES TO A MINIMUM OF 97% STANDARD PROCTOR DENSITY.

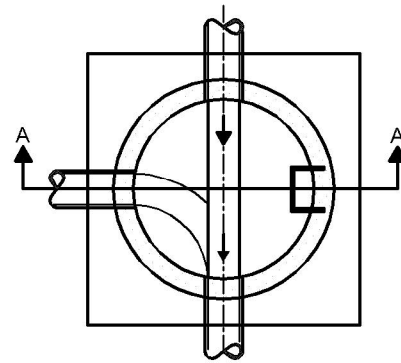

SECTION B-B



1:50

TITLE:

PRECAST MANHOLE

DATE DRAWN:

01/01/20

REVISION DATE:

06/04/2022

APPROVED BY:

YK ENG.

SANITARY

REVISION No.

1

DWG.No.

C-S-100

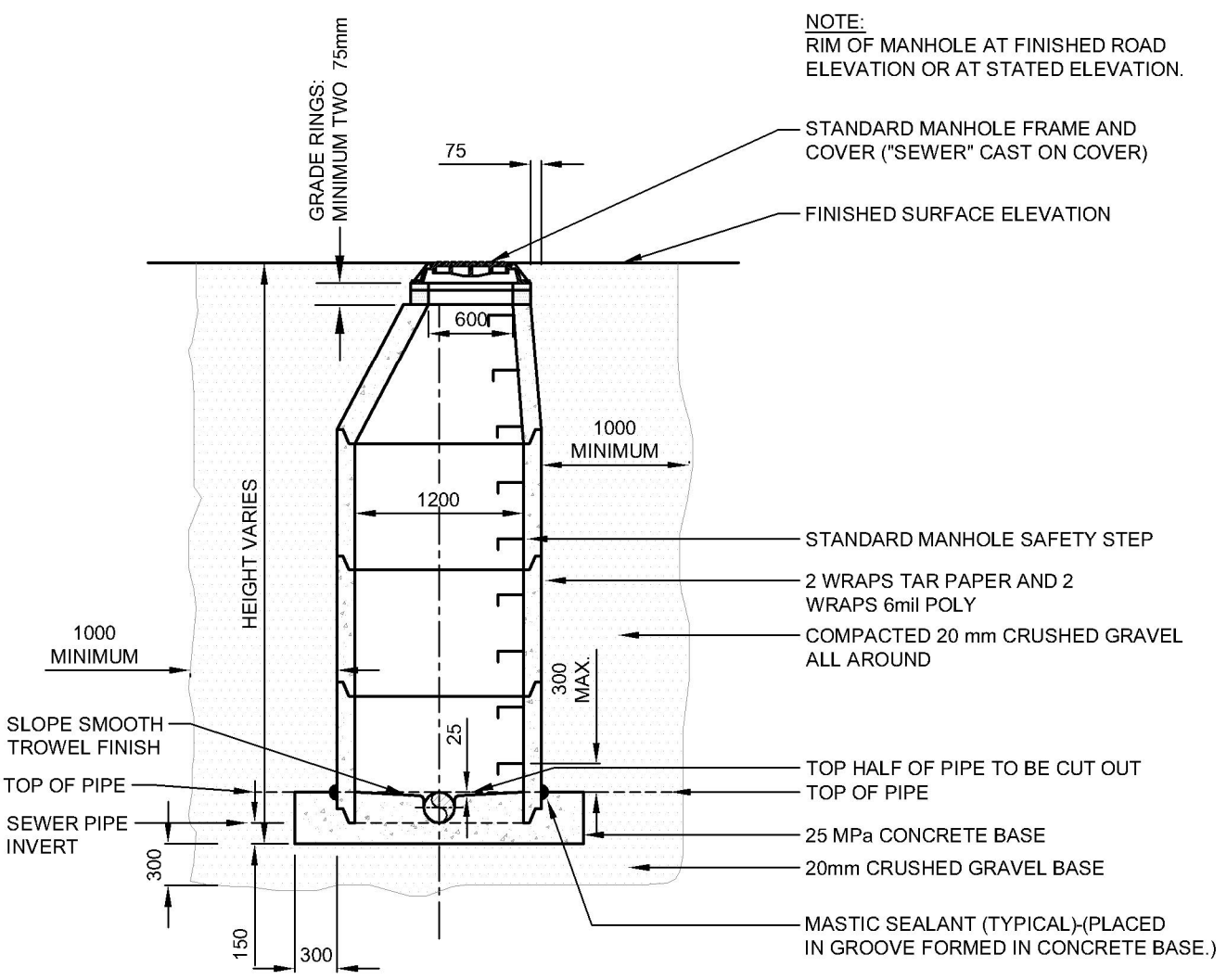

NOTE:
FOR INSULATION DETAIL SEE TYPICAL INSULATED MANHOLE DETAIL



1:50	
DATE DRAWN: 01/01/20	REVISION DATE: 06/04/2022
APPROVED BY: YK ENG.	

TITLE: TYPICAL PRECAST MANHOLE INSTALLATION		
SANITARY	REVISION No. 1	DWG.No. C-S-101

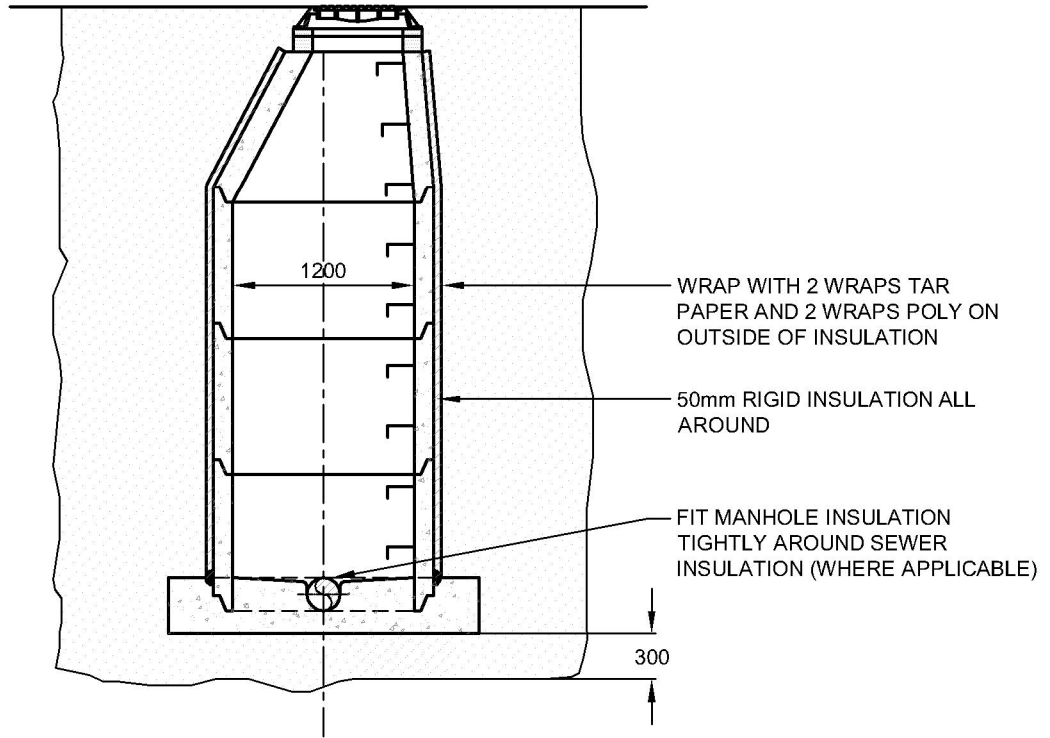

NOTE:
FOR TYPICAL MANHOLE DETAILS SEE TYPICAL PRECAST MANHOLE DETAIL



1:50

DATE DRAWN:
01/01/20

REVISION DATE:
06/04/2022

APPROVED BY:
YK ENG.

TITLE:

TYPICAL INSULATED MANHOLE

SANITARY

REVISION No.
1

DWG.No.

C-S-102

ALL ROBAR COUPLINGS c/w FACTORY APPLIED TWO PART EPOXY COATING TO AWWA C210-84, COUPLING NUTS AND BOLTS TO BE STAINLESS STEEL.

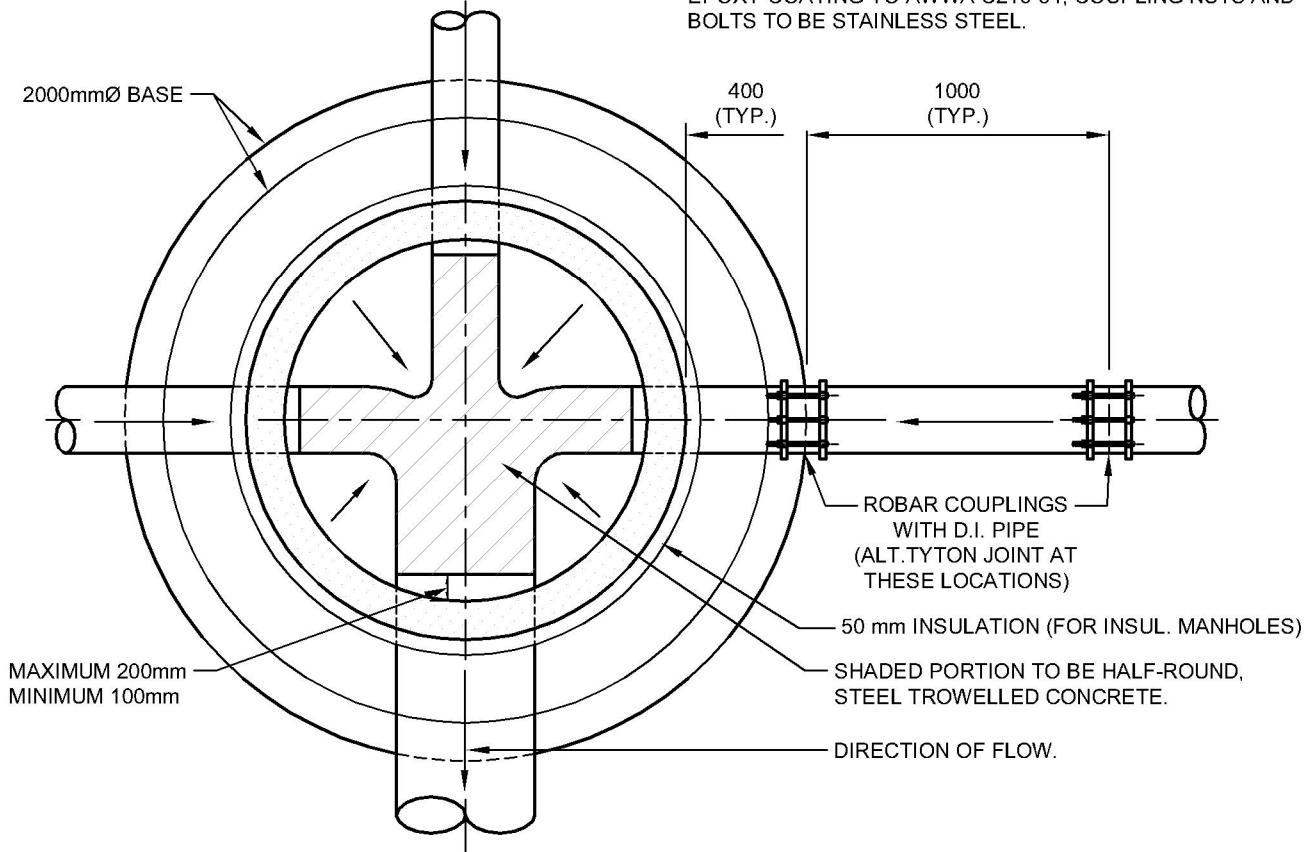

ALTERNATIVE:
WHERE ONE PIPE ONLY PASSES THROUGH MANHOLE TOP HALF OF PIPE MAY BE REMOVED, LOWER HALF TO FORM BENCHING.



1:25

DATE DRAWN:
01/01/20

REVISION DATE:
06/04/2022

APPROVED BY:
YK ENG.

TITLE:

STANDARD SHAPING OF MANHOLE BOTTOMS

SANITARY

REVISION No.
1

DWG.No.

C-S-103

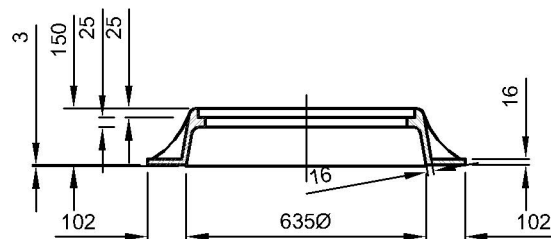
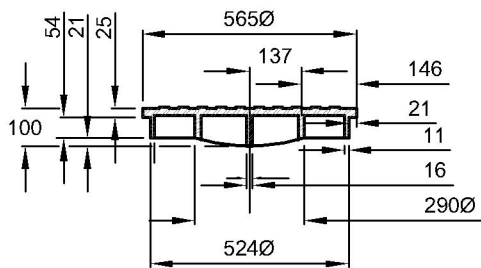
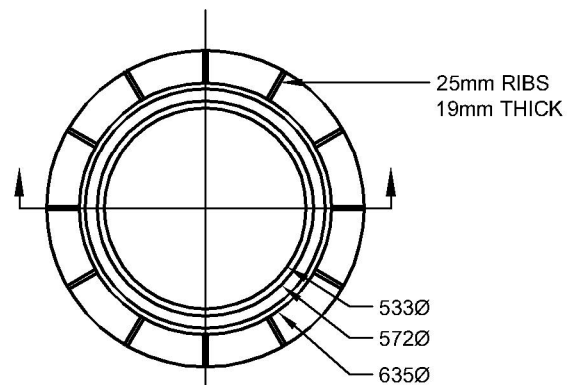
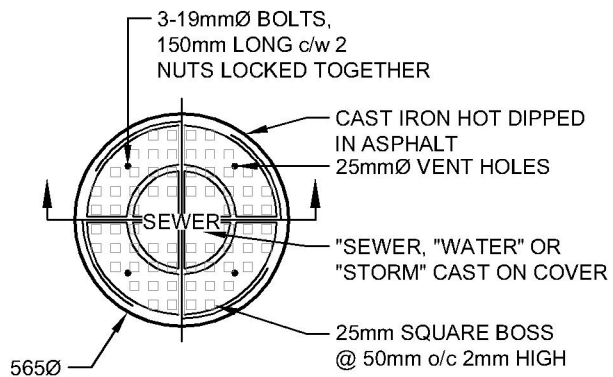

USE ALSO FOR STORM SEWER MANHOLES, WATER
AND HYDRANT VAULTS COVER LABELED "STORM"
OR "WATER" RESPECTIVELY



1:20

DATE DRAWN:
01/01/20

REVISION DATE:
06/04/2022

APPROVED BY:
YK ENG.

TITLE:

STANDARD MANHOLE FRAME AND COVER F-39

SANITARY

REVISION No.
1

DWG.No.

C-S-104

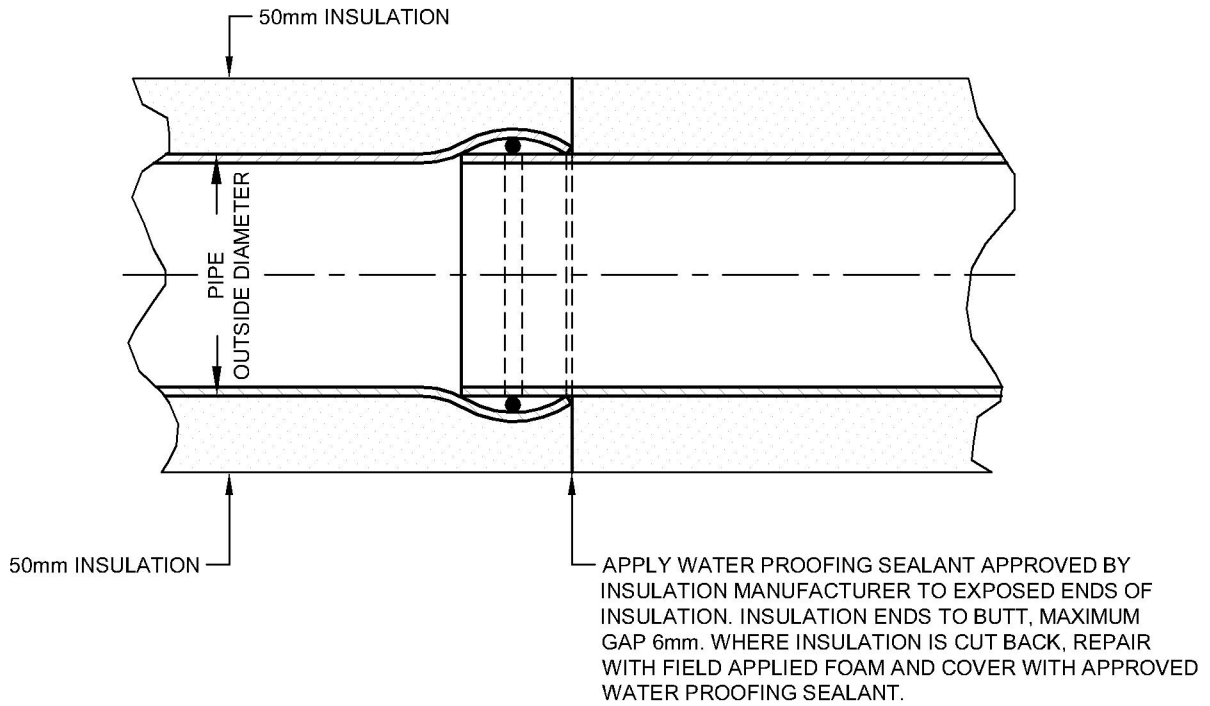

1:5

DATE DRAWN:
01/01/20

REVISION DATE:
06/04/2022

APPROVED BY:
YK ENG.

TITLE:

INSULATED SANITARY SEWER-BELL AND
SPIGOT JOINT

SANITARY

REVISION No.
1

DWG.No.

C-S-105

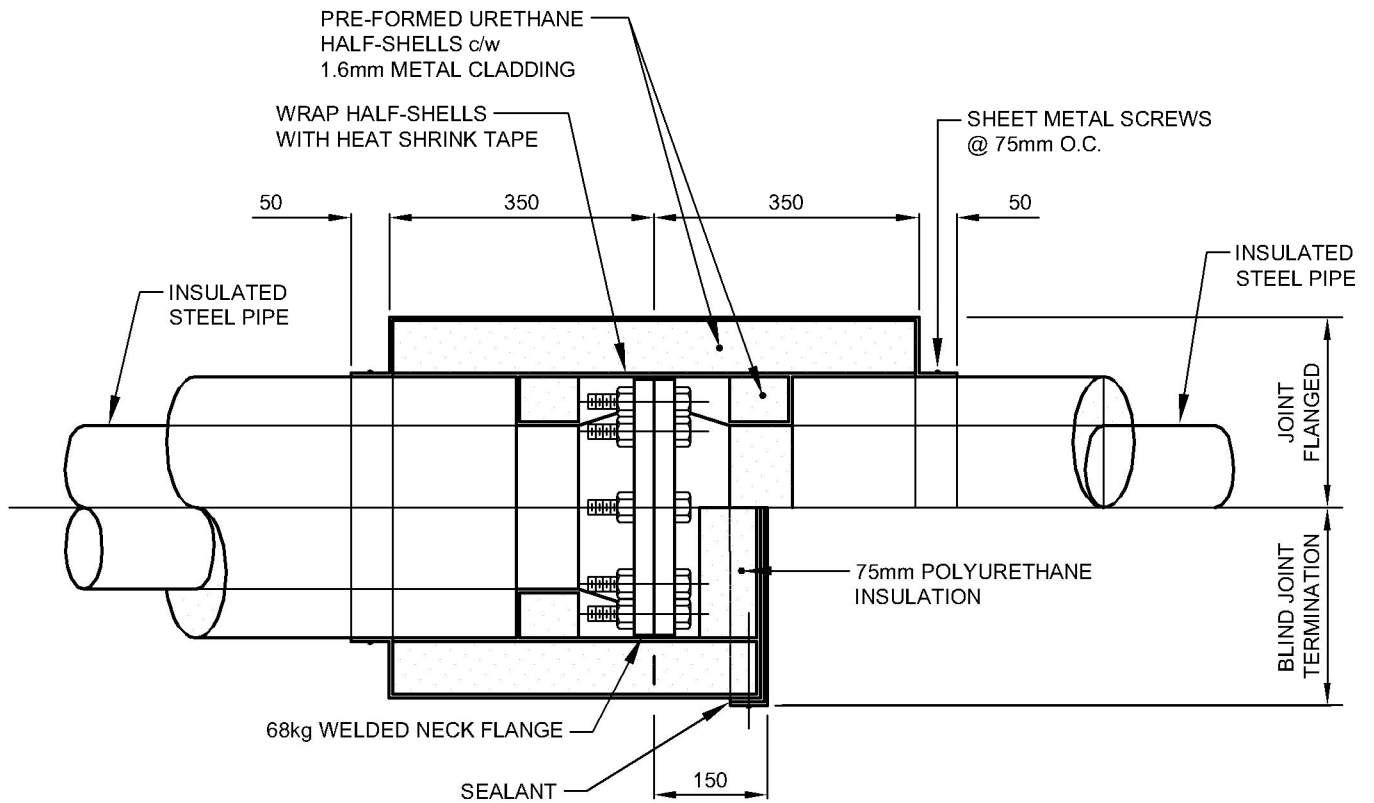

NOTES:

1. COAT ALL EXPOSED SURFACES WITH MASTIC.
2. ALL DIMENSIONS IN MILLIMETERS UNLESS NOTED OTHERWISE.



1:10

DATE DRAWN:
01/01/20

REVISION DATE:
06/04/2022

APPROVED BY:
YK ENG.

TITLE:

FLANGED JOINT DETAIL

SANITARY

REVISION No.
1

DWG.No.

C-S-106

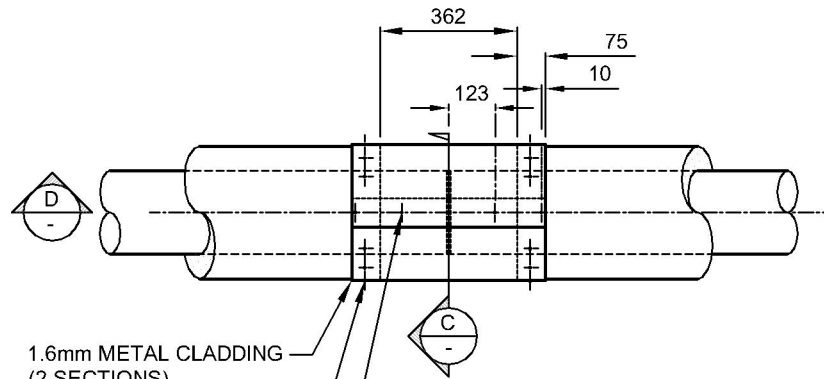

1.6mm METAL CLADDING
(2 SECTIONS)
SHEET METAL SCREWS
@ 75mm O.C.
SHEET METAL SCREWS

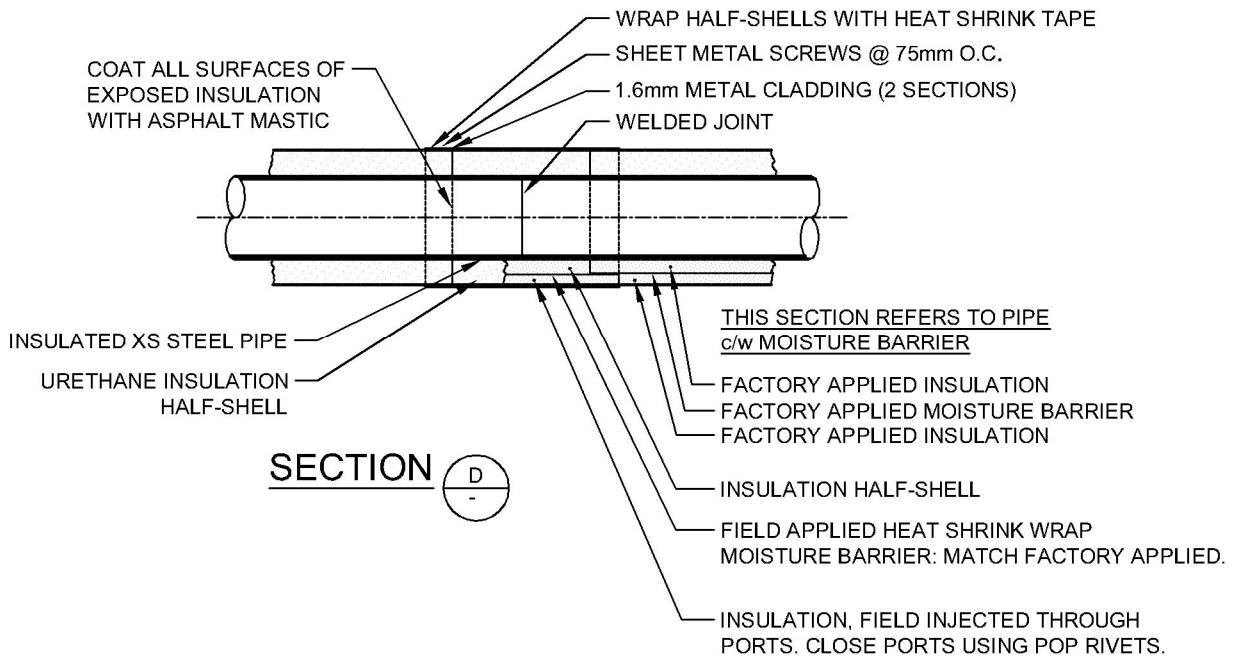
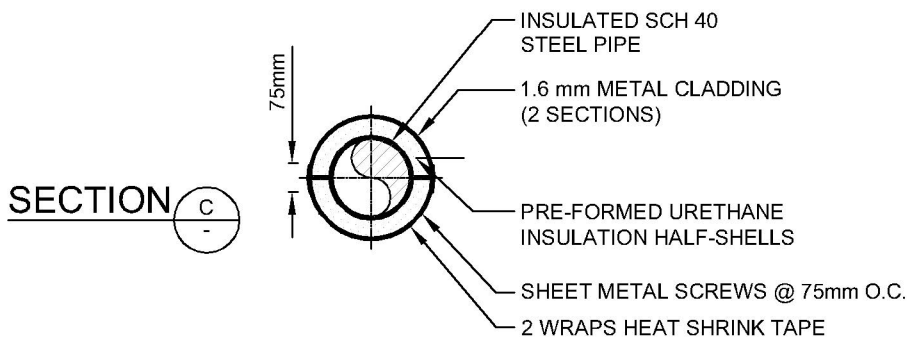

1:20	
DATE DRAWN: 01/01/20	REVISION DATE: 06/04/2022
APPROVED BY: YK ENG.	

TITLE: TYPICAL WELDED JOINT DETAIL		
SANITARY	REVISION No. 1	DWG.No. C-S-107

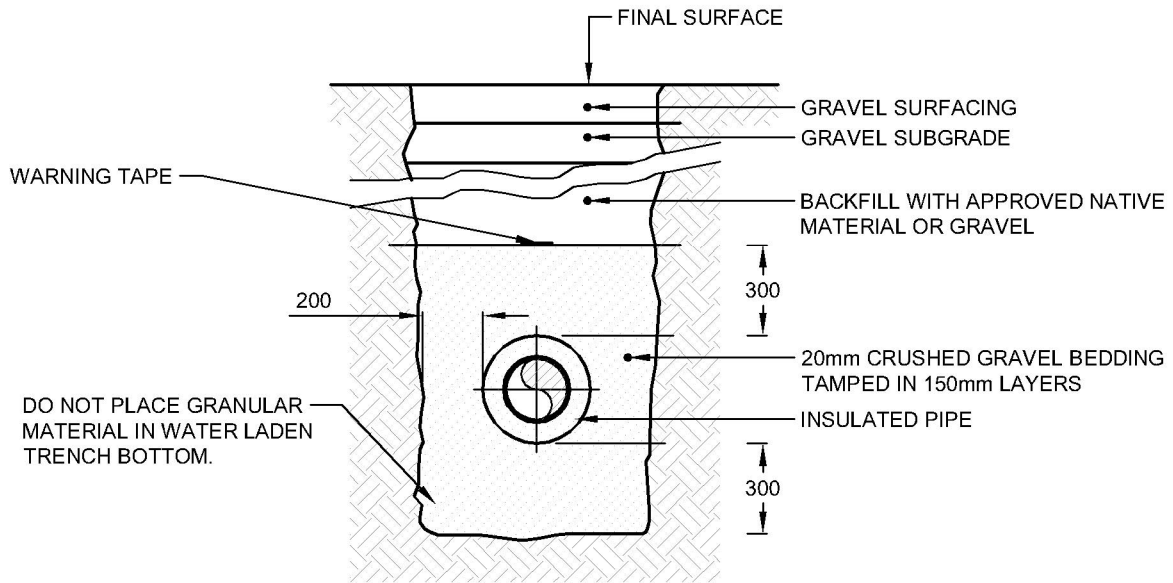

NOTES:

1. IN SOFT OR UNSTABLE GROUND CONDITIONS (FROZEN OR UNFROZEN), UNDERCUT SUBGRADE AS DIRECTED BY ENGINEER (SEE DWG. C-T-101).
2. SEE SHEET C-T-101 FOR DETAIL OF COMBINED TRENCH



1:25

DATE DRAWN:
01/01/2020

REVISION DATE:
06/04/2022

APPROVED BY:
YK ENG.

TITLE:

TYPICAL SANITARY SEWER BEDDING

SANITARY

REVISION No.
1

DWG.No.

C-S-108

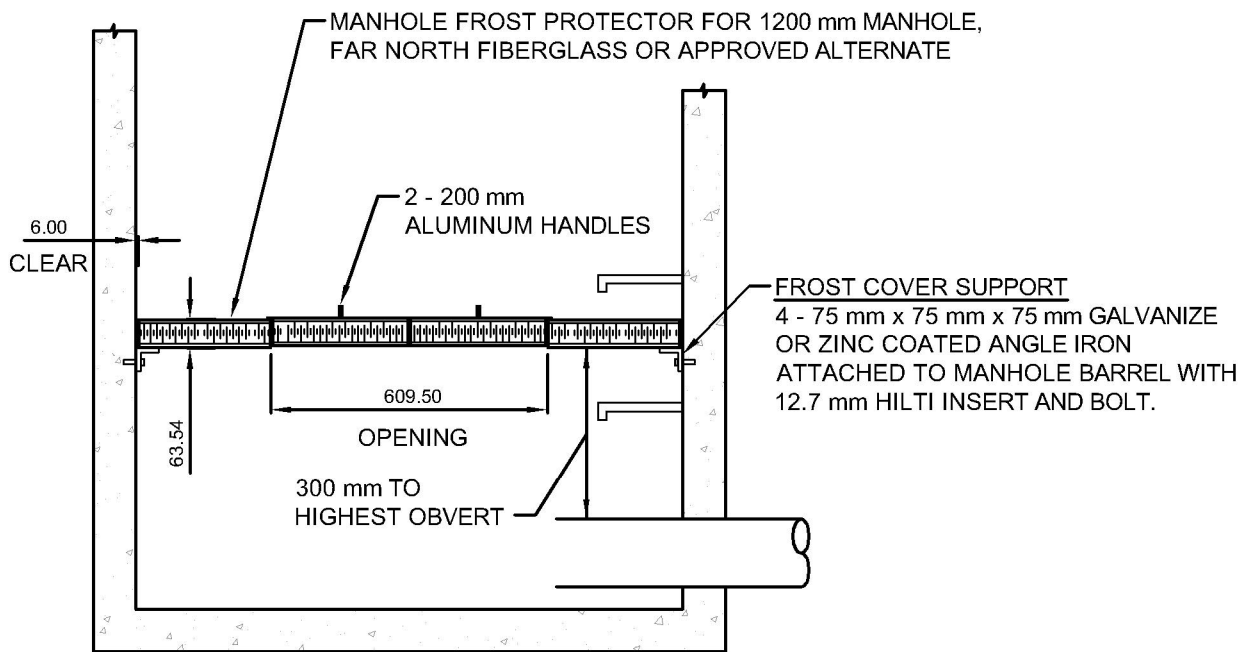

SECTION

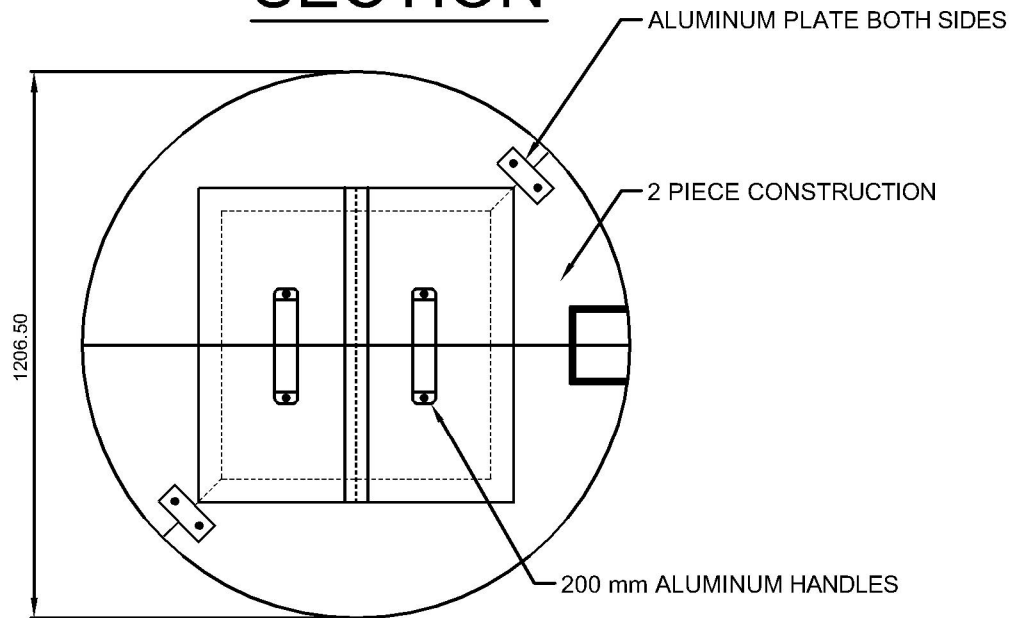

PLAN



N.T.S.

TITLE:

SANITARY MANHOLE FROST COVER LID

DATE DRAWN:
01/01/2020

REVISION DATE:
06/04/2022

APPROVED BY:
YK ENG.

SANITARY

REVISION No.
1

DWG.No.

C-S-109

"STORM" WARNING TAPE

GREATER OF:
1) 300mm
2) 0.5 Ø OF PIPE.

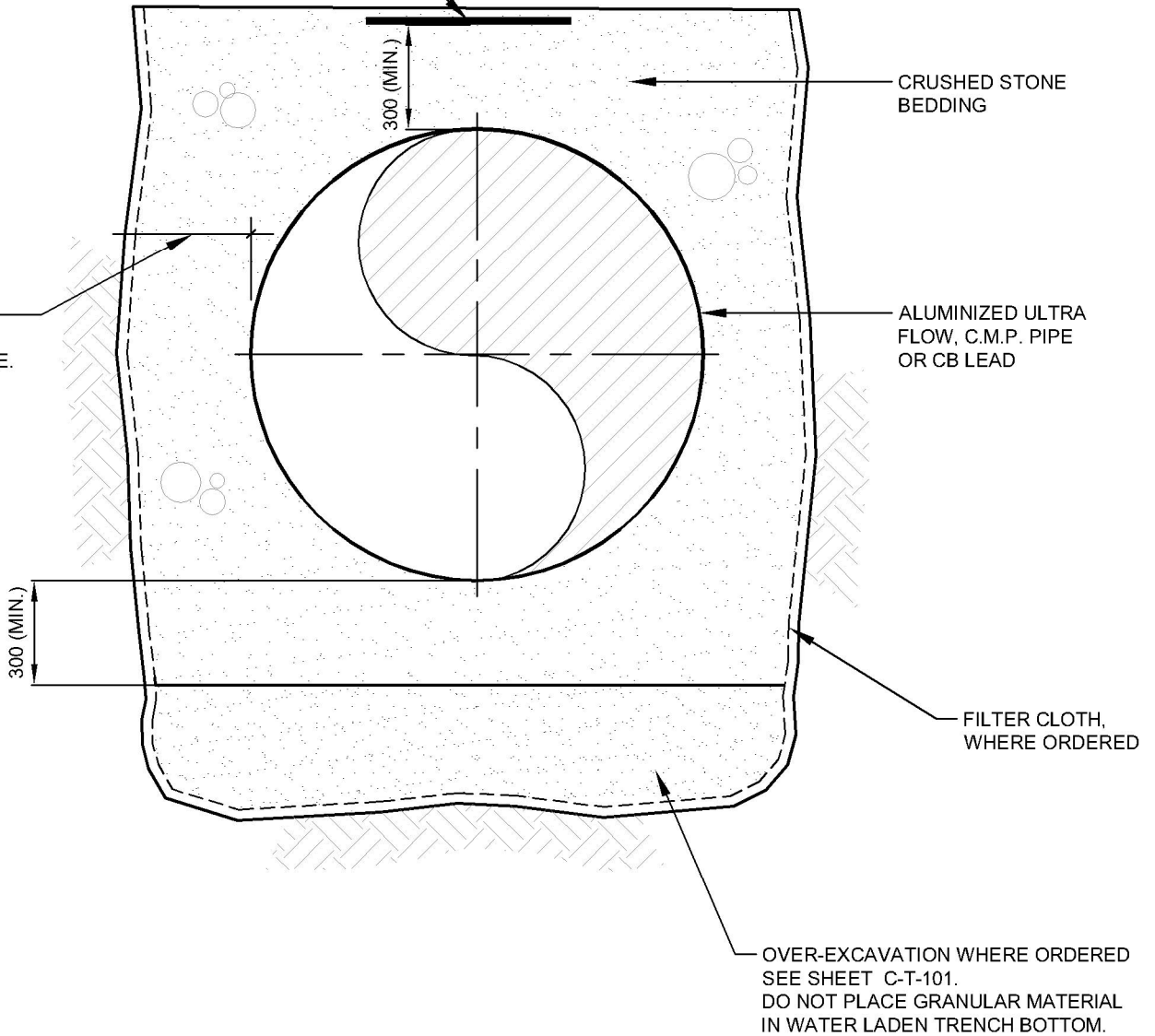

1:20

DATE DRAWN:
01/01/20

REVISION DATE:
06/04/2022

APPROVED BY:
D.MCMILLAN

TITLE:

TYPICAL STORM SEWER BEDDING

STORM

REVISION No.
1

DWG.No.

C-ST-100

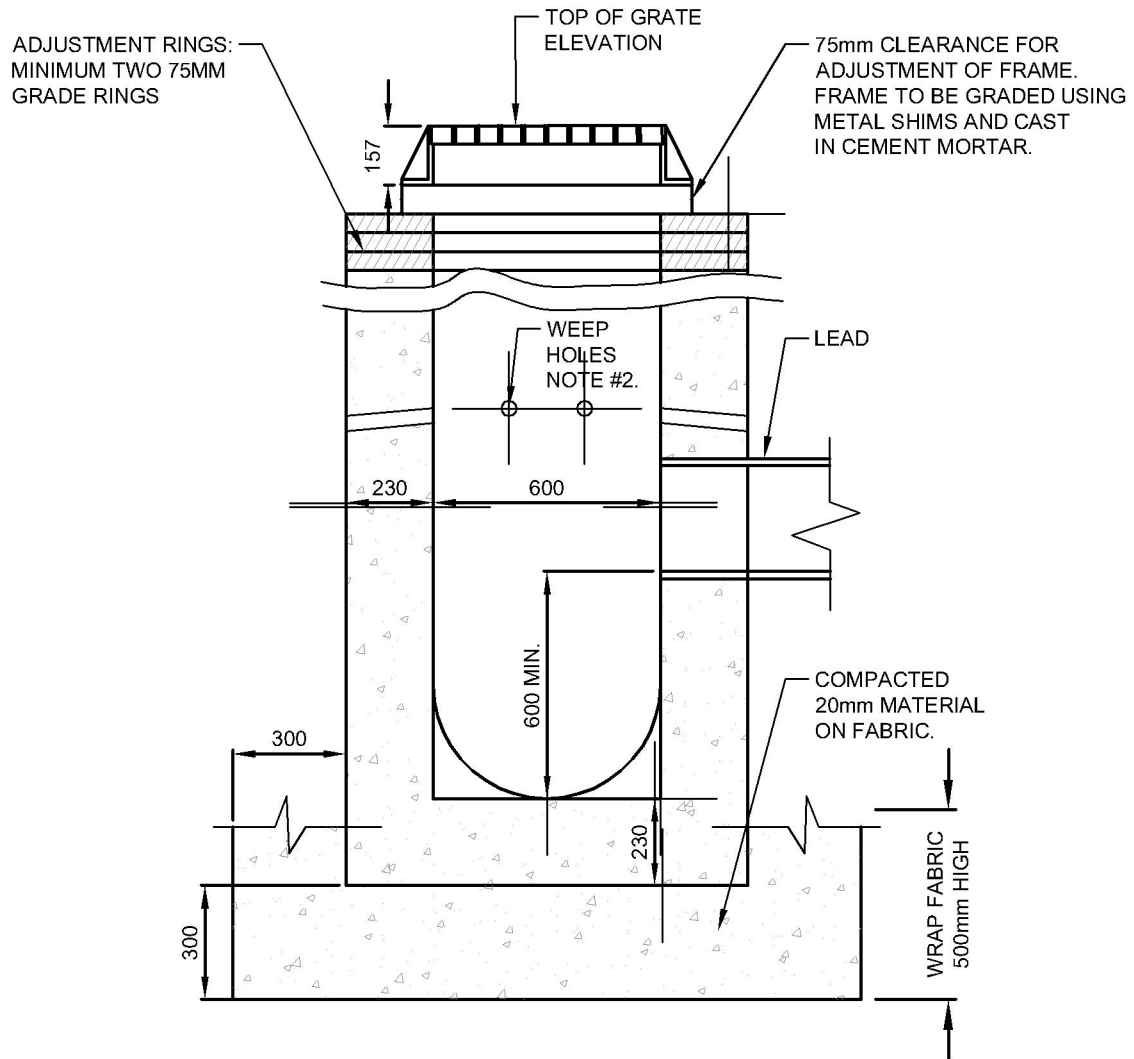

NOTES:

1. TO PERMIT USE OF COLLAPSIBLE FORMS, SEMI-CIRCULAR BOTTOM MAY BE EMPLOYED AT CONTRACTOR'S OPTION.
2. WEEP HOLES OPTIONAL - 40mm Ø. HOLES SHALL BE PLACED SO THAT THE BOTTOM OF THE WEEPER INSIDE AND TOP OF WEEPER OUTSIDE ARE LEVEL.
3. 20mm GRANULAR BACKFILL TO BE PLACED TO MIN. THICKNESS OF 300mm ALL SIDES.
4. FILTER FABRIC IN BOTTOM OF CATCH BASIN EXCAVATION AND FOR 500mm HIGH AROUND SIDES.
5. CLASS OF CONCRETE - 25 MPa AT 28 DAYS.
6. ALL DIMENSIONS ARE IN MILLIMETERS UNLESS NOTED OTHERWISE.



1:20

DATE DRAWN:
01/01/20

REVISION DATE:
06/04/2022

APPROVED BY:
YK ENG.

TITLE:

CONCRETE CATCH BASIN

STORM

REVISION No.
1

DWG.No.

C-ST-101

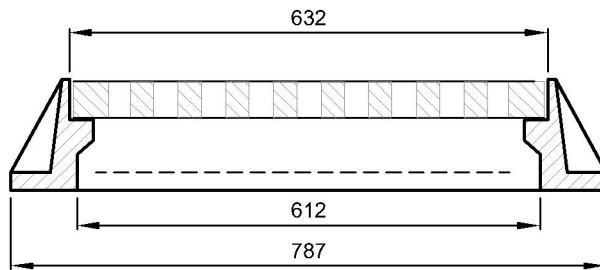
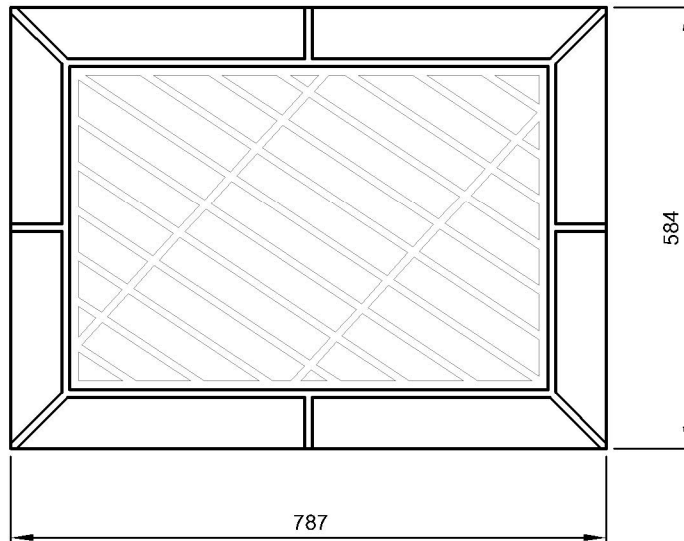

1:10

DATE DRAWN:
01/01/20

REVISION DATE:
06/04/2022

APPROVED BY:
D.MCMILLAN

TITLE:

TYPE NF-51 CATCH BASIN FRAME AND COVER

STORM

REVISION No.
1

DWG.No.

C-ST-104

NOTE: USE CONE IN PLACE OF FLAT TOP WHERE DEPTH OF BURY WILL PERMIT.

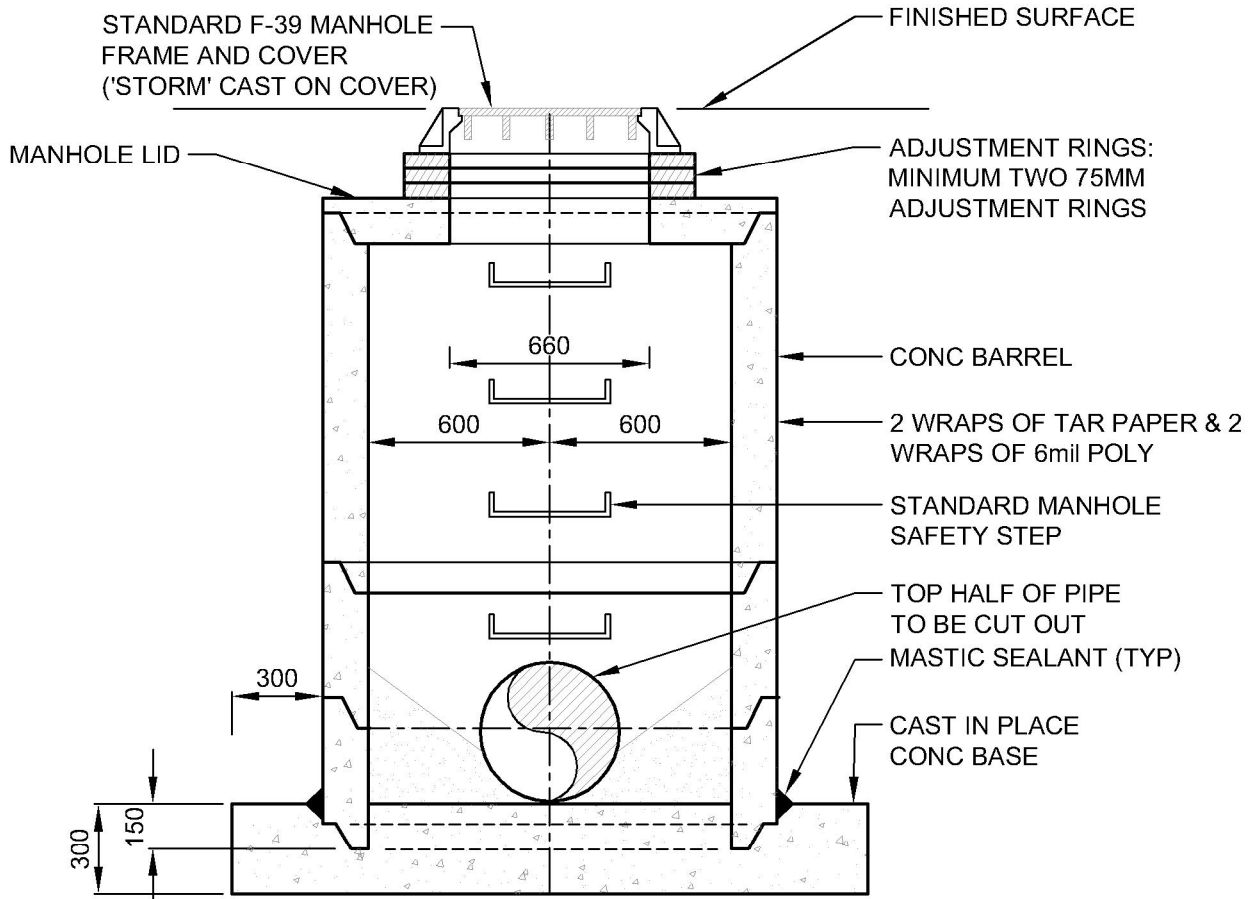

1:25

DATE DRAWN:
01/01/20

REVISION DATE:
06/04/2022

APPROVED BY:
YK ENG.

TITLE:

1200mm Ø MANHOLE - ALTERNATIVE No.1 FOR
STORM PIPES 550mm Ø or LESS

STORM

REVISION No.
1

DWG.No.

C-ST-105

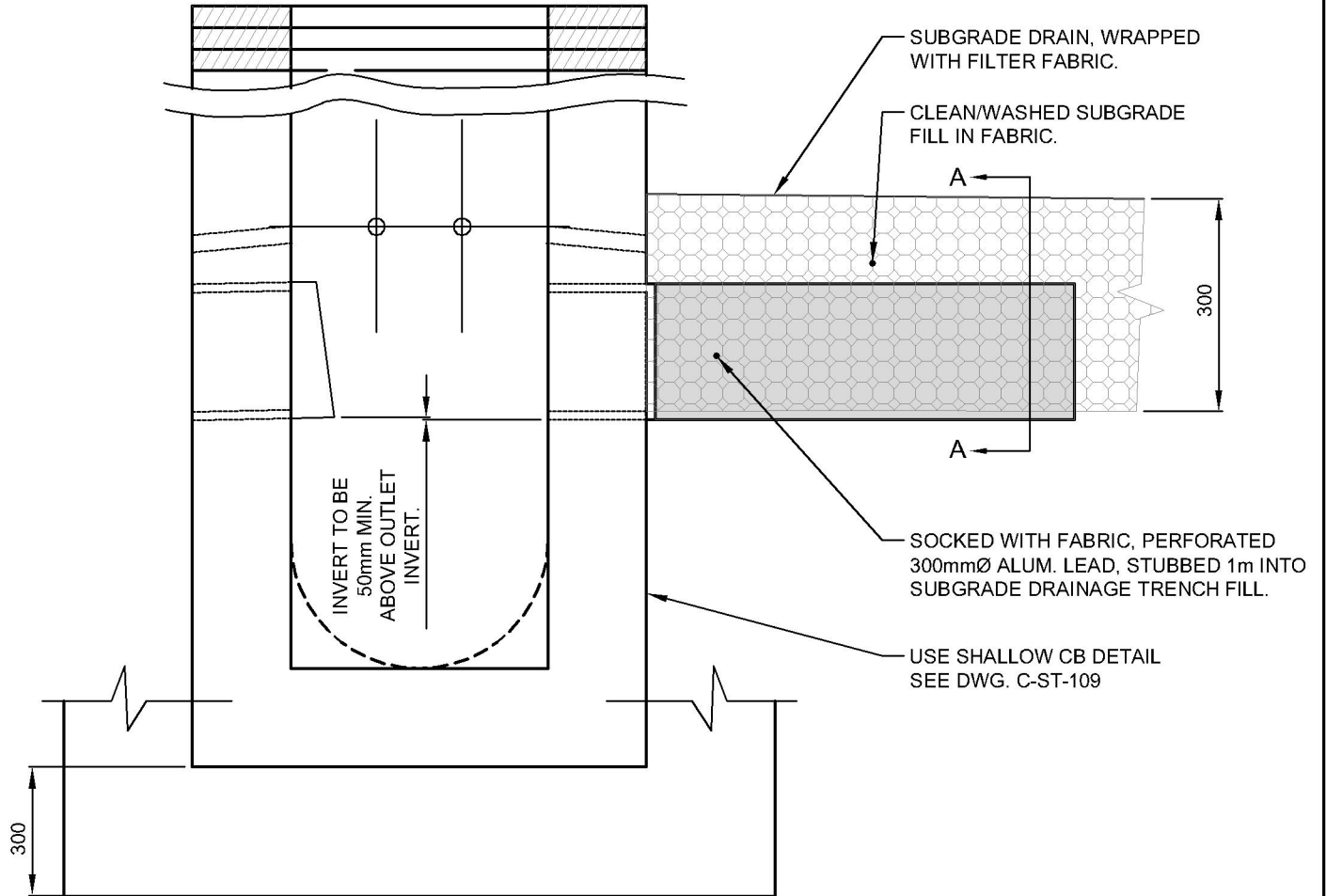

1:10

DATE DRAWN:
01/01/2020

REVISION DATE:
06/04/2022

APPROVED BY:
YK ENG.

TITLE:

SUBGRADE DRAIN TIE-IN

STORM

REVISION No.
1

DWG.No.

C-ST-106

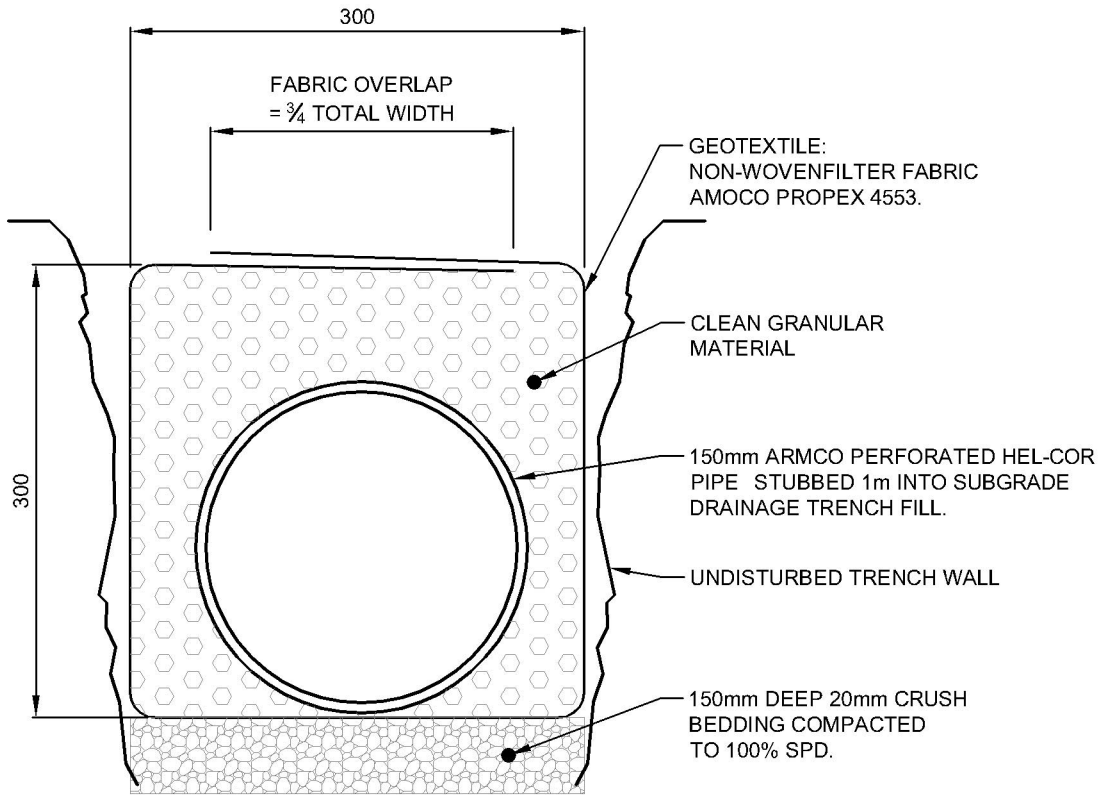

1:5

DATE DRAWN:
01/01/20

REVISION DATE:
06/04/2022

APPROVED BY:
D.MCMILLAN

TITLE:

SUBGRADE DRAIN TIE-IN SECTION A-A

STORM

REVISION No.
1

DWG.No.

C-ST-107

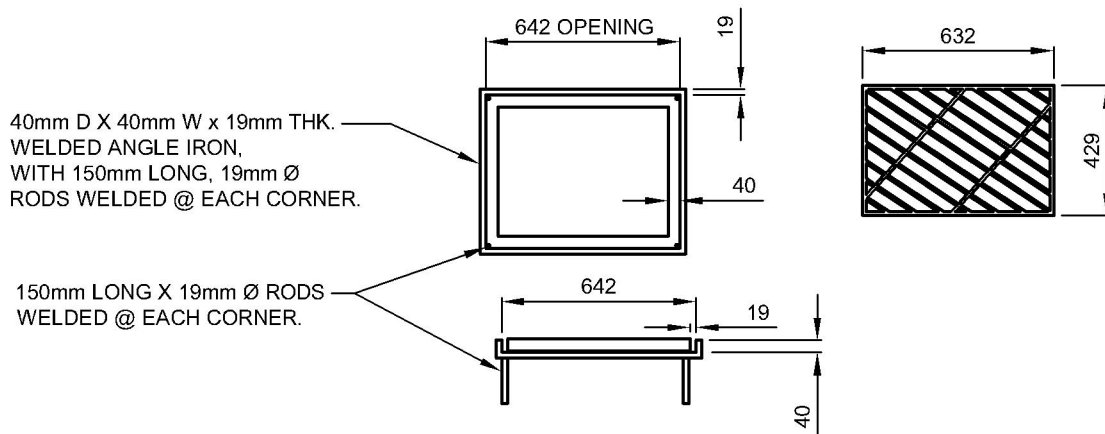
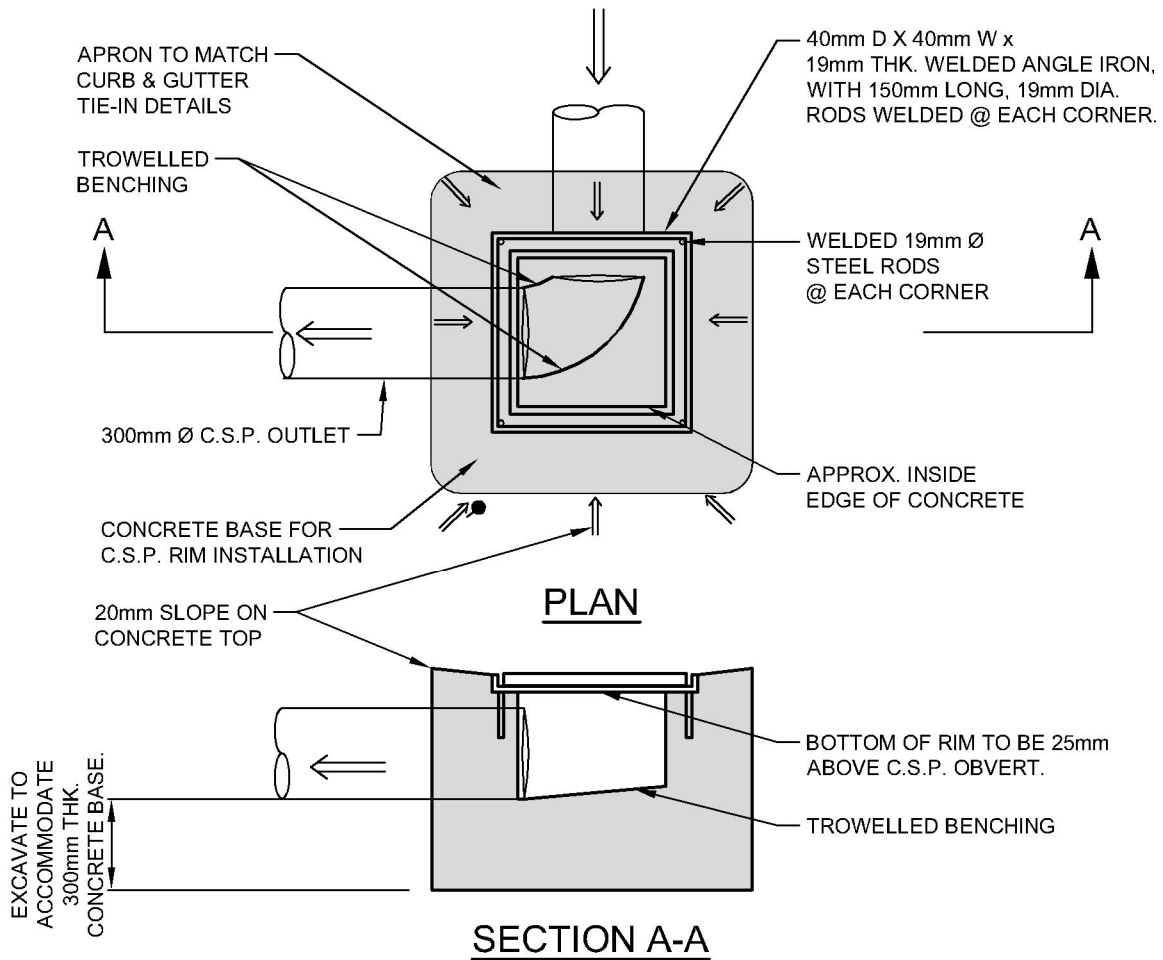

**SHALLOW CATCH BASIN
WELDED RIM FRAME - DETAIL**



	1:25		TITLE:		
	DATE DRAWN:	REVISION DATE:	SHALLOW CATCH BASIN		
	01/01/20	06/04/2022			
APPROVED BY:		STORM		REVISION No.	
D.MCMILLAN				1	
				DWG.No.	
				C-ST-108	

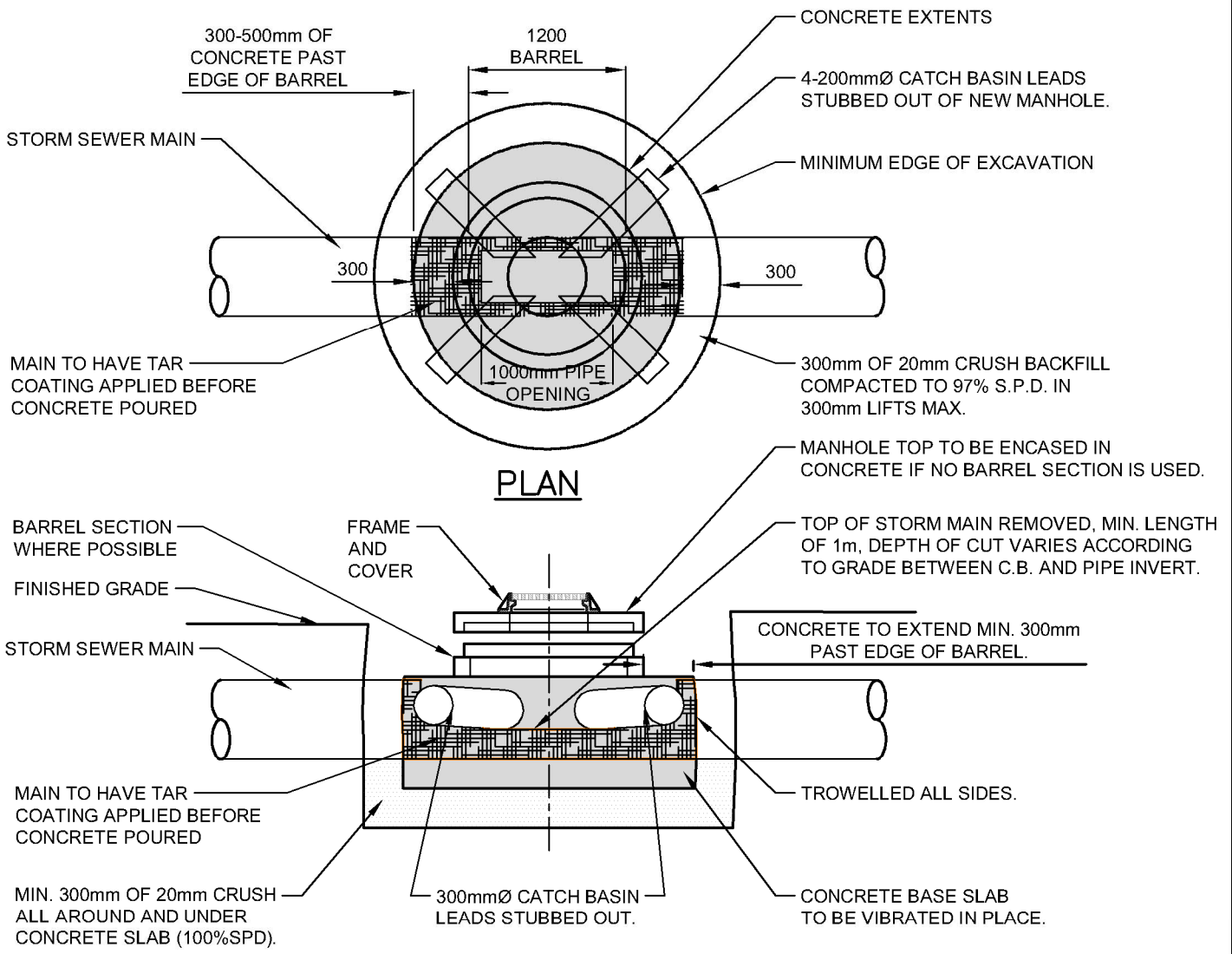

NOTES:

1. ALL JOINTS TO BE TARRED.
2. RUBBER GASKET REQUIRED IF BARREL AND TOP USED.
3. CONCRETE TO BE VIBRATED IN PLACE WITH MECHANICAL VIBRATOR.
4. WHERE POSSIBLE, WALLS TO BE FORMED WITH PLYWOOD TO PROVIDE UNIFORM BACKFILL SURFACE.



1:50	
DATE DRAWN: 01/01/20	REVISION DATE: 06/04/2022
APPROVED BY: D.MCMILLAN	

TITLE: SHALLOW COVER CAST IN PLACE		
STORM	REVISION No. 1	DWG.No. C-ST-109

-FACTORY WELD ALL AROUND
 -SPECIFIED FIELD WELD AND
 COATING OF PIPE IS ACCEPTABLE
 -SEE NOTE FOR ALUMINIZED ULTRA
 FLOW STORM.

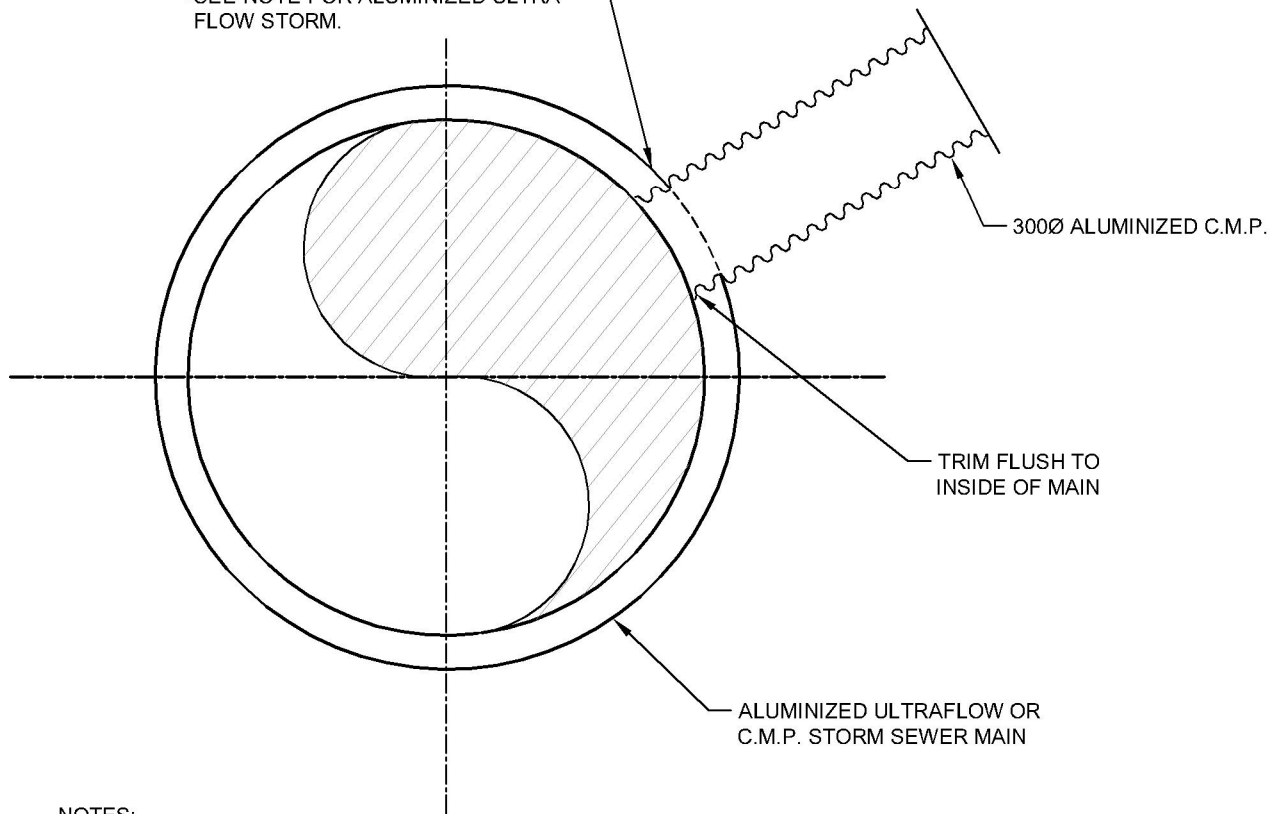

NOTES:

1. USE ONLY WHERE AUTHORIZED BY ENGINEER.



1:20

DATE DRAWN:
01/01/20

REVISION DATE:
06/04/2022

APPROVED BY:
D.MCMILLAN

TITLE:

CATCH BASIN LEAD TO MAIN CONNECTION

STORM

REVISION No.
1

DWG.No.

C-ST-110

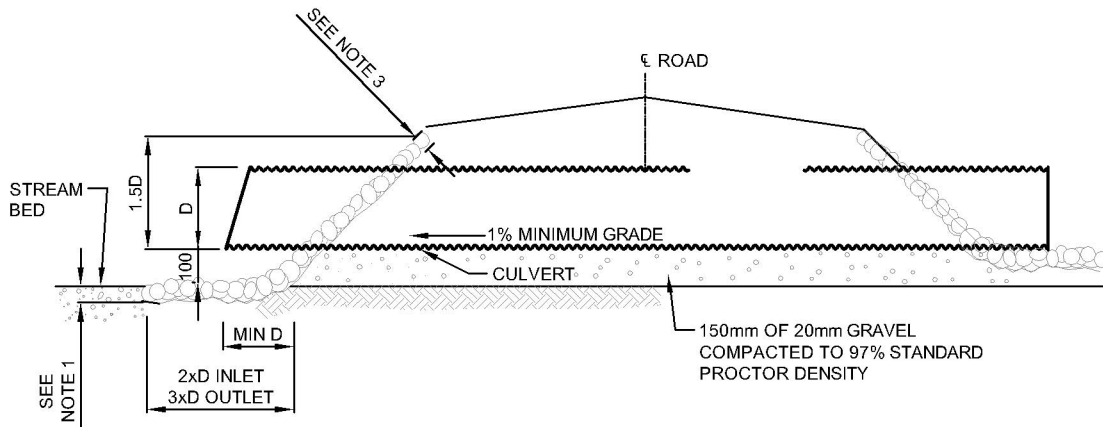

SECTION "A-A" CULVERT INLET AND OUTLET
SCALE N.T.S.

NOTES:

1. MINIMUM CULVERT DIAMETER 300mm
2. RIP RAP SHALL BE HAND PLACED ROCK COBBLE OR BAGGED CONCRETE AS SPECIFIED BY THE ENGINEER.
3. RIP RAP THICKNESS:
 - 300mm (D SMALLER THAN 1400mm)
 - 600mm (D= 1400-2000mm)
4. 100mm DROP FROM BOTTOM OF CULVERT TO RIP RAP IS FOR OUTLET END ONLY
5. PLAN VIEW - CULVERT TO BE PLACED AT THE
6. BEGINNING OF CURVE OF THE CURB RETURN

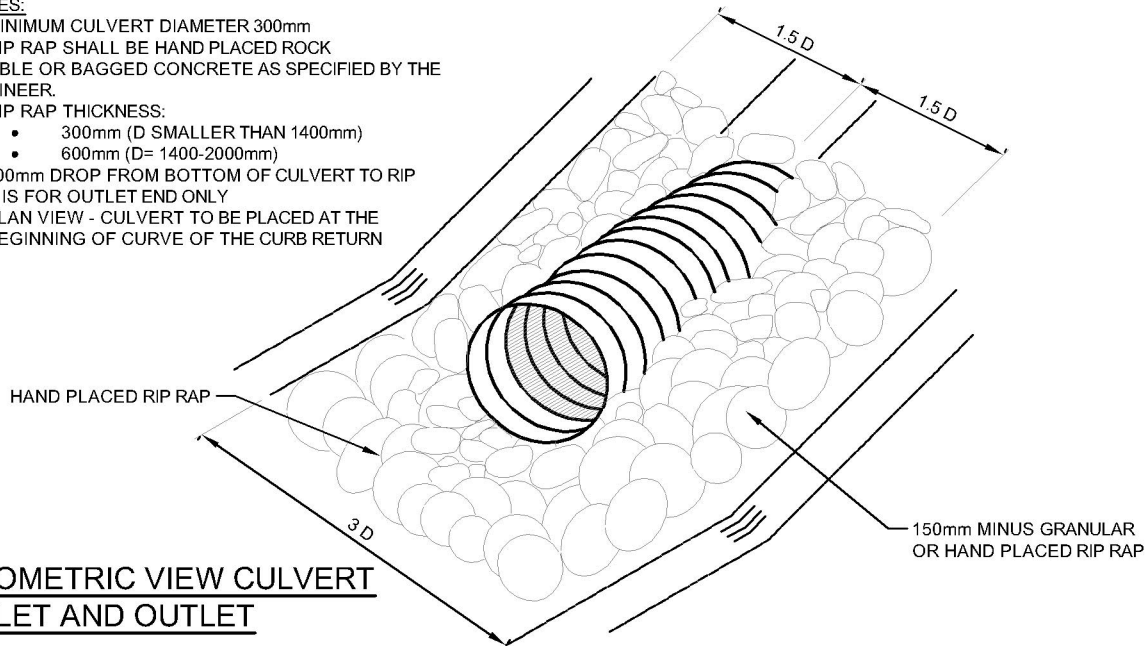

ISOMETRIC VIEW CULVERT INLET AND OUTLET

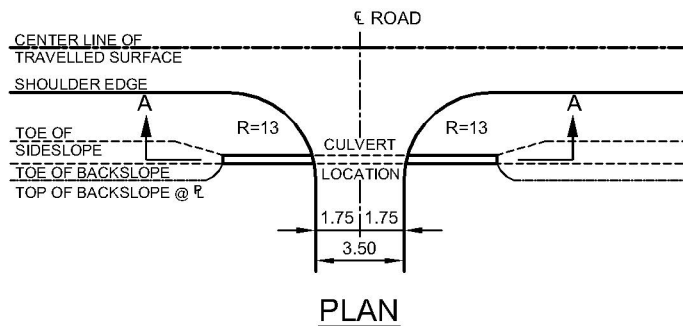

N.T.S.	TITLE:		TYPICAL CULVERT INSTALLATION WITH RIP RAP END TREATMENT	
	DATE DRAWN:	REVISION DATE:		
	01/01/20	06/04/2022		
APPROVED BY:	STORM		REVISION No.	DWG.No.
YK ENG.			1	C-ST-111

HUGGER BAND C/W JS-701
COUPLER SEALANT

ALUMINIZED ULTRA FLOW
OR C.M.P. C/W
FACTORY ENDS ONLY

12mm NUTS & BOLTS
(4 PER BAND)

FACTORY ENDS ONLY

20Ø NEOPRENE GASKET
(2 PER BAND)

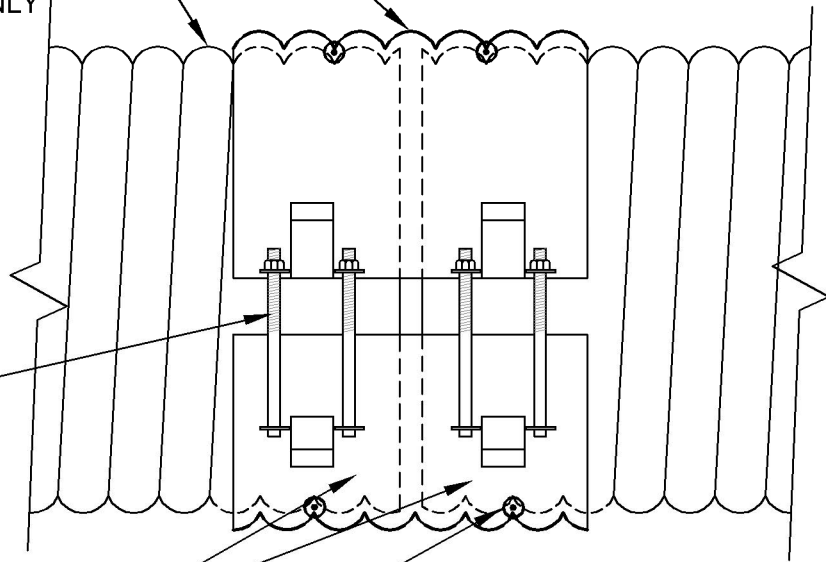

SIDE VIEW



N.T.S.

DATE DRAWN:
01/01/20

REVISION DATE:
06/04/2022

APPROVED BY:
D.MCMILLAN

TITLE:

JOINT DETAIL

STORM

REVISION No.
1

DWG.No.

C-ST-112

RIP RAP

- DENSE DURABLE ROCK OBTAINED FROM BLAST ROCK
- WELL GRADED WITH 95% PASSING 300 mm SCREEN AND NOT MORE THAN 5% PASSING 150mm SCREEN
- LARGEST DIMENSION OF INDIVIDUAL PIECES TO BE NOT GREATER THAN TWICE THE SHORTEST DIMENSION
- DO NOT USE LONG FLAT STONES

NOTES:

1. END SECTION SHALL BE 2.0 mm C.S.P. AS MANUFACTURED BY ARMTEC OR APPROVED EQUAL.
2. TRASH GRILL AS FABRICATED BY ARMTEC, HINGED ONE SIDE. PADLOCK HASP ON OTHER SIDE.

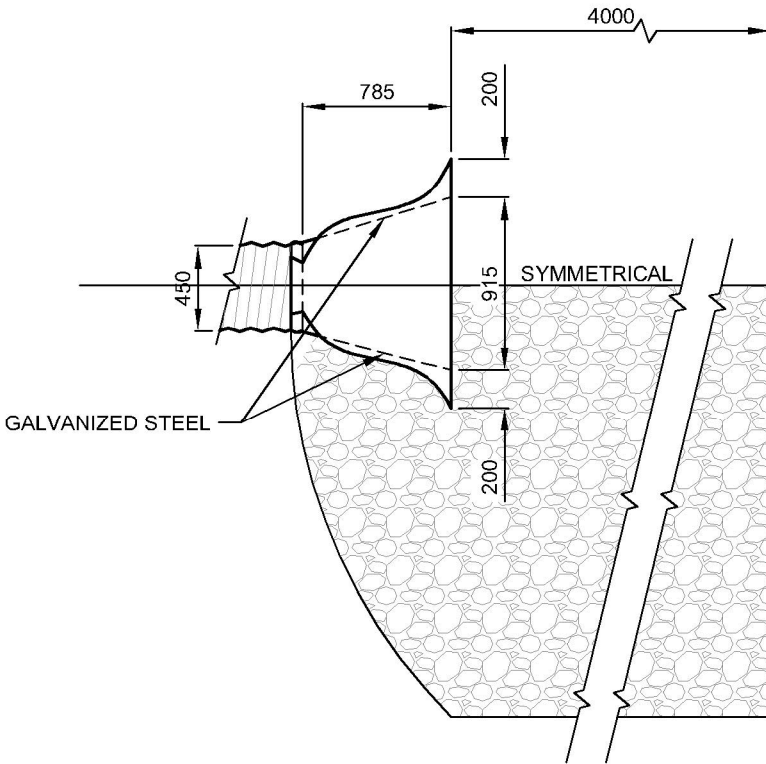

PLAN

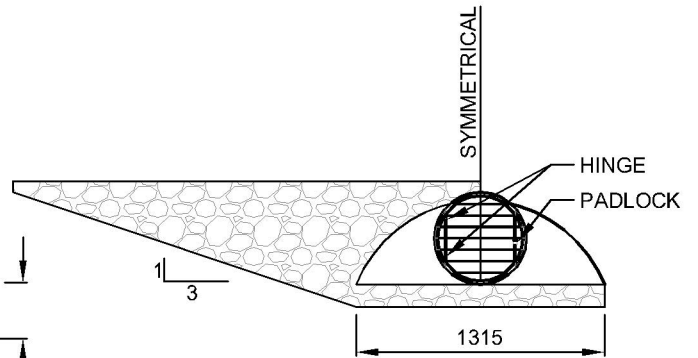
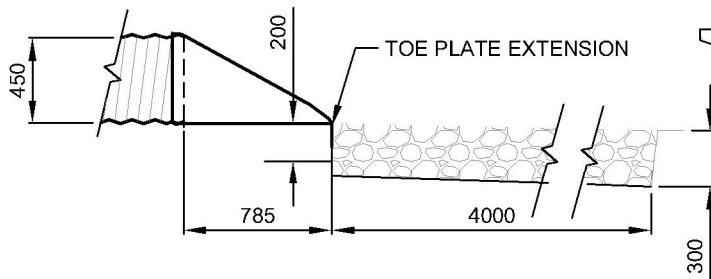

ELEVATION

**STORM DRAIN OUTFALL
FLARED END SECTION**



1:40

DATE DRAWN:
01/01/20

REVISION DATE:
06/04/2022

APPROVED BY:
D.MCMILLAN

TITLE:

STORM DRAIN OUTFALL

STORM

REVISION No.
1

DWG.No.

C-ST-113

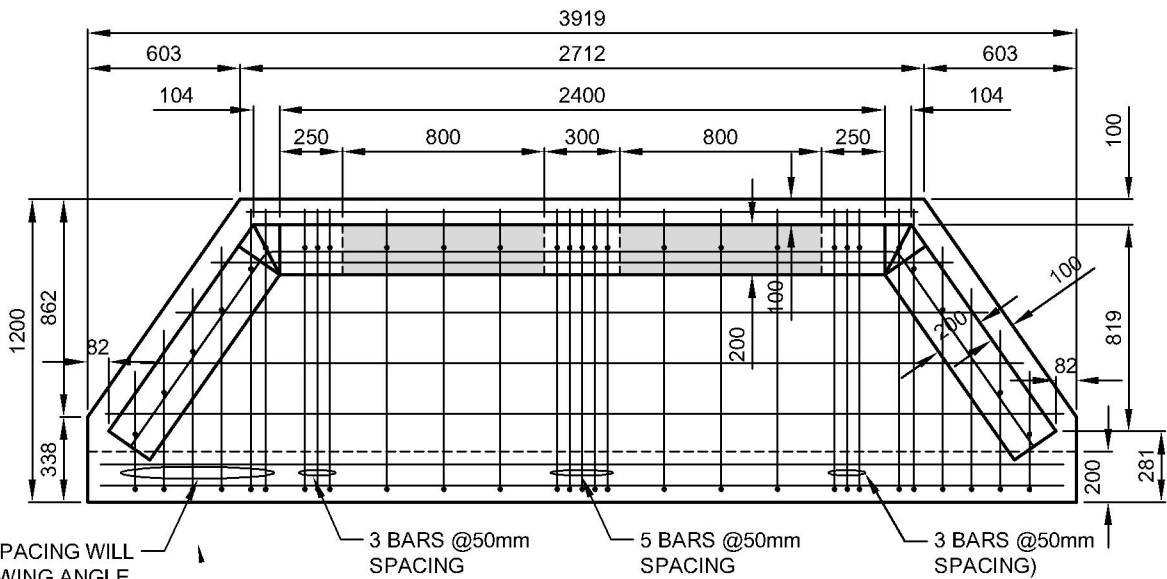

PLAN VIEW

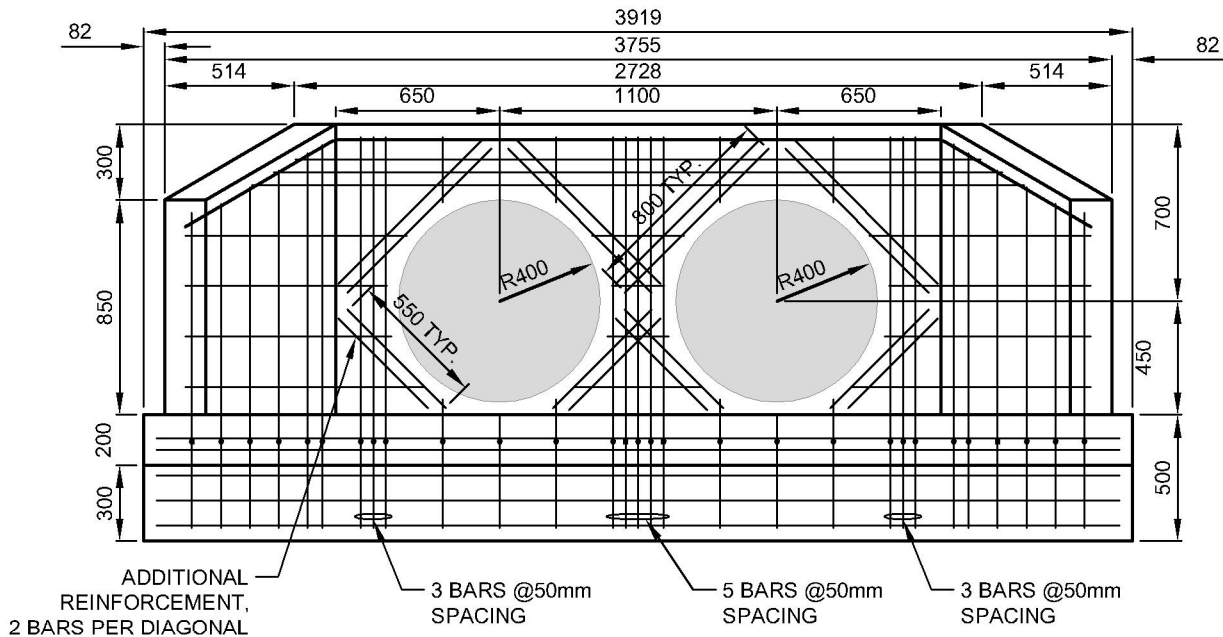

FRONT VIEW (PROFILE)

NOTES:

1. ALL CONCRETE SHALL HAVE 28 DAY COMPRESSIVE STRENGTH OF 25MPa, MAXIMUM AGGREGATE SIZE OF 20mm AND AIR ENTRAINED 5-8%.
2. ALL STEEL REINFORCING BARS SHALL BE BILLET STEEL CONFORMING TO CSA G30.18, GRADE 400EW.
3. ALL SPLICES IN REINFORCEMENT SHALL BE 40 TIMES THE LARGER BAR DIAMETER.
4. ALL BENDS IN REINFORCEMENT SHALL HAVE A MINIMUM RADIUS OF 3 TIMES THE BAR DIAMETER.
5. BED BASE OF WING-WALL WITH 300mm OF 50mm MINUS AND COMPACT TO 100% STANDARD PROCTOR DENSITY.
6. UNLESS OTHERWISE NOTED, ALL BARS SHALL BE 15M SPACED AT 200mm ON-CENTER AND PLACED AT MID-DEPTH OF THE WALL OR SLAB.
7. DO NOT WELD REINFORCEMENT.
8. WHERE POSSIBLE, CAST WALL AROUND CULVERT. OTHERWISE, FORM OPENING TO 850mmØ AND GROUT BETWEEN WALL AND CULVERT.
9. PROVIDE ADDITIONAL DIAGONAL REINFORCEMENT AROUND CULVERTS AS SHOWN.
10. PROVIDE 38x140mm KEY AT COLD JOINT BETWEEN WALL AND BASE.



1:30	
DATE DRAWN: 01/01/20	REVISION DATE: 06/04/2022
APPROVED BY: D.MCMILLAN	

TITLE: DOUBLE CULVERT WING-WALL DETAIL	
STORM	REVISION No. 1
	DWG.No. C-ST-114

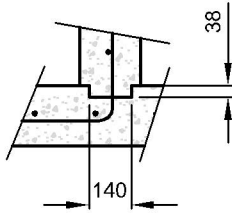

KEY-WAY DETAIL

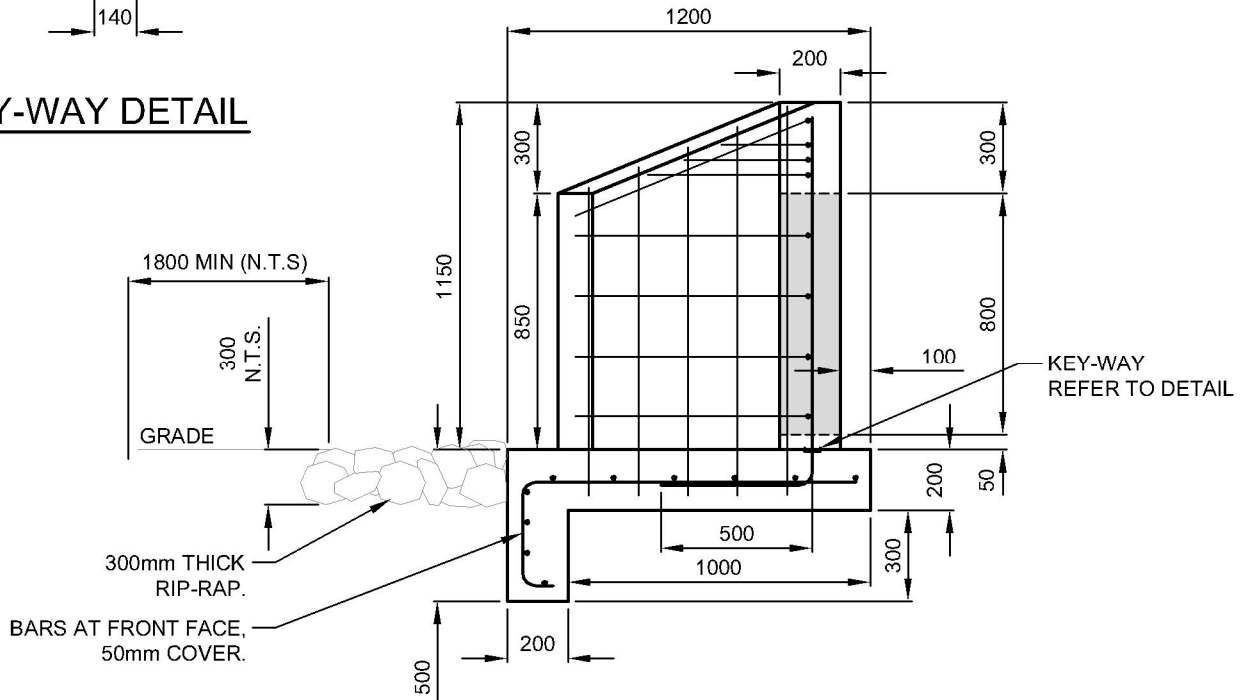

END VIEW

NOTES:

1. ALL CONCRETE SHALL HAVE 28 DAY COMPRESSIVE STRENGTH OF 25MPa, MAXIMUM AGGREGATE SIZE OF 20mm AND AIR ENTRAINED 5-8%.
2. ALL STEEL REINFORCING BARS SHALL BE BILLET STEEL CONFORMING TO CSA G30.18, GRADE 400EW.
3. ALL SPLICES IN REINFORCEMENT SHALL BE 40 TIMES THE LARGER BAR DIAMETER.
4. ALL BENDS IN REINFORCEMENT SHALL HAVE A MINIMUM RADIUS OF 3 TIMES THE BAR DIAMETER.
5. BED BASE OF WING-WALL WITH 300mm OF 50mm MINUS AND COMPACT TO 100% STANDARD PROCTOR DENSITY.
6. UNLESS OTHERWISE NOTED, ALL BARS SHALL BE 15M SPACED AT 200mm ON-CENTER AND PLACED AT MID-DEPTH OF THE WALL OR SLAB.
7. DO NOT WELD REINFORCEMENT.
8. WHERE POSSIBLE, CAST WALL AROUND CULVERT. OTHERWISE, FORM OPENING TO 850mmØ AND GROUT BETWEEN WALL AND CULVERT.
9. PROVIDE ADDITIONAL DIAGONAL REINFORCEMENT AROUND CULVERTS AS SHOWN.
10. PROVIDE 38x140mm KEY AT COLD JOINT BETWEEN WALL AND BASE.



1:25		TITLE: CULVERT WING-WALL SIDE VIEW	
DATE DRAWN: 01/01/20	REVISION DATE: 06/04/2022	STORM	
APPROVED BY: YK ENG.			

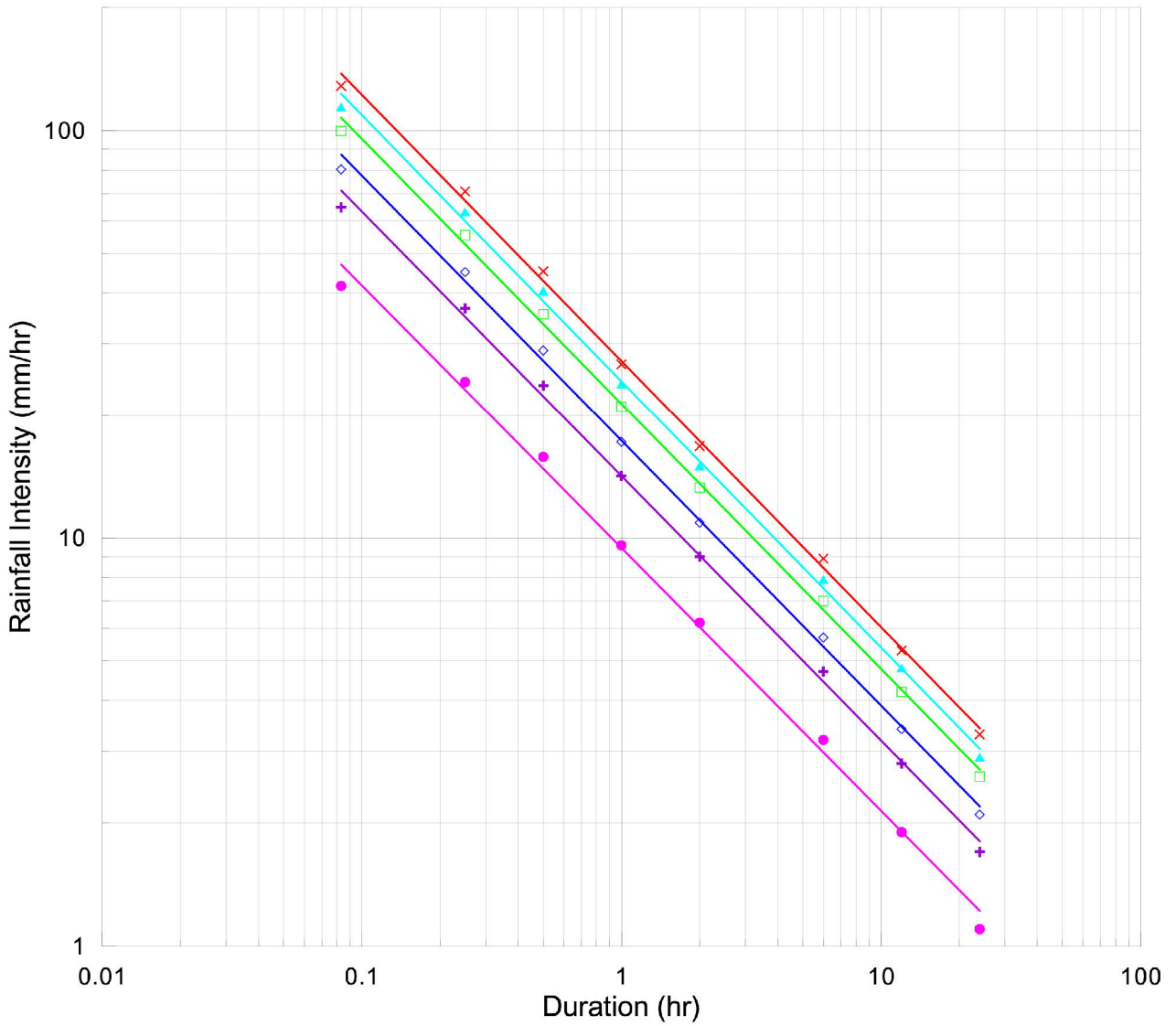

FOR REFERENCE ONLY
(see PIEVC Program)



N.T.S.

DATE DRAWN: 01/01/20	REVISION DATE: 06/04/2022
APPROVED BY: D.MCMILLAN	

TITLE: RAINFALL INTENSITY I-D-F CURVE	REVISION No. 1	DWG.No. C-ST-116
STORM		

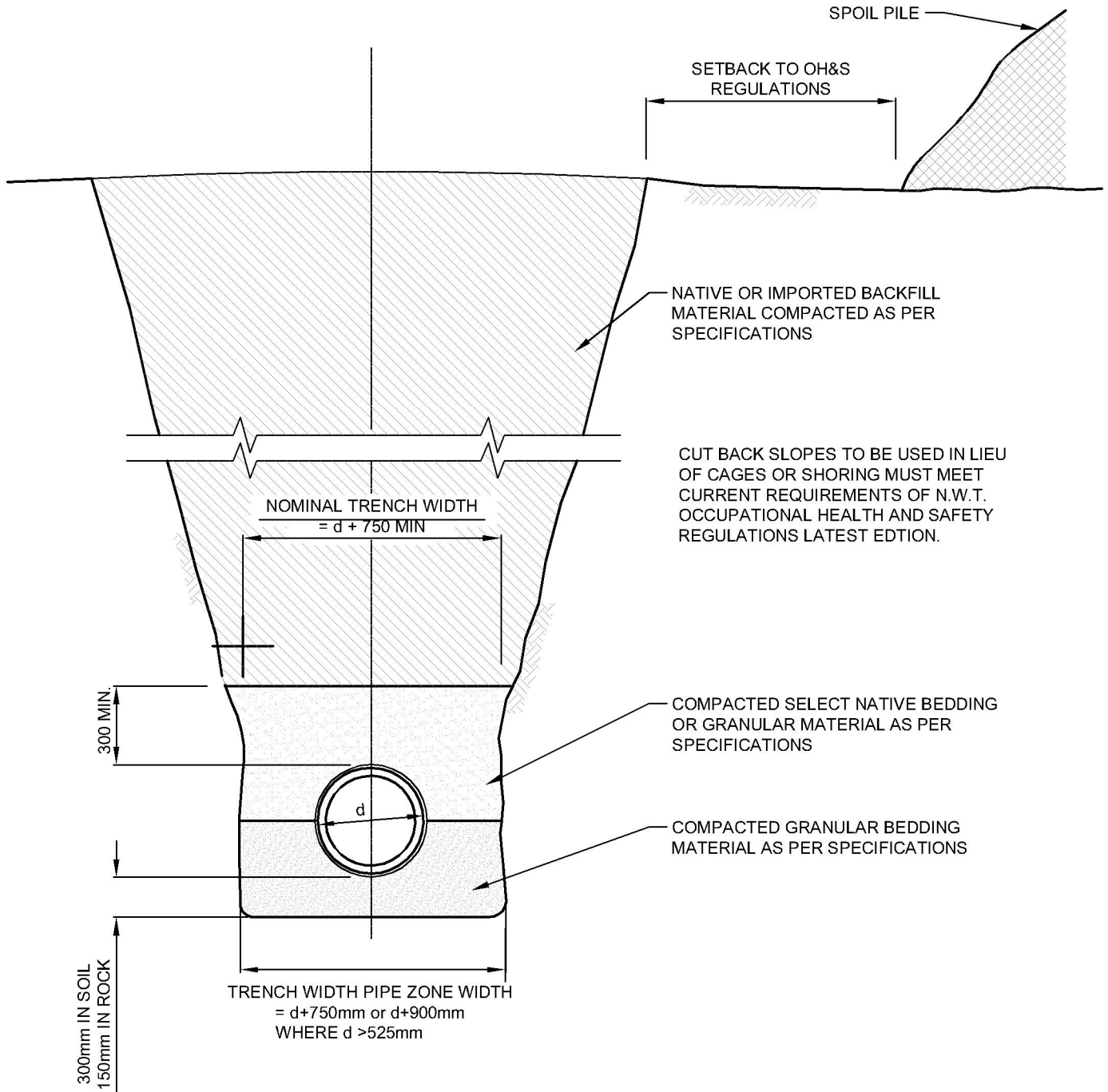

1:30	
DATE DRAWN: 01/01/20	REVISION DATE: 06/04/2022
APPROVED BY: D.MCMILLAN	

TITLE: TYPICAL TRENCH SECTION		
TRENCH	REVISION No. 1	DWG.No. C-T-100

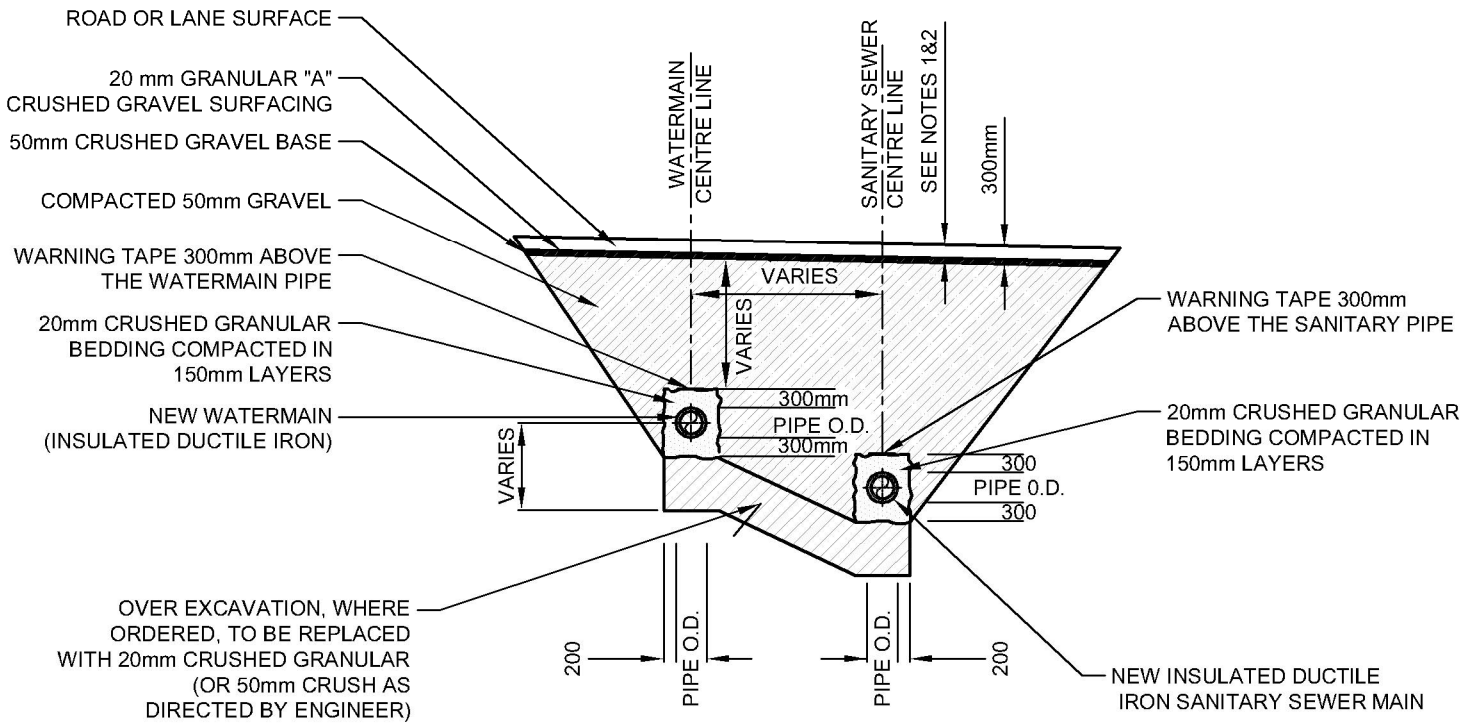

NOTES:

1. IN SOFT OR UNSTABLE GROUND CONDITIONS, FROZEN OR UNFROZEN, UNDERCUT SUBGRADE AS DIRECTED BY ENGINEER.
2. EXCAVATION CROSS SECTION MAY VARY WITH DISTANCE BETWEEN MAINS, DEPTH OF OVEREXCAVATION, AND SOIL CONDITIONS.



1:125

DATE DRAWN:
01/01/20

REVISION DATE:
06/04/2022

APPROVED BY:
YK ENG.

TITLE:

TYPICAL COMMON TRENCH DETAIL
SANITARY AND WATERMAIN

TRENCH

REVISION No.
1

DWG.No.

C-T-101

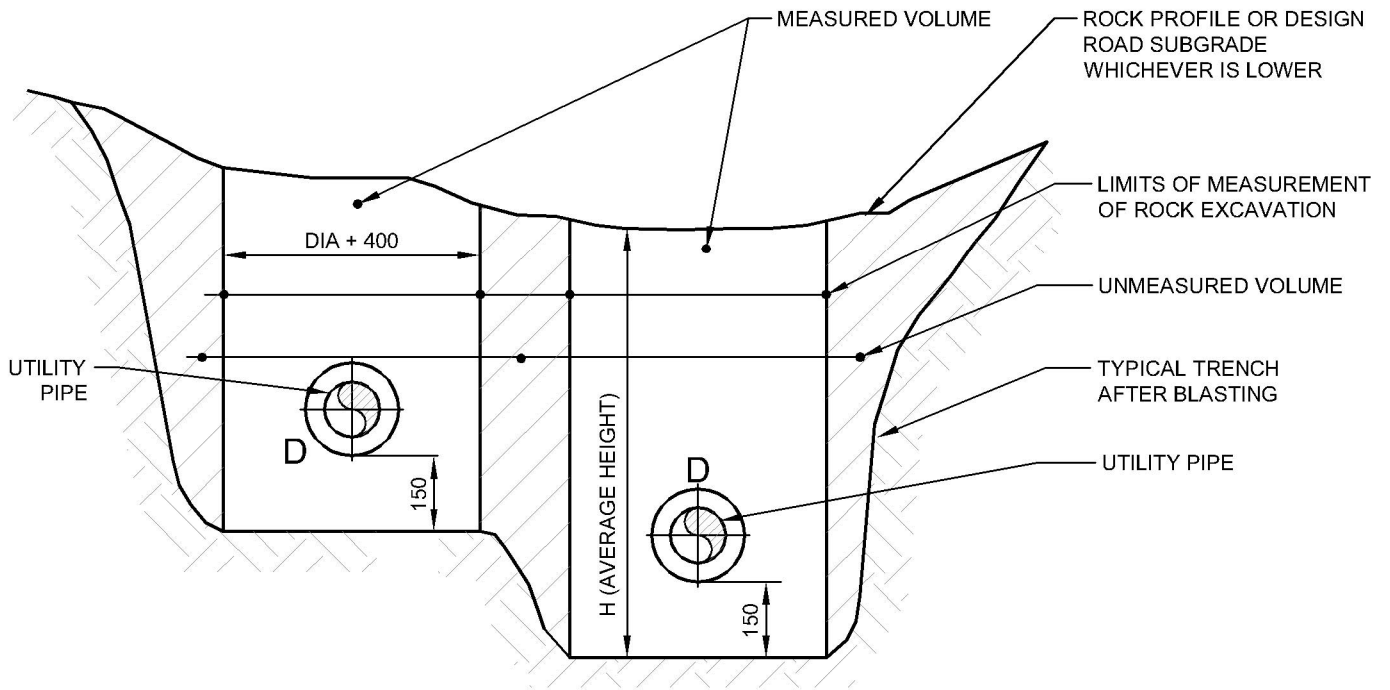

1. DIA. = OUTSIDE DIAMETER OF PIPE AND INSULATION (IF ANY)
2. ROCK EXCAVATION QUANTITY = $H \times (\text{DIA.} + 400\text{mm}) \times \text{LENGTH OF PIPE FOR EACH MAIN OR SERVICE PIPE}$
3. FOR STORM MAIN 600mm TO 1800mmØ ONLY
4. ROCK EXCAVATION QUANTITY = $H \times (\text{DIA.} + \text{DIA.}) \times \text{LENGTH OF STORM PIPE}$
5. ALL DIMENSIONS IN MILLIMETERS UNLESS NOTED OTHERWISE

FOR REFERENCE ONLY



N.T.S.

TITLE:

**TRENCH ROCK EXCAVATIONS
MEASUREMENTS - MAINS**

DATE DRAWN:
01/01/20

REVISION DATE:
06/04/2022

APPROVED BY:
D.MCMILLAN

TRENCH

REVISION No.
1

DWG.No.

C-T-102

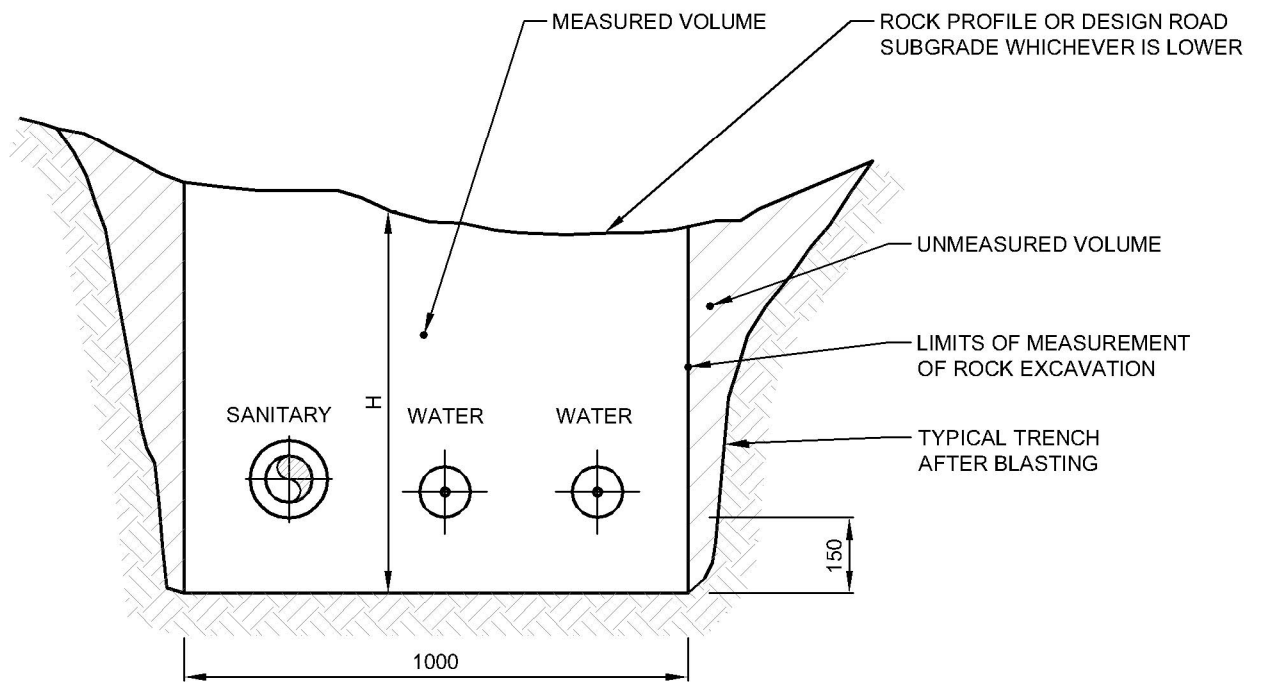

ROCK EXCAVATION QUANTITY = H x 1.00m x LENGTH OF SERVICE.

FOR REFERENCE ONLY



N.T.S.

TITLE:

TRENCH ROCK EXCAVATIONS
MEASUREMENTS - SERVICES

DATE DRAWN:
01/01/20

REVISION DATE:
06/04/2022

APPROVED BY:
YK ENG.

TRENCH

REVISION No.
1

DWG.No.

C-T-103

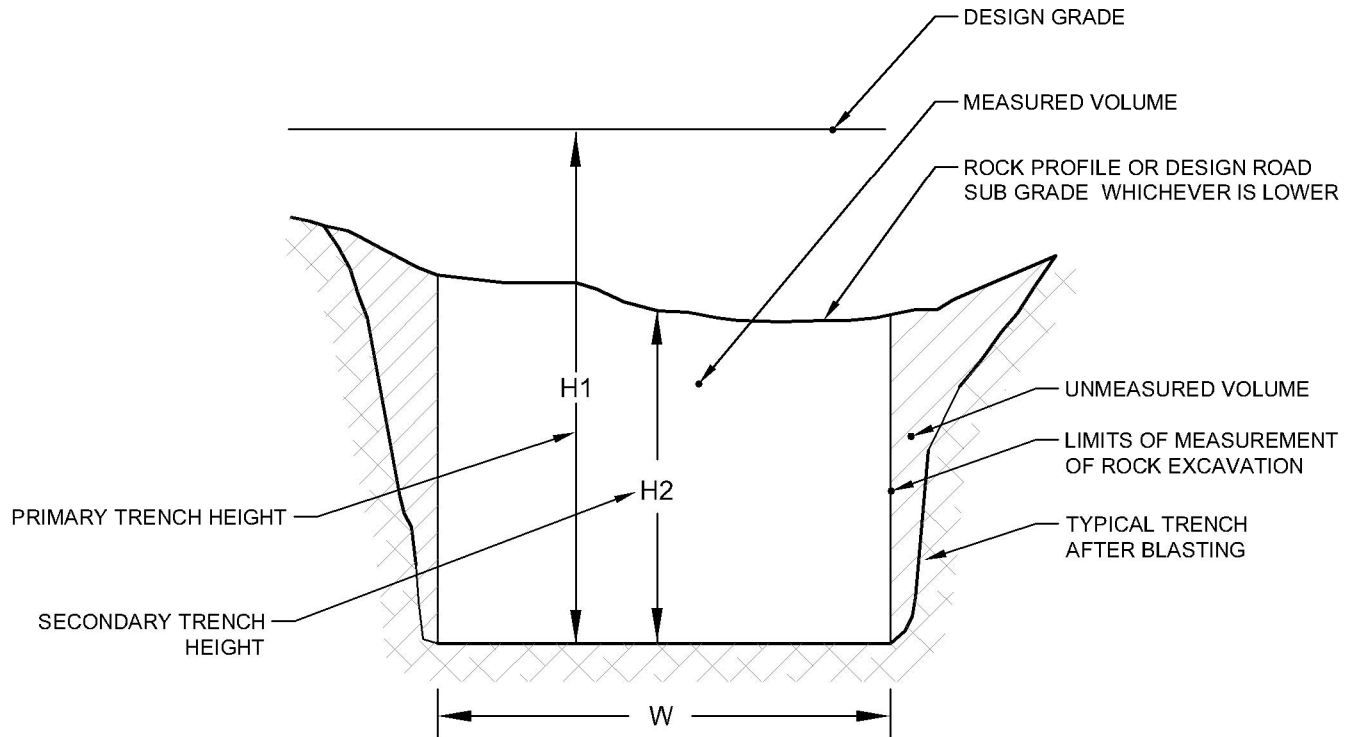

PRIMARY TRENCH
 — ROCK EXCAVATION QUANTITY = $1.00m(W) \times (H1) \times \text{LENGTH}$

SECONDARY TRENCH
 — ROCK EXCAVATION QUANTITY = $0.80m(W) \times (H2) \times \text{LENGTH}$

FOR REFERENCE ONLY



N.T.S.	
DATE DRAWN: 01/01/20	REVISION DATE: 06/04/2022
APPROVED BY: YK ENG.	

TITLE: SHALLOW UTILITY TRENCH DETAIL		
TRENCH	REVISION No. 1	DWG.No. C-T-104

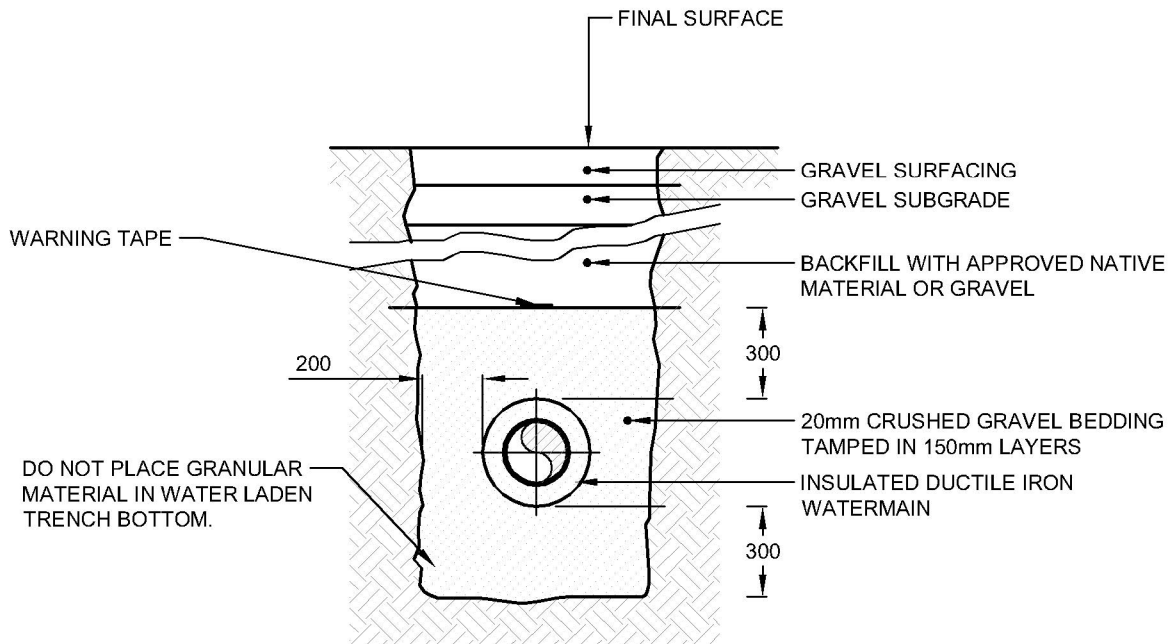

- NOTES:**
1. IN SOFT OR UNSTABLE GROUND CONDITIONS (FROZEN OR UNFROZEN), UNDERCUT SUBGRADE AS DIRECTED BY ENGINEER (SEE DWG. C-T-101).
 2. SEE DWG. C-T-101 FOR DETAIL OF COMBINED TRENCH
 3. SANITARY MAIN TO BE BEDDED USING THIS DETAIL.



1:25	
DATE DRAWN: 01/01/20	REVISION DATE: 06/04/2022
APPROVED BY: D.MCMILLAN	

TITLE:			
TYPICAL WATERMAIN BEDDING			
WATER	REVISION No. 1	DWG.No.	C-W-100

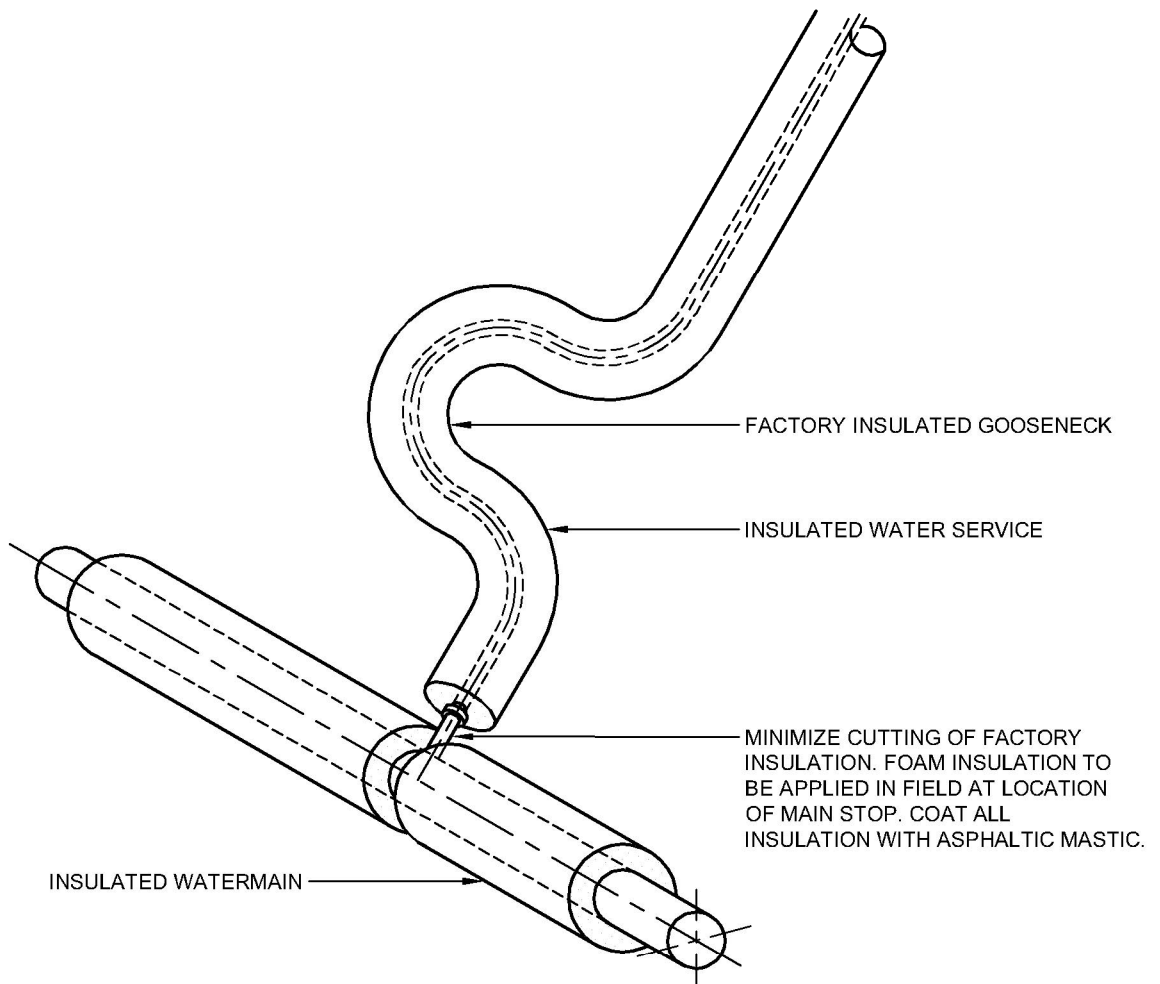

GOOSENECK / MAIN STOP INSULATION
DETAIL AT WATER MAIN SCALE N.T.S.



<p style="text-align: center;">N.T.S</p>	TITLE:		
	<p>GOOSENECK/MAIN STOP INSULATION DETAIL AT WATER MAIN</p>		
<p>DATE DRAWN: 01/01/20</p>	<p>REVISION DATE: 06/04/2022</p>	<p>WATER</p>	<p>REVISION No. 1</p>
<p>APPROVED BY: D.MCMILLAN</p>			

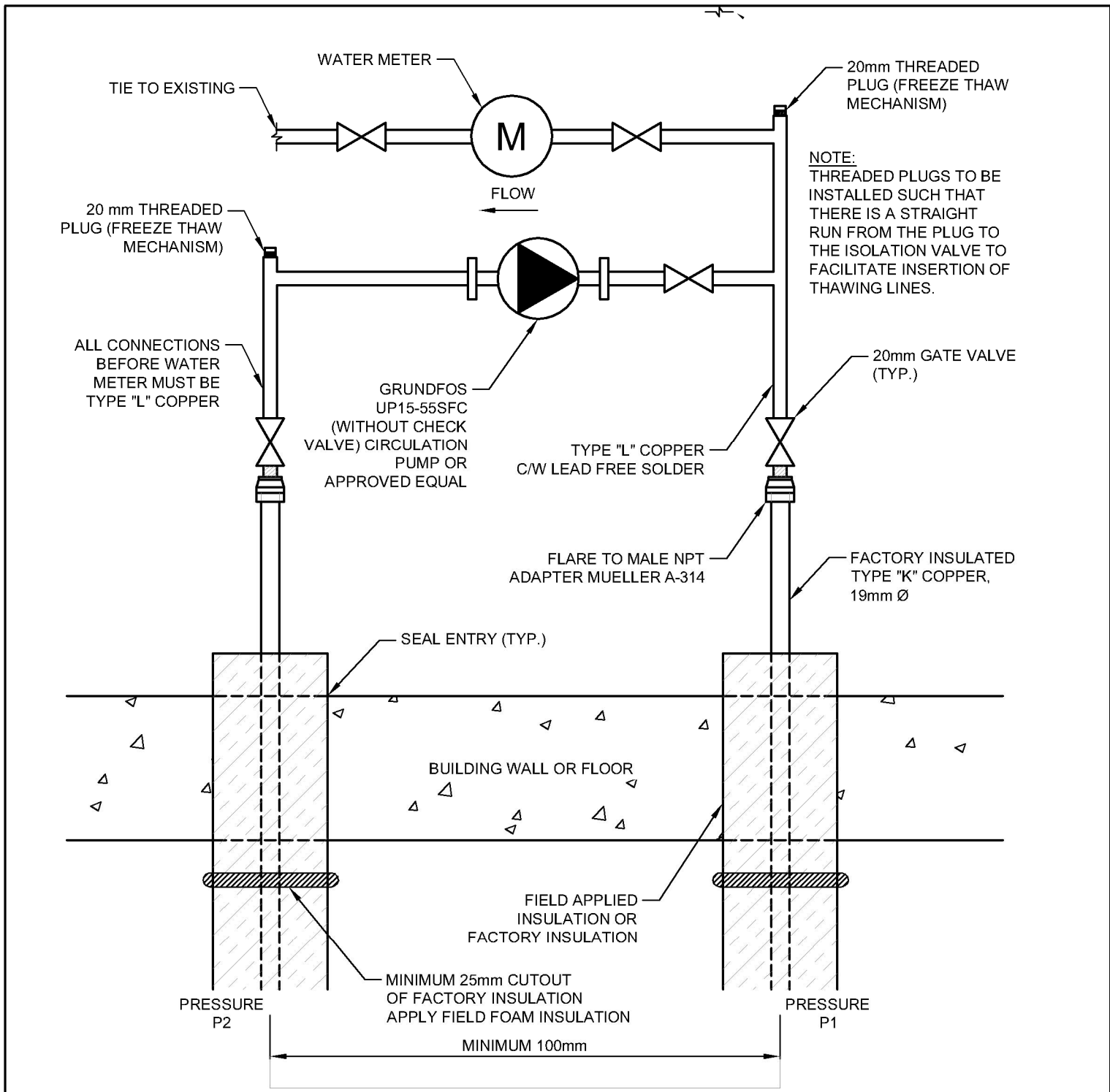

ALL FITTINGS TO BE COPPER OR BRASS, NO GALVANIZED, BLACK OR CAST IRON ALLOWED.



N.T.S.	
DATE DRAWN: 01/01/20	REVISION DATE: 06/04/2022
APPROVED BY: D.MCMILLAN	

TITLE: CIRCULATION PUMP INSTALLATION DETAIL		
WATER	REVISION No. 1	DWG.No. C-W-102

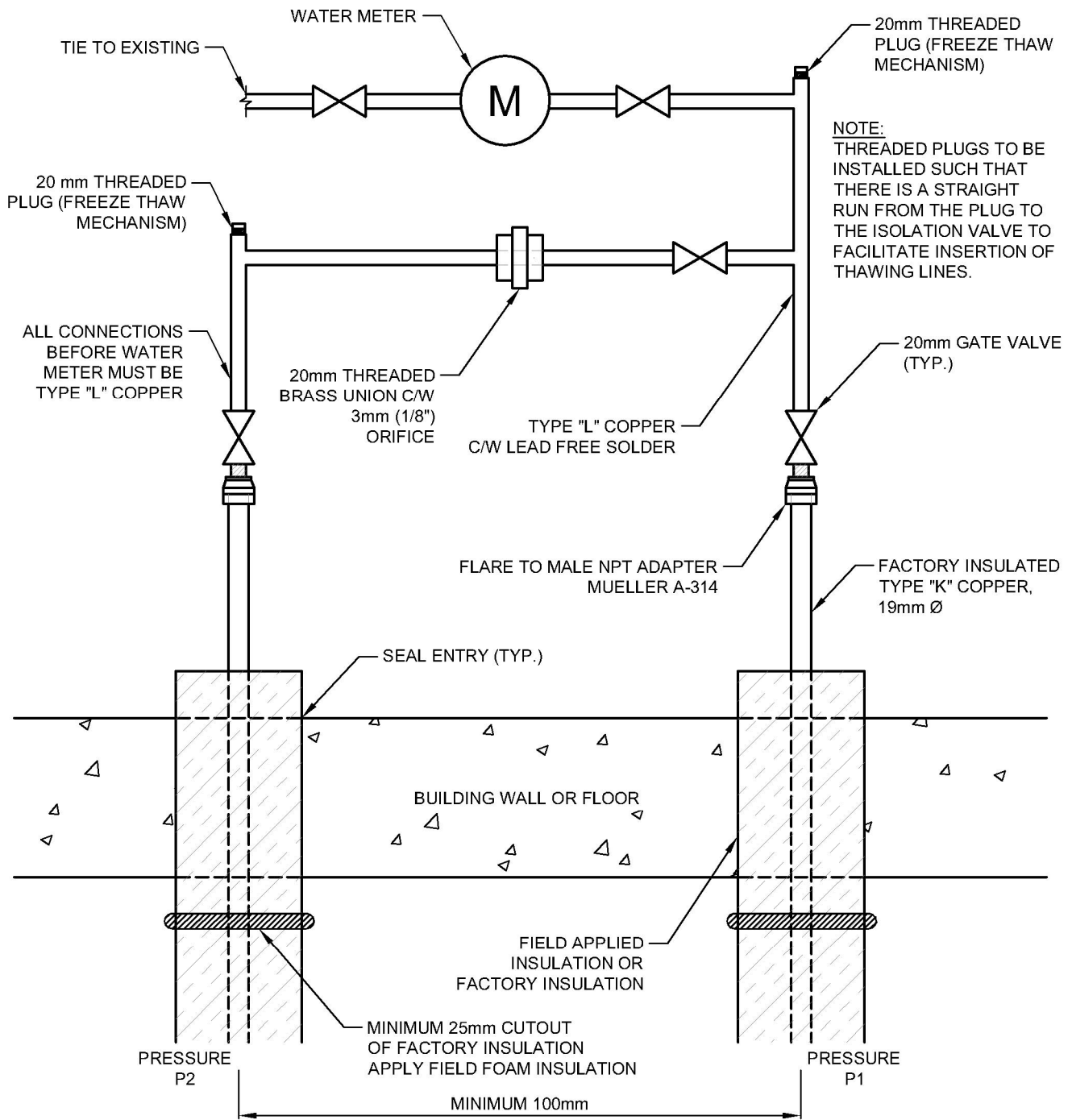

ALL FITTINGS TO BE COPPER OR BRASS, NO GALVANIZED, BLACK OR CAST IRON ALLOWED.



1:10000

TITLE:

ORIFICE INSTALLATION DETAIL

DATE DRAWN:
01/01/20

REVISION DATE:
06/04/2022

APPROVED BY:
D.MCMILLAN

WATER

REVISION No.
1

DWG.No.

C-W-103

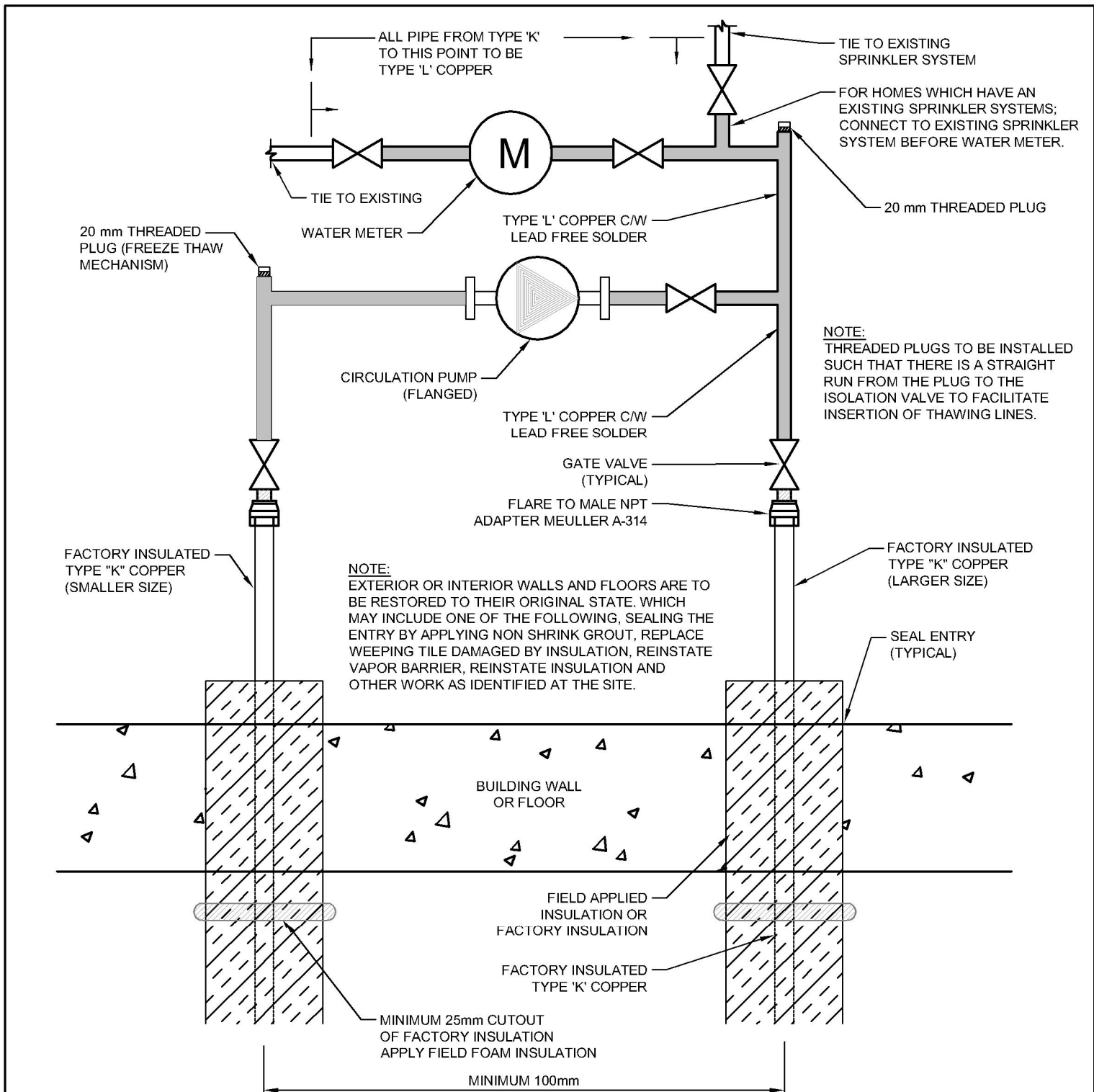

ALL FITTINGS TO BE COPPER OR BRASS, NO GALVANIZED, BLACK OR CAST IRON ALLOWED.

	N.T.S.		TITLE:		
	DATE DRAWN:	REVISION DATE:	TYPICAL BUILDING CIRCULATION PUMP & METER INSTALLATION		
	01/01/20	06/04/2022			
APPROVED BY:		WATER	REVISION No.	DWG.No.	
D.MCMILLAN			1	C-W-104	

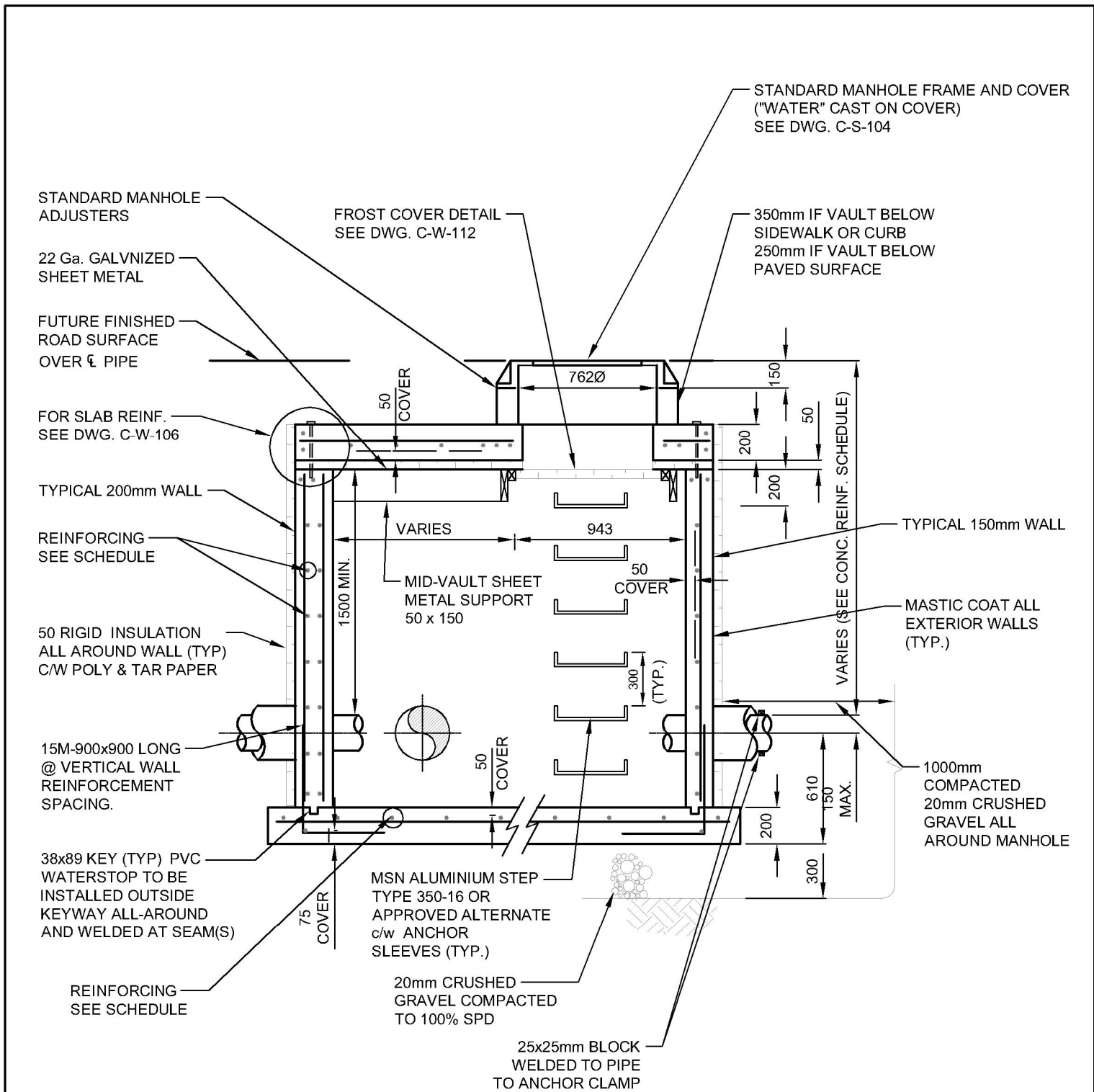

NOTES:

1. NO MANHOLE CONES TO BE USED
2. ALL UNITS ARE IN MILLIMETERS UNLESS NOTED OTHERWISE



1:30	
DATE DRAWN: 01/01/20	REVISION DATE: 06/04/2022
APPROVED BY: YK. ENG.	

TITLE: WATER MANHOLE - SECTION A	
WATER	REVISION No. 1
	DWG.No. C-W-105

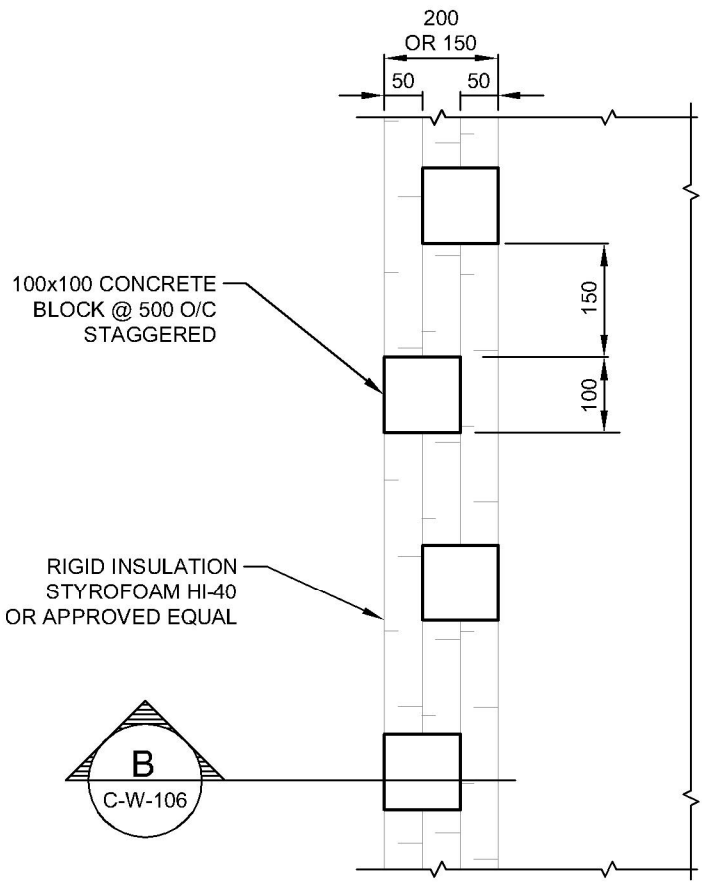

DETAIL

1
C-W-106

SCALE 1:10

PLAN

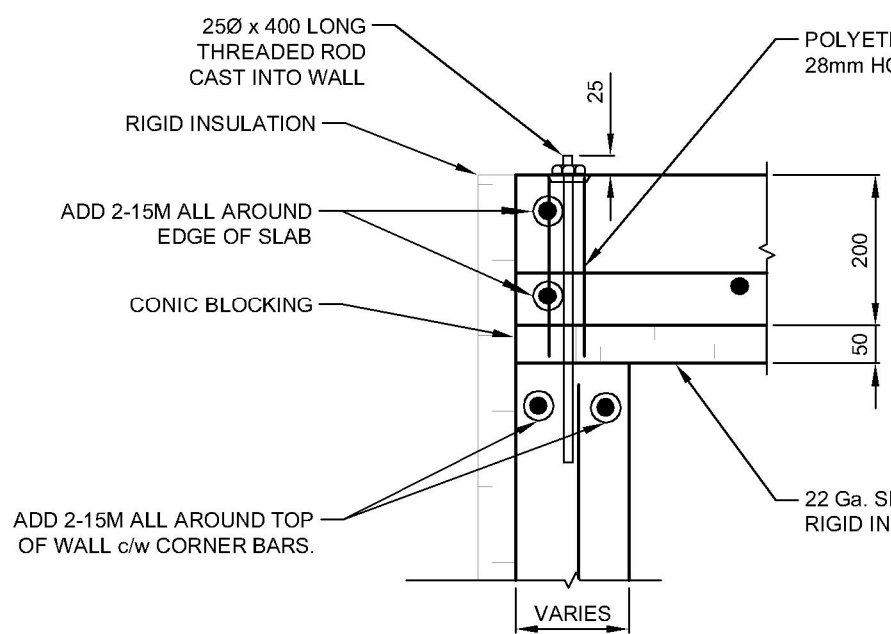

SECTION

B
C-W-106

SCALE 1:10



1:10	
DATE DRAWN: 01/01/20	REVISION DATE: 06/04/2022
APPROVED BY: YK ENG.	

TITLE: WATER MANHOLE - SLAB REINFORCEMENT		
WATER	REVISION No. 1	DWG.No. C-W-106

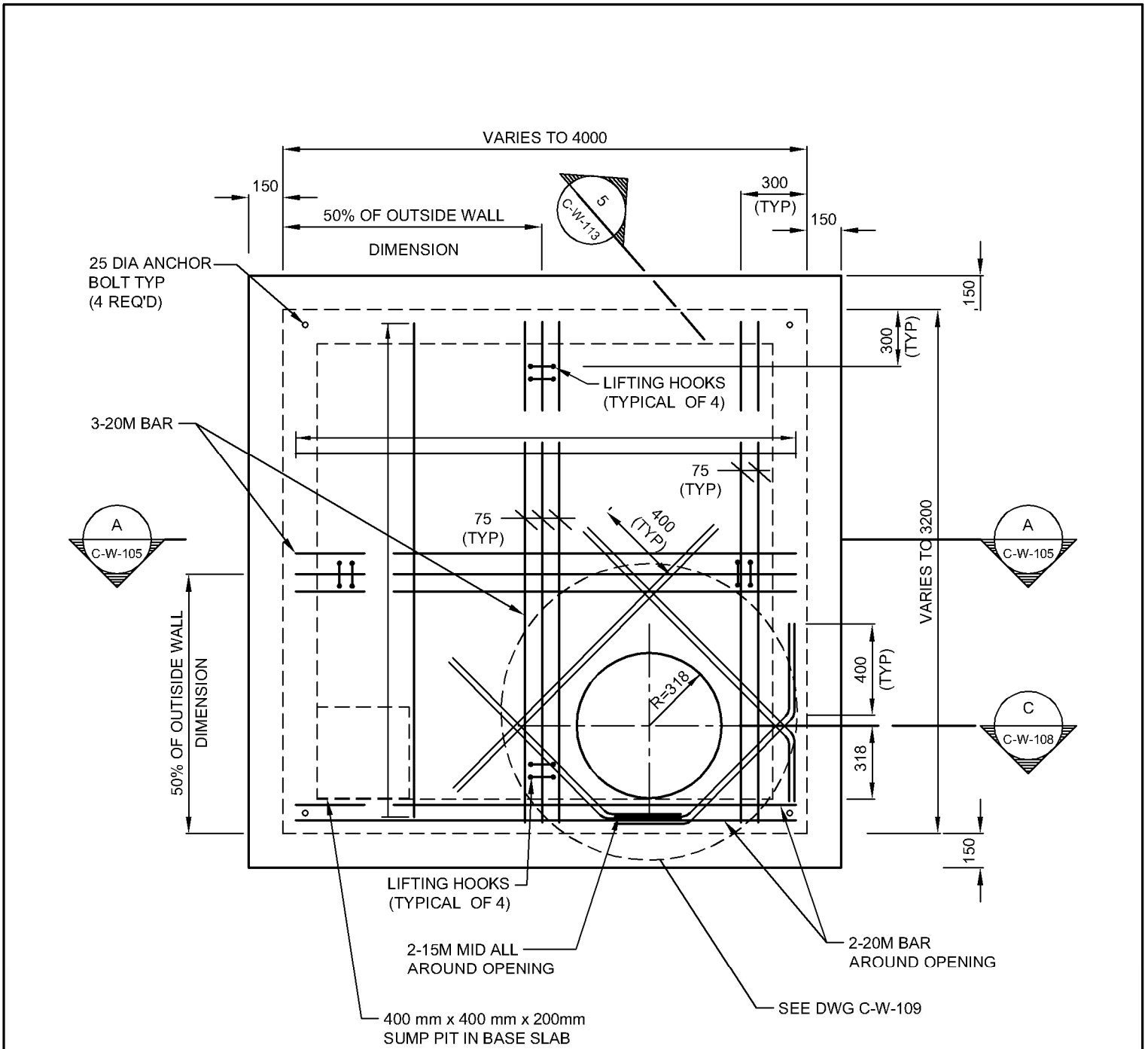

NOTE:
FOR ADDITIONAL REINFORCING SEE SCHEDULE

ALL UNITS ARE IN MILLIMETERS UNLESS NOTED OTHERWISE



1:25	
DATE DRAWN: 01/01/20	REVISION DATE: 06/04/2022
APPROVED BY: YK ENG.	

TITLE: WATER MANHOLE - ROOF SLAB PLAN		
WATER	REVISION No. 1	DWG.No. C-W-107

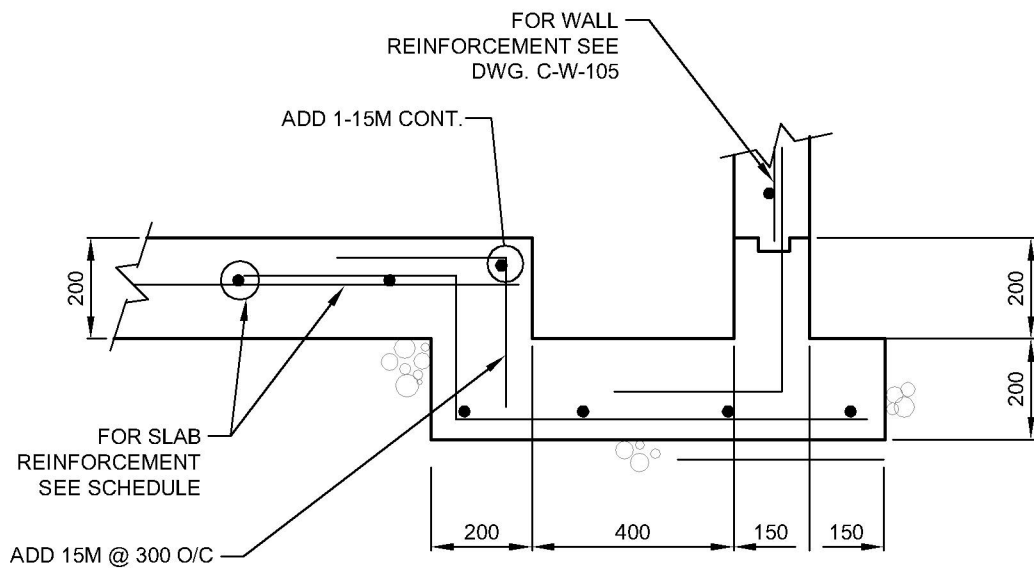

SECTION C
C-W-107



1:15	
DATE DRAWN: 01/01/20	REVISION DATE: 06/04/2022
APPROVED BY: YK ENG.	

TITLE: <b style="font-size: 1.2em;">WATER MANHOLE - SECTION C			
WATER	REVISION No. 1	DWG.No. C-W-108	

NOTE
FROST COVER HINGED AT CENTER

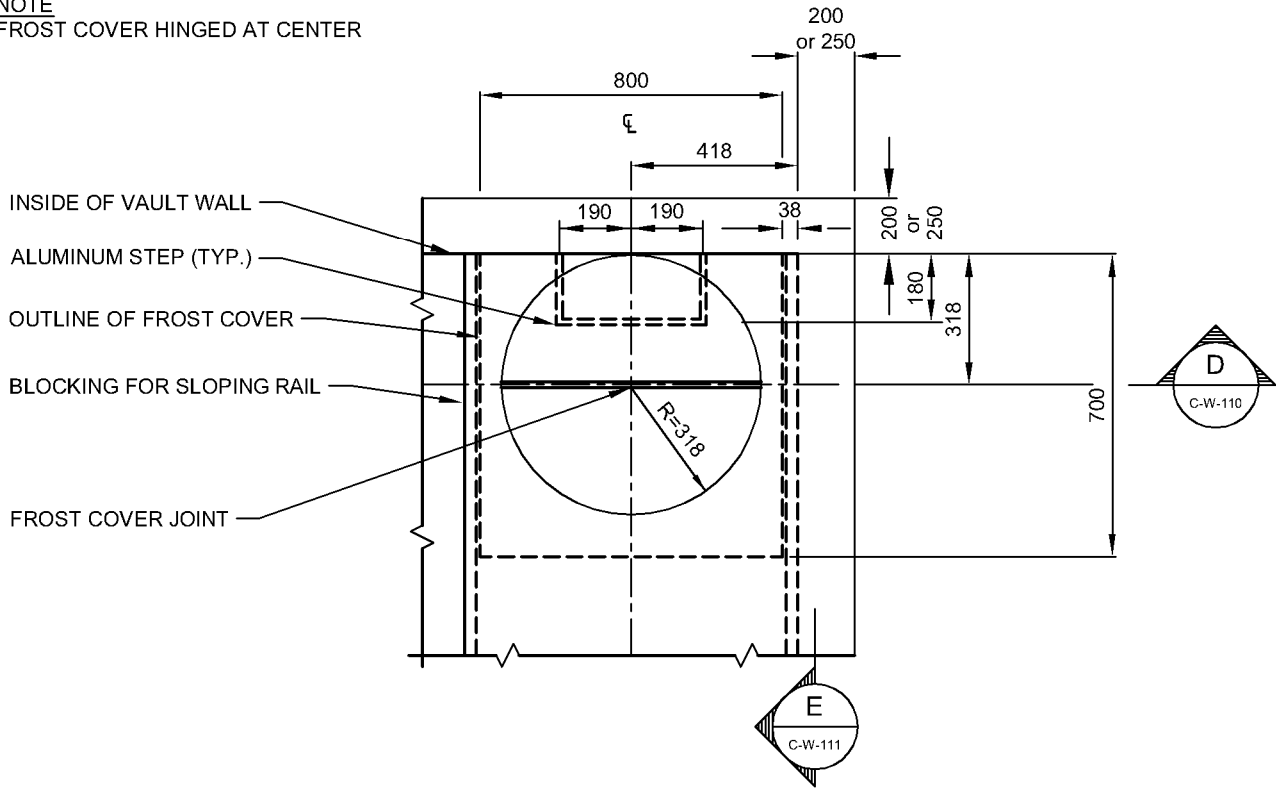

FROST COVER

ALL DIMENSIONS ARE IN MILLIMETERS UNLESS NOTED OTHERWISE



1:20

DATE DRAWN:
01/01/20

REVISION DATE:
06/04/2022

APPROVED BY:
D.MCMILLAN

TITLE:

FROST COVER PLAN

WATER

REVISION No.
1

DWG.No.

C-W-109

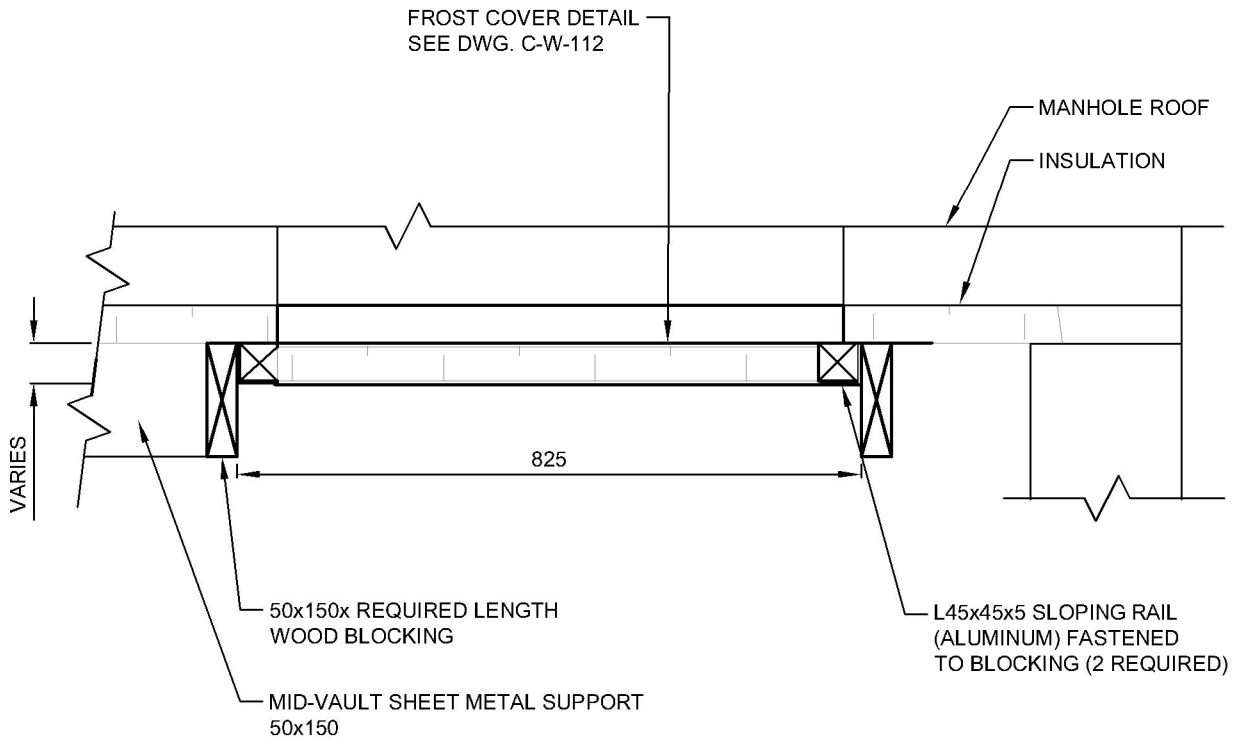

SECTION D
C-W-109



1:10	
DATE DRAWN: 01/01/20	REVISION DATE: 06/04/2022
APPROVED BY: D.MCMILLAN	

TITLE: FROST COVER - SECTION D		
WATER	REVISION No. 1	DWG.No. C-W-110

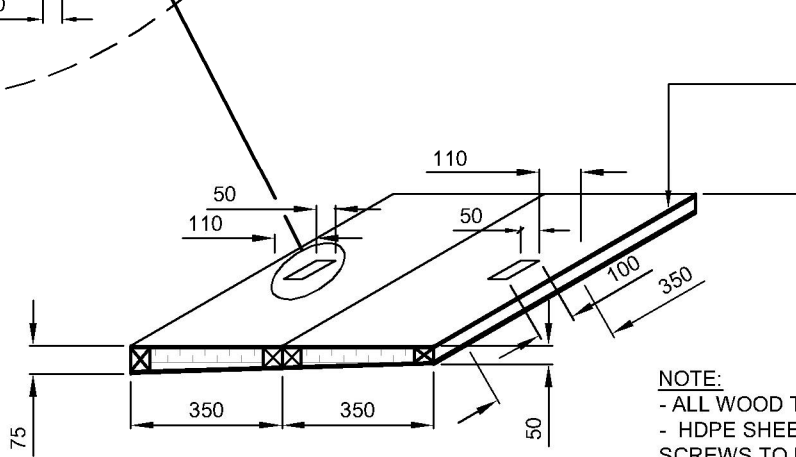
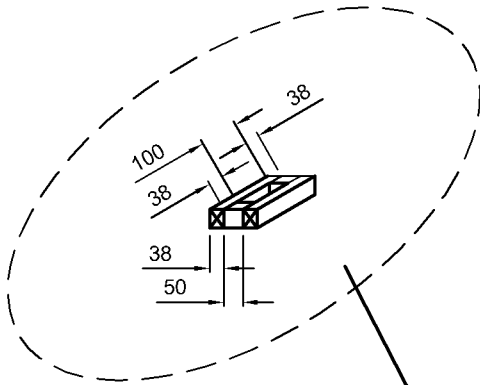

NOTE
 PLYWOOD AND HDPE SHEET TO BE CUT OUT FOR OPENING ON TOP ONLY, BOTTOM LAYERS TO REMAIN INTACT

NOTE:
 - ALL WOOD TO BE PAINTED WITH PRESERVATIVE
 - HDPE SHEET TO BE SCREWED TO WOOD, ALL SCREWS TO BE COUNTERSUNK
 - WOOD STOP TO BE FASTENED TO END OF SLOPING RAIL AFTER FROST COVER INSTALLATION

ALL DIMENSIONS ARE IN MILLIMETERS UNLESS NOTED OTHERWISE



1:20	
DATE DRAWN: 01/01/20	REVISION DATE: 06/04/2022
APPROVED BY: D.MCMILLAN	

TITLE: FROST COVER DETAIL		
WATER	REVISION No. 1	DWG.No. C-W-111

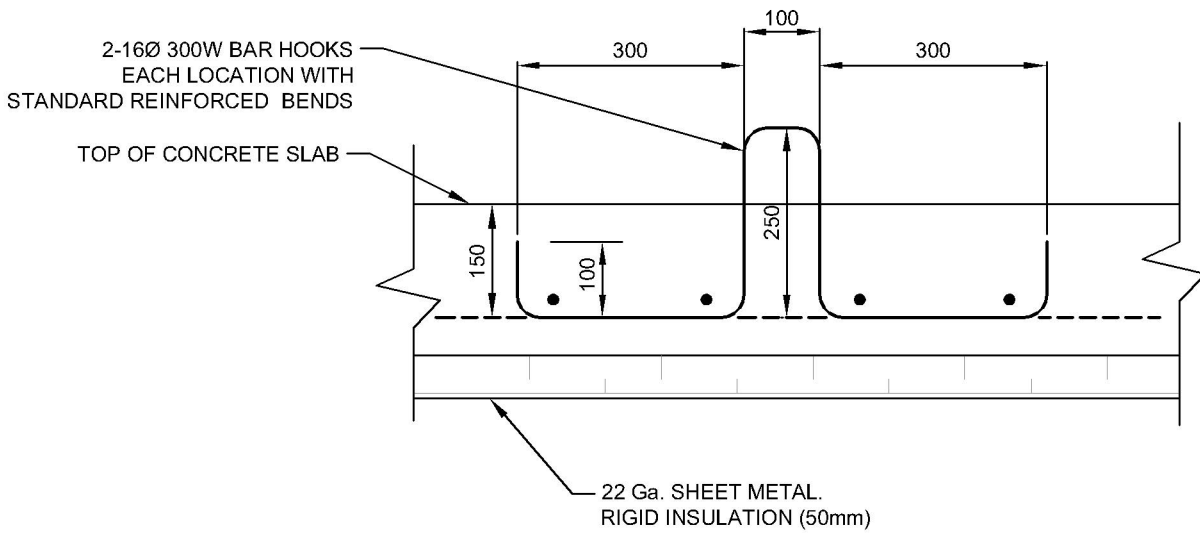

1:10

DATE DRAWN:

01/01/20

REVISION DATE:

06/04/2022

APPROVED BY:

D.MCMILLAN

TITLE:

WATER MANHOLE - LIFTING HOOKS

WATER

REVISION No.

1

DWG.No.

C-W-112

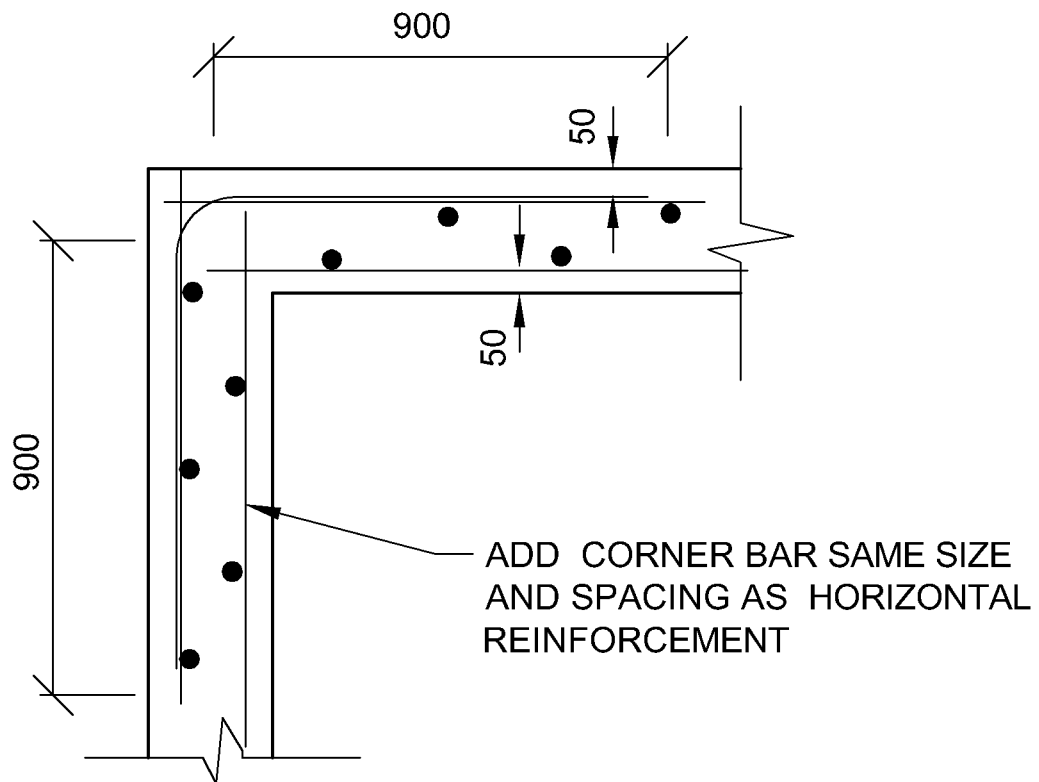

AS SHOWN

DATE DRAWN:
01/01/20

REVISION DATE:
06/04/2022

APPROVED BY:
YK ENG.

TITLE:

WATER MANHOLE - TYPICAL 200mm CORNER BAR
ENFORCEMENT

WATER

REVISION No.
1

DWG.No.

C-W-113

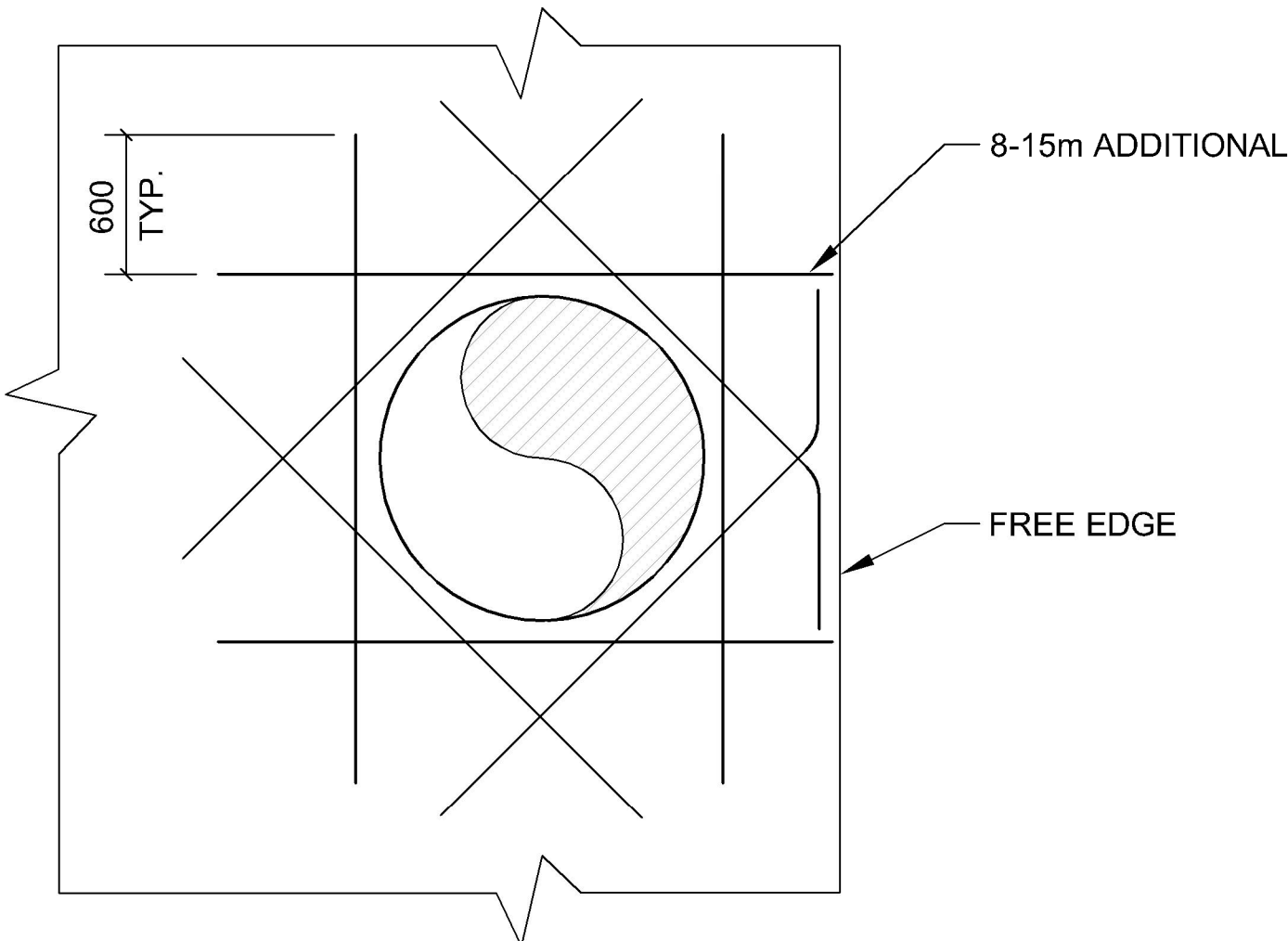

1:30	
DATE DRAWN: 01/01/20	REVISION DATE: 06/04/2022
APPROVED BY: D.MCMILLAN	

TITLE: WATER MANHOLE - TYPICAL REINFORCEMENT AROUND WALL OPENINGS		
WATER	REVISION No. 1	DWG.No. C-W-114

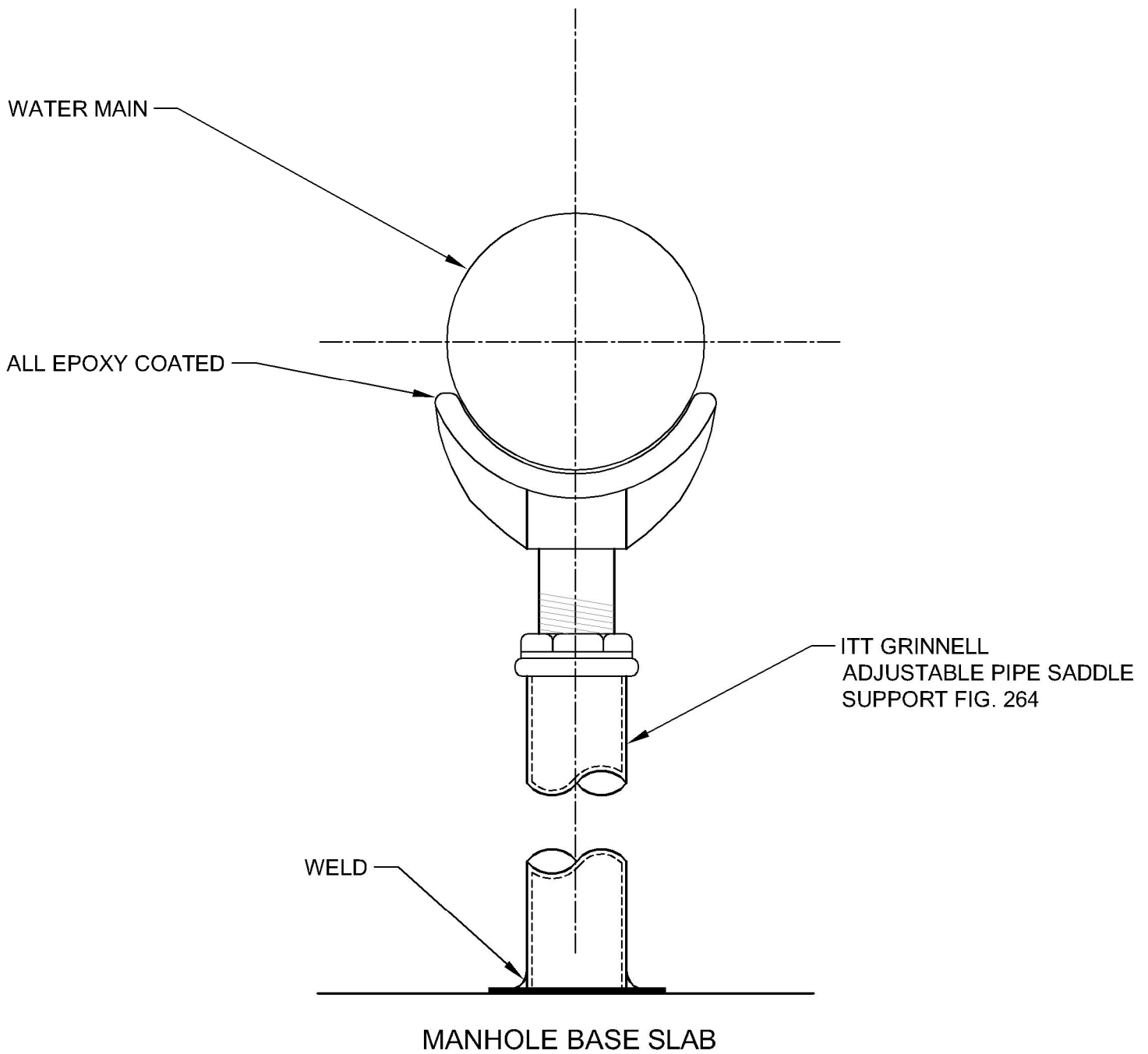

1:150

DATE DRAWN:
01/01/20

REVISION DATE:
06/04/2022

APPROVED BY:
D.MCMILLAN

TITLE:

WATER MANHOLE - PIPE SUPPORT

WATER

REVISION No.
1

DWG.No.

C-W-115

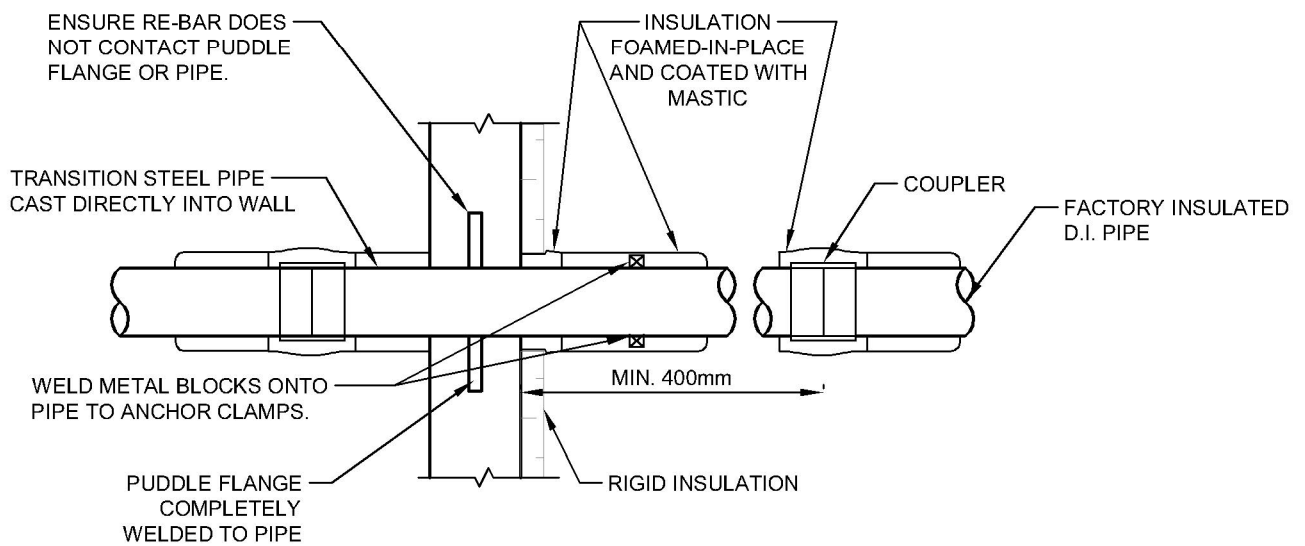

1:10

DATE DRAWN:
01/01/20

REVISION DATE:
06/04/2022

APPROVED BY:
YK ENG.

TITLE:

WATER MANHOLE - TYPICAL PIPE THOROUGH WALL

WATER

REVISION No.
1

DWG.No.

C-W-116

LIST OF COMPONENTS

(APPLIES TO ALL VALVE CHAMBERS)

- (A) — D.I. CLASS 52 (INSULATED) SIZE AS NOTED.
- (B) — ROBAR COUPLING OR BELL / SPIGOT JOINT.
- (C) — D.I. CLASS 52 (INSULATED) 1000mm LONG.
- (D) — DRAIN TAPPING (20 mm WELDOLET, BRASS NIPPLE AND GATE VALVE)
LOCATED MINIMUM 100 mm FROM INSIDE VAULT WALL
- (E) — ROBAR COUPLING (D.I. TO STEEL).
- (F) — TRANSITION STEEL, LENGTH AND SIZE TO SUIT, C/W PUDDLE FLANGE
MINIMUM LENGTH FROM OUTSIDE OF VAULT - 400 mm
- (G) — FLANGED, RESILIENT SEAT GATE VALVE, "NON-RISING STEM", SIZE AS NOTED
- (H) — FLANGED D.I. TEE.
- (J) — VIC-FLANGE ADAPTORS, STYLE 741.
- (K) — STANDARD VICTAULIC COUPLING, STYLE 77.
- (L) — 90° VICTAULIC ELBOWS, NO. 10.
- (N) — VICTAULIC CROSS
- (O) — VICTAULIC REDUCING TEE, NO. 25.
- (P) — VICTAULIC TEE, NO. 20.
- (R) — VICTAULIC CONCENTRIC REDUCER, NO. 50.
- (S) — VICTAULIC GROOVED NIPPLE, NO. 43 OR AS REQUIRED.
- (T) — D.I. REDUCER
- (U) — D.I. FLANGED CROSS
- (V) — VENT TAPPING (20mm WELDOLET, BRASS NIPPLE AND GATE VALVE) (SEE NOTES)
- (W) — FLANGED D.I. HYDRANT TEE (MAIN SIZE x 150mmØ), HYD. RISER AND HYD.
- (Y) — 12mm THICK METAL BLOCKS WELDED TO F, FOUR (4) PER TRANSITION STEEL
- (Z) — VICTAULIC CAP

NOTES:

1. INSTALL BOTH DRAIN "D" AND VENT "V" TAPPING ON EACH TRANSITION STEEL "F"
2. LOCATION OF MANHOLE TO BE DETERMINED BY ENGINEER (APPLIES TO ALL VAULTS)
3. IF CONTRACTOR USING HYDRANTS FROM STOCK, "W" MUST BE MAIN SIZE X 200 mm Ø.
4. ALL COMPONENTS TO BE EPOXY COATED BY MANUFACTURER. FIELD APPLICATIONS OF EPOXY COATINGS WILL NOT BE ACCEPTED. BURN MARKS FROM WELDING WILL RESULT IN IMMEDIATE REFUSAL FOR ACCEPTANCE.



N.T.S.

DATE DRAWN: 01/01/20	REVISION DATE: 06/04/2022
-------------------------	------------------------------

APPROVED BY:
YK ENG.

TITLE:

LIST OF COMPONENTS

WATER

REVISION No.
1

DWG.No.

C-W-117

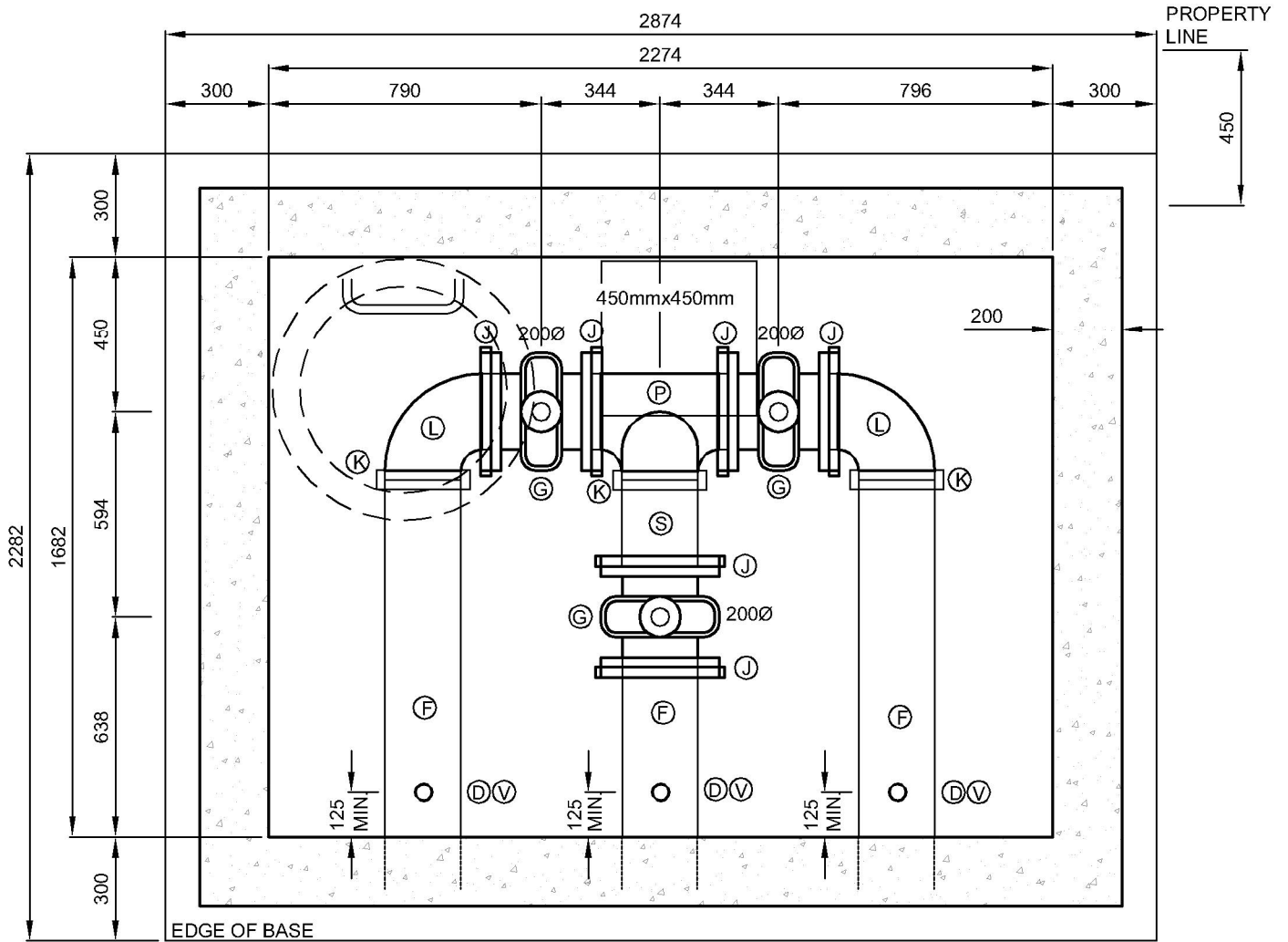

COMPONENTS - REFER TO LIST OF COMPONENTS

COMPONENTS - REFER TO LIST OF COMPONENTS DETAIL



1:20

TITLE:

WATER VAULT - 200mm Ø MAIN (AV1)

DATE DRAWN:

01/01/20

REVISION DATE:

06/04/2022

APPROVED BY:

D.MCMILLAN

WATER

REVISION No.

1

DWG.No.

C-W-118

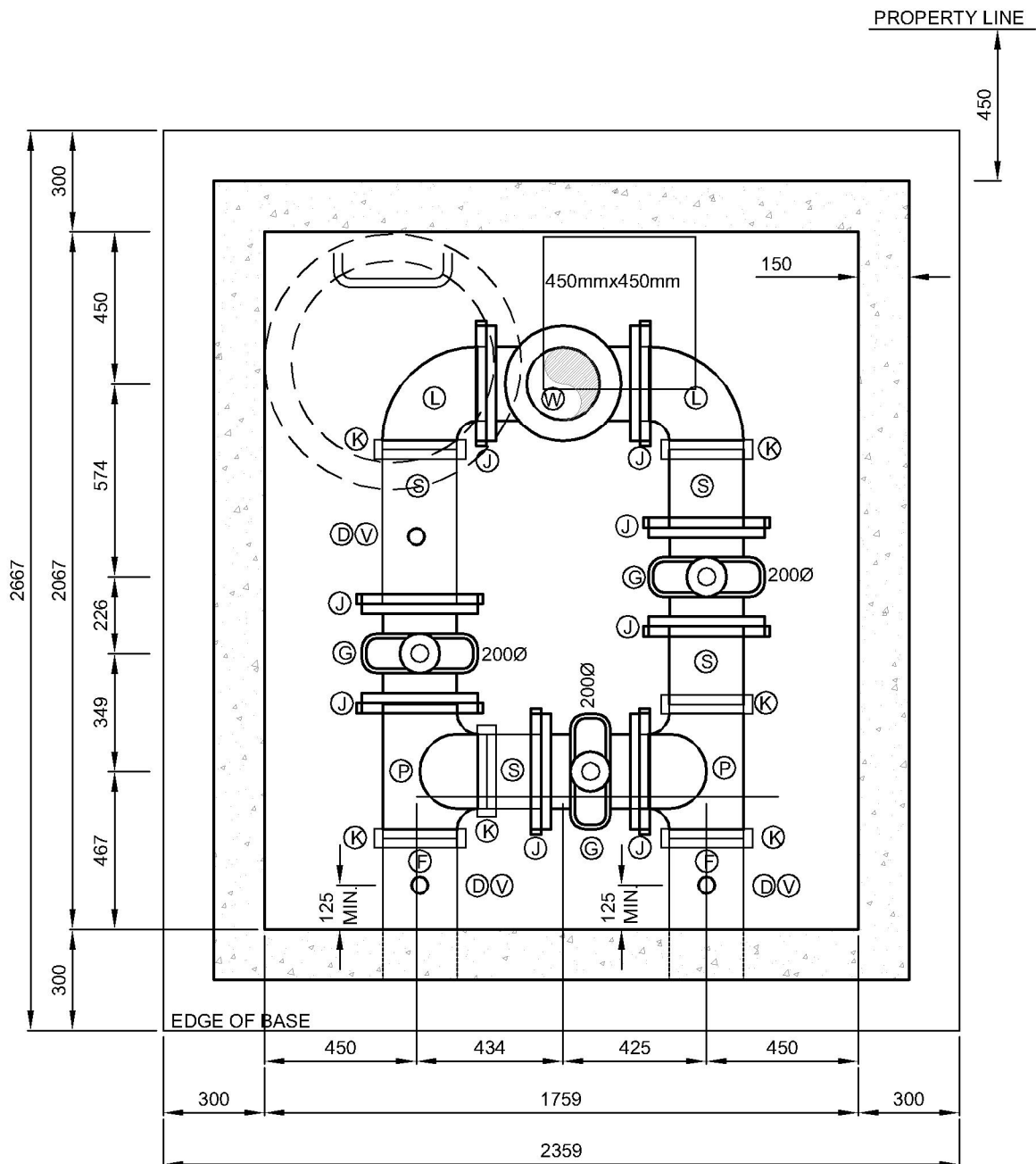

COMPONENTS - REFER TO LIST OF COMPONENTS



1:20

TITLE:

WATER VAULT - 200mm Ø MAIN (HV2)

DATE DRAWN:

01/01/20

REVISION DATE:

06/04/2022

APPROVED BY:

D.MCMILLAN

WATER

REVISION No.

1

DWG.No.

C-W-119

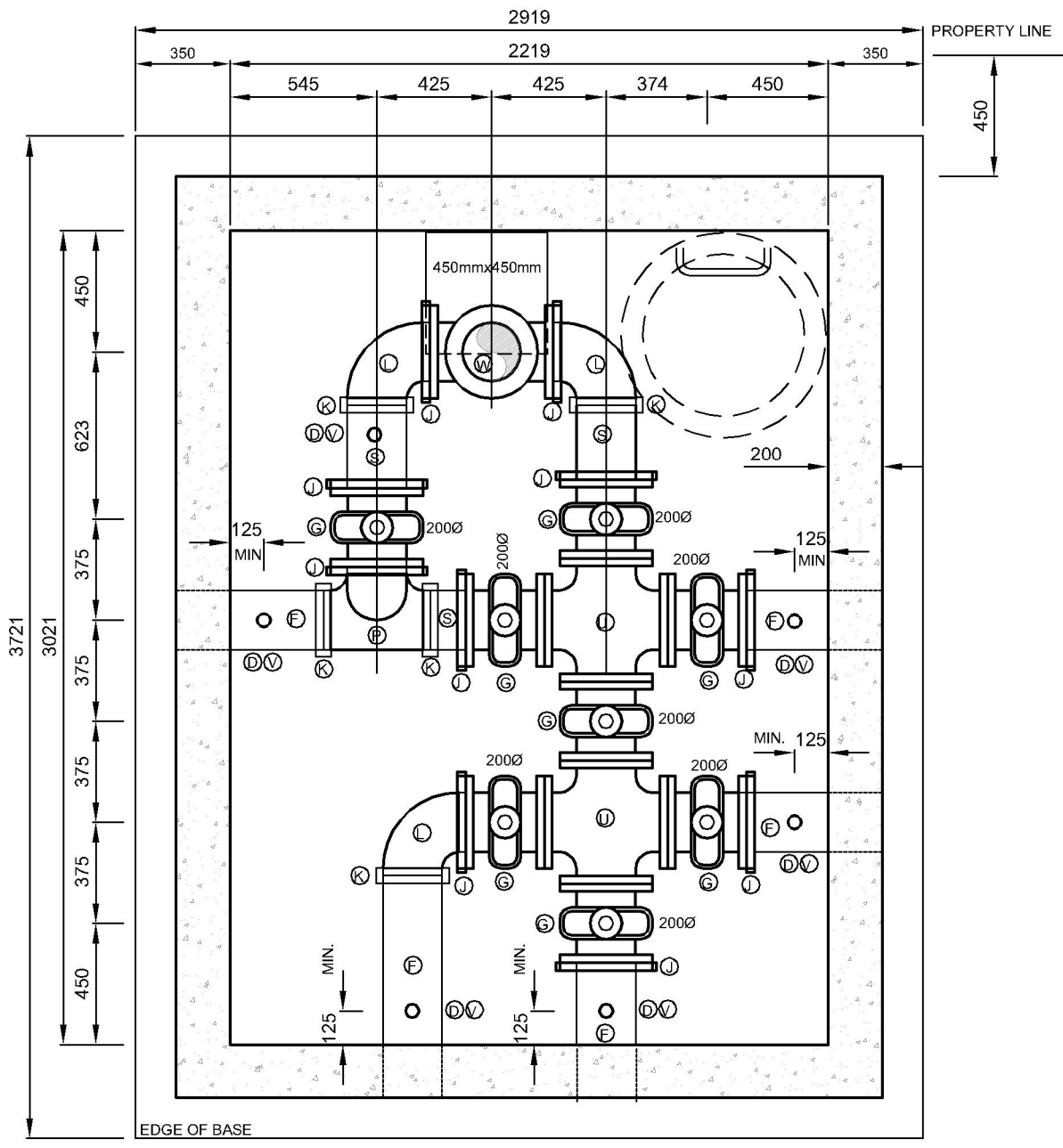

ALL DIMENSIONS IN MILLIMETERS UNLESS NOTED OTHERWISE



1:25	
DATE DRAWN: 01/01/20	REVISION DATE: 06/04/2022
APPROVED BY: D.MCMILLAN	

TITLE: WATER VAULT - 200mm Ø MAIN (HV3)	
WATER	REVISION No. 1
	DWG.No. C-W-120

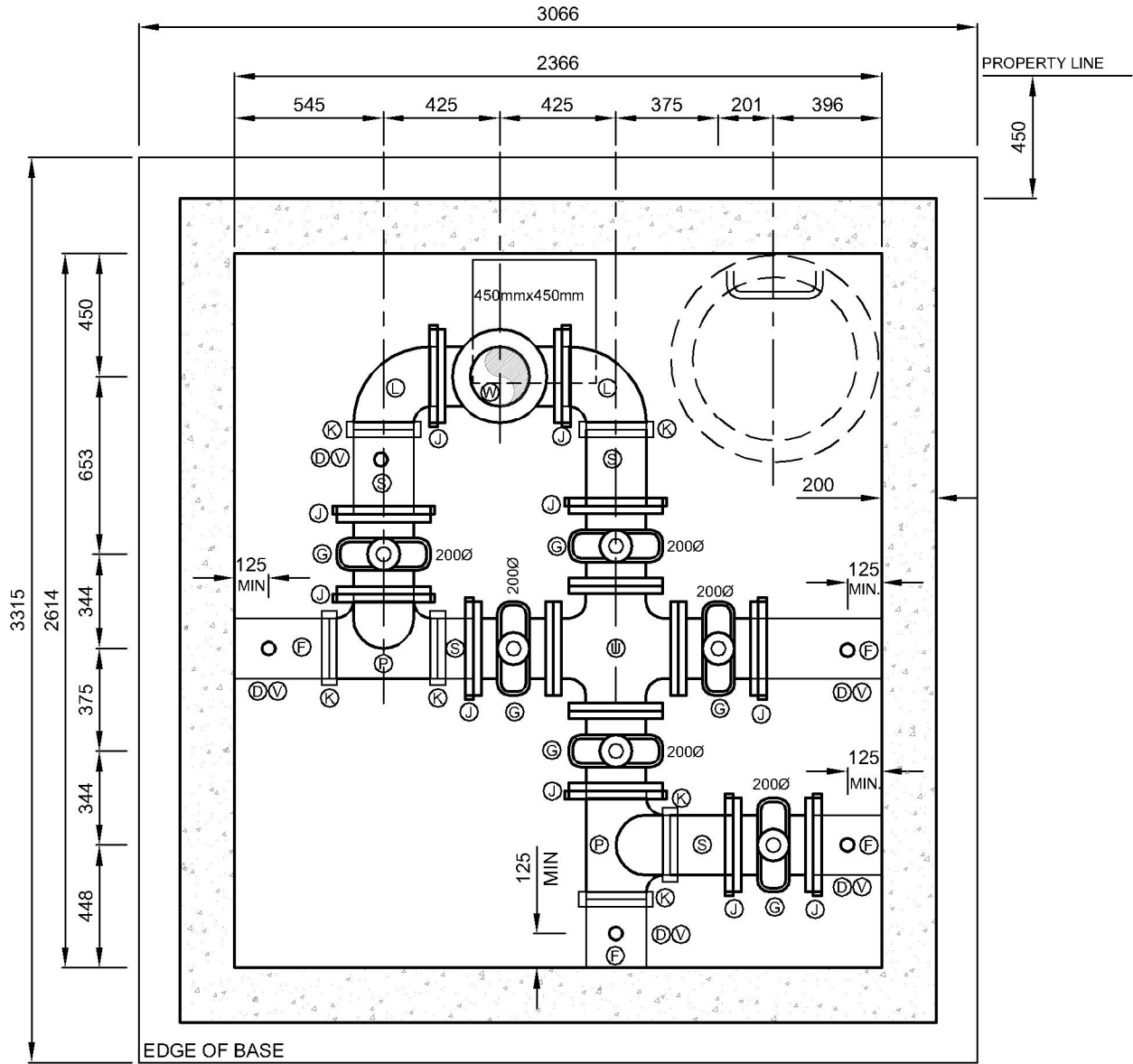

COMPONENTS - REFER TO LIST OF COMPONENTS

ALL DIMENSIONS ARE IN MILLIMETERS UNLESS NOTED OTHERWISE



1:25	
DATE DRAWN: 01/01/20	REVISION DATE: 06/04/2022
APPROVED BY: D.MCMILLAN	

TITLE: WATER VAULT - 200mm Ø (HV4)	
WATER	REVISION No. 1
	DWG.No. C-W-121

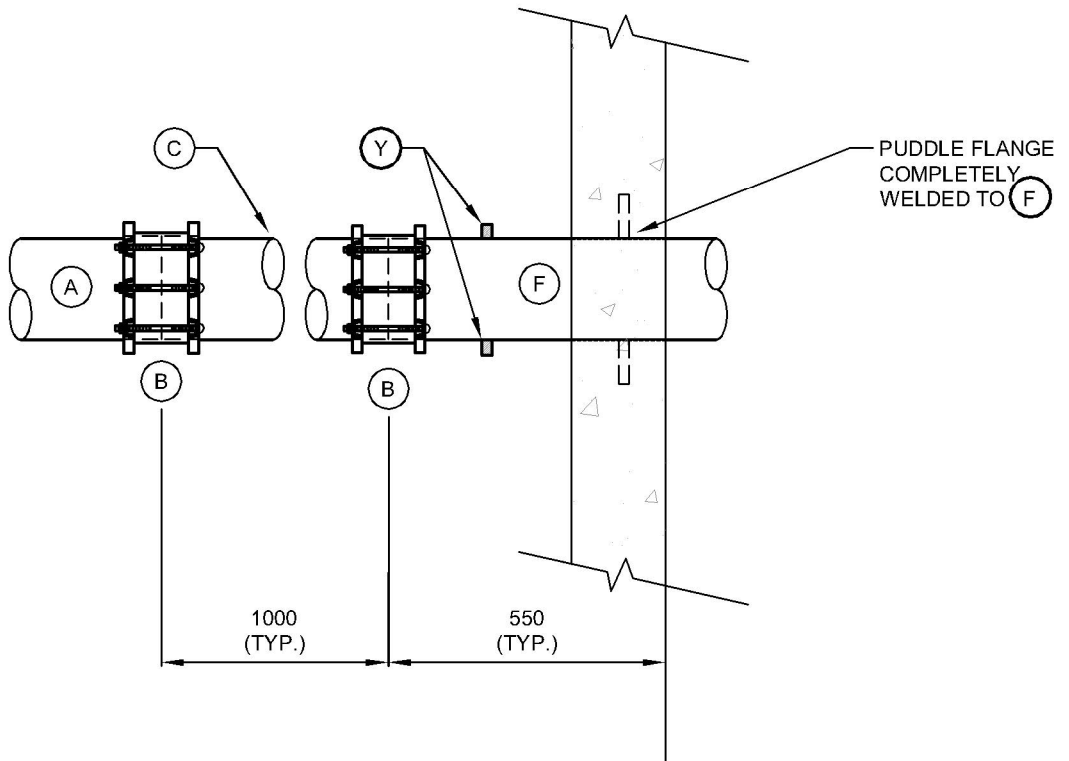

COMPONENTS - REFER TO LIST OF COMPONENTS



1:15	
DATE DRAWN: 01/01/20	REVISION DATE: 06/04/2022
APPROVED BY: YK ENG.	

TITLE: DETAIL CONNECTION TO MH. WALL		
WATER	REVISION No. 1	DWG.No. C-W-122

CLAMPING TABLE - 300 mm DIA AND SMALLER

FITTING TYPE	MINIMUM CLAMPED LENGTH (metres)	JOINTS NORMALLY CLAMPED *
TEE - RUN	24	4
TEE - BRANCH	24	4
DEAD END	24	4
90 ° BEND	24	4
45 ° BEND	12	2
22 1/2 ° BEND	6	1
11 1/4 ° BEND	6	1
REDUCER	ENGINEER TO DEFINE	---

*PARTIAL LENGTH ON EACH SIDE OF FITTING

NOMINAL PIPE SIZE	TIE ROD DIAMETER
100 mm	16 mm
150 mm	19 mm
200 mm	19 mm
250 mm	22 mm
300 mm	22 mm

NOTES:

1. PROTECT CLAMPS WITH FACTORY APPLIED TWO PART EPOXY COATING TO AWWA C210-84
2. USE UNI-FLANGE 1390-C, OR APPROVED ALTERNATIVE.
3. CLAMP EACH INDIVIDUAL JOINT.
4. INSULATE FITTINGS AND REPAIR INSULATION CUTBACKS AS PER BELL AND SPIGOT JOINTS.
5. TIE RODS, NUTS, BOLTS AND WASHERS TO BE TYPE 304 STAINLESS STEEL.
6. WASHERS MUST BE USED UNDER ALL NUTS TO PREVENT DAMAGE TO EPOXY COATING.
7. TEFLON WASHERS, OR EQUIVALENT, ARE TO BE INSTALLED BETWEEN ALL WASHERS AND CLAMPS.



N.T.S.

DATE DRAWN: 01/01/20	REVISION DATE: 06/04/2022
-------------------------	------------------------------

APPROVED BY:
YK ENG.

TITLE:

UNDERGROUND PIPE CLAMPS DETAIL

WATER

REVISION No.
1

DWG.No.

C-W-123

FACTORY INSULATION CUT BACK FOR ATTACHING CLAMPS. COAT EXPOSED INSULATION WITH WATER PROOFING SEALANT

FIELD APPLIED FOAM INSULATION TO COVER ALL CLAMPS, TIE RODS, NUTS AND BOLTS TO MINIMUM 50 mm THICKNESS. TRIM EXCESS INSULATION TO SMOOTH CONTOUR AROUND JOINT PRIOR TO APPLICATION OF WATER PROOFING SEALANT

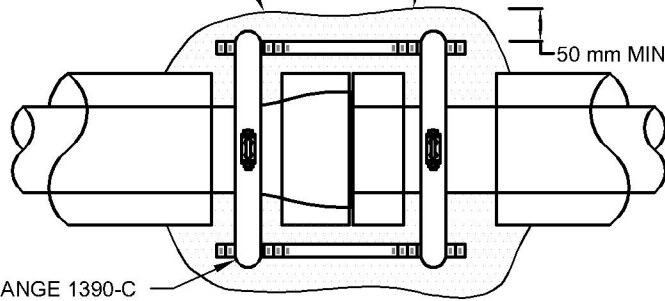

INSULATED PIPE CLAMPING - TOP

UNI-FLANGE 1390-C

TRIM EXCESS FIELD APPLIED INSULATION TO SMOOTH CONTOUR AROUND JOINT

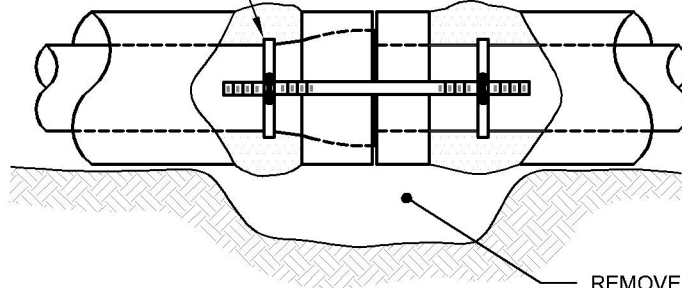

REMOVE PIPE BEDDING TO SUFFICIENT DEPTH TO ALLOW APPLICATION OF FOAM INSULATION AND WATER PROOFING SEALANT REPLACE AND HAND TAMP BEDDING MATERIAL

INSULATED PIPE CLAMPING - SIDE



1:15

TITLE:

INSULATED PIPE CLAMPING (TOP AND SIDE)

DATE DRAWN:
01/01/20

REVISION DATE:
06/04/2022

APPROVED BY:
D.MCMILLAN

WATER

REVISION No.
1

DWG.No.

C-W-124

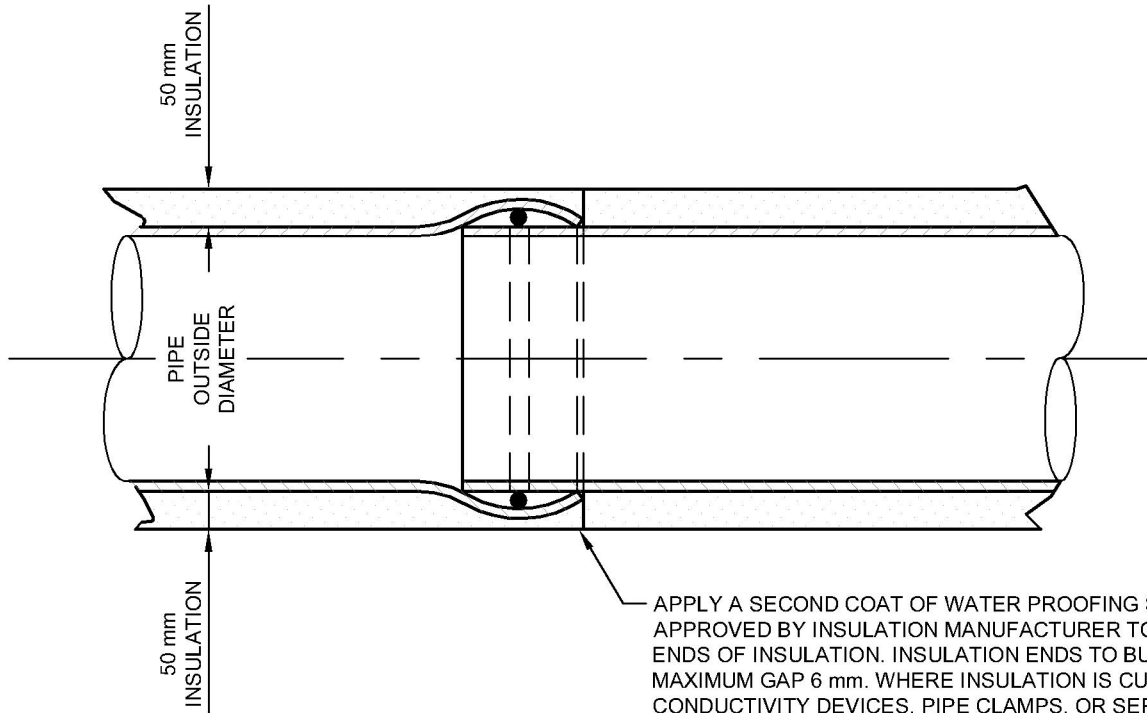

APPLY A SECOND COAT OF WATER PROOFING SEALANT APPROVED BY INSULATION MANUFACTURER TO EXPOSED ENDS OF INSULATION. INSULATION ENDS TO BUTT MAXIMUM GAP 6 mm. WHERE INSULATION IS CUT BACK FOR CONDUCTIVITY DEVICES, PIPE CLAMPS, OR SERVICE CONNECTIONS, REPAIR WITH FIELD APPLIED FOAM AND COVER WITH APPROVED WATER PROOFING SEALANT.



1:10	
DATE DRAWN: 01/01/20	REVISION DATE: 06/04/2022
APPROVED BY: YK ENG.	

TITLE: INSULATED WATERMAINS - BELL AND SPIGOT JOINT		
WATER	REVISION No. 1	DWG.No. C-W-125

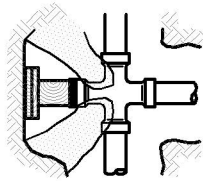

①

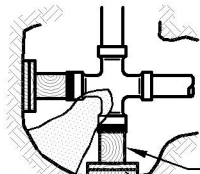

②

100mm x 100mm
WOOD BLOCK (TYP.)
2-50mm x 200mm x 250mm
WOOD THRUST BLOCKING
(TYP.)

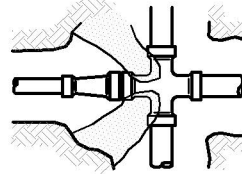

③

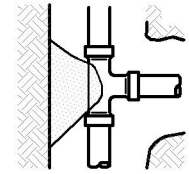

④

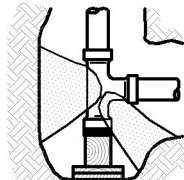

⑤

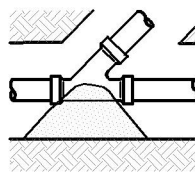

⑥

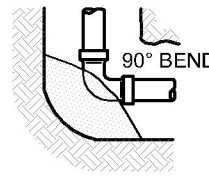

⑦

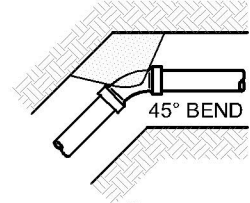

⑧

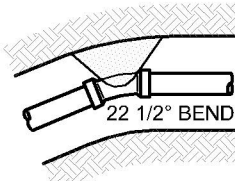

⑨

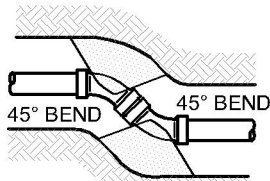

⑩

IF DEAD END FINAL
USE CONCRETE
THRUST BLOCKING.

FOR FUTURE EXTENSION
USE WOOD THRUST
BLOCKING.

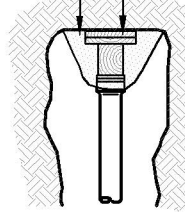

⑪

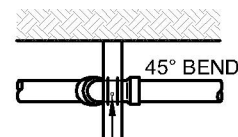

#15 REBAR (TYP.)

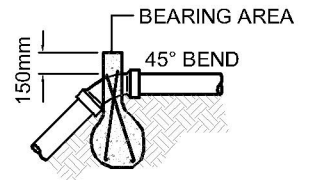

⑫

REACTION BLOCKING

REACTION BLOCKING - BEARING AREA													
AREA IN m ²							AREA IN m ²						
TYPE	PIPE SIZE (mm)						TYPE	PIPE SIZE (mm)					
	100	150	200	250	300	400		100	150	200	250	300	400
1/4/12	0.20	0.40	0.65	1.10	1.45	2.60	9	0.10	0.15	0.30	0.45	0.60	1.10
2/5/7	0.30	0.55	0.90	1.45	2.10	3.70	10	0.30	0.60	1.00	1.20	2.20	4.20
3	0.10	0.15	0.20	0.35	0.50	0.85							
6/8/11	0.15	0.30	0.60	0.60	1.20	2.00							

NOTES:

- THRUST BLOCK AREAS BASED ON 75 kPa HORIZONTAL LOADING
- CONCRETE TO BE 15 MPa AT 28 DAYS
- ALL BLOCKING TO BE AGAINST UNDISTURBED GROUND
- WOOD BLOCKING TO BE AGAINST UNDISTURBED GROUND
- 2 LAYERS OF 6 mil (0.15mm) POLYETHYLENE TO BE PLACED BETWEEN PIPE AND CONCRETE
- INSULATED PIPE/FITTING: REMOVE INSULATION WHERE CONCRETE THRUST BLOCKING BEARS AGAINST PIPE. REMAINING EXPOSED PIPE NOT IN CONTACT WITH THRUST BLOCK TO BE RE-INSULATED AND SEALED



N.T.S.

DATE DRAWN:
01/01/20

REVISION DATE:
06/04/2022

APPROVED BY:
YK ENG.

TITLE:

REACTION BLOCKING A

WATER

REVISION No.
1

DWG.No.

C-W-126

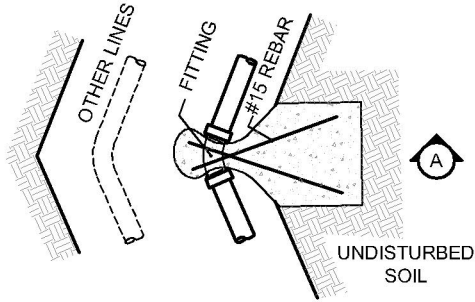

DEADMAN THRUST BLOCK

HEIGHT SUFFICIENT TO PROVIDE REQUIRED AREA (SEE REACTION BLOCKING)

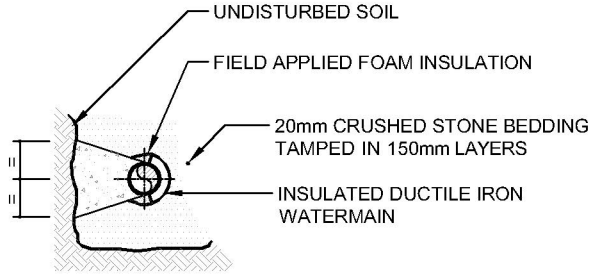

TYPICAL REACTION BLOCK SIDE VIEW

ALTERNATIVE:
CROSSING OTHER LINE TO OPPOSITE TRENCH WALL IF DIRECTED BY ENGINEER

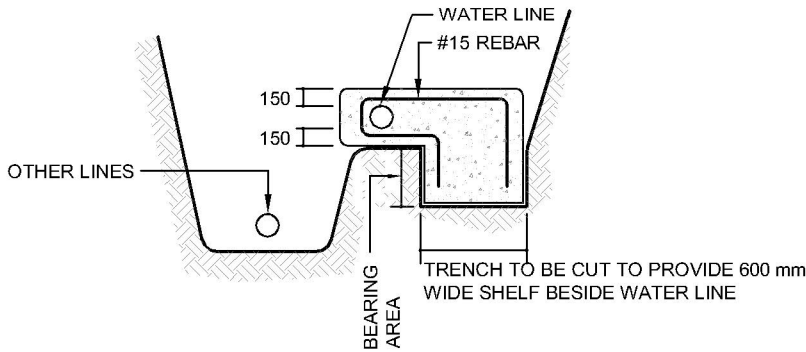

SECTION A

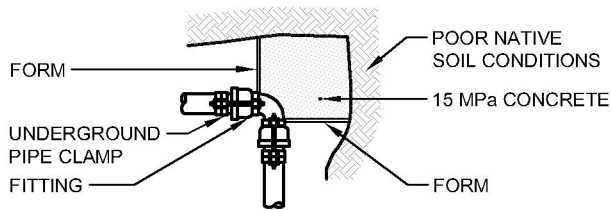

NOTES:

1. TO BE USED ONLY IN POOR NATIVE SOIL CONDITIONS, WHERE DIRECTED BY THE ENGINEER.
2. ENSURE THAT FITTING IS ACCESSIBLE, i.e. NOT COVERED BY CONCRETE
3. VOLUME OF REACTION BLOCK:
 - 3.1.1. 150mmØ - 1.4 CUBIC METERS
 - 3.1.2. 200mmØ - 1.4 CUBIC METERS
 - 3.1.3. 250mmØ - 2.2 CUBIC METERS

ALTERNATE REACTION BLOCKING



N.T.S.

TITLE:

REACTION BLOCKING B

DATE DRAWN:

01/01/20

REVISION DATE:

06/04/2022

APPROVED BY:

YK ENG.

WATER

REVISION No.

1

DWG.No.

C-W-127

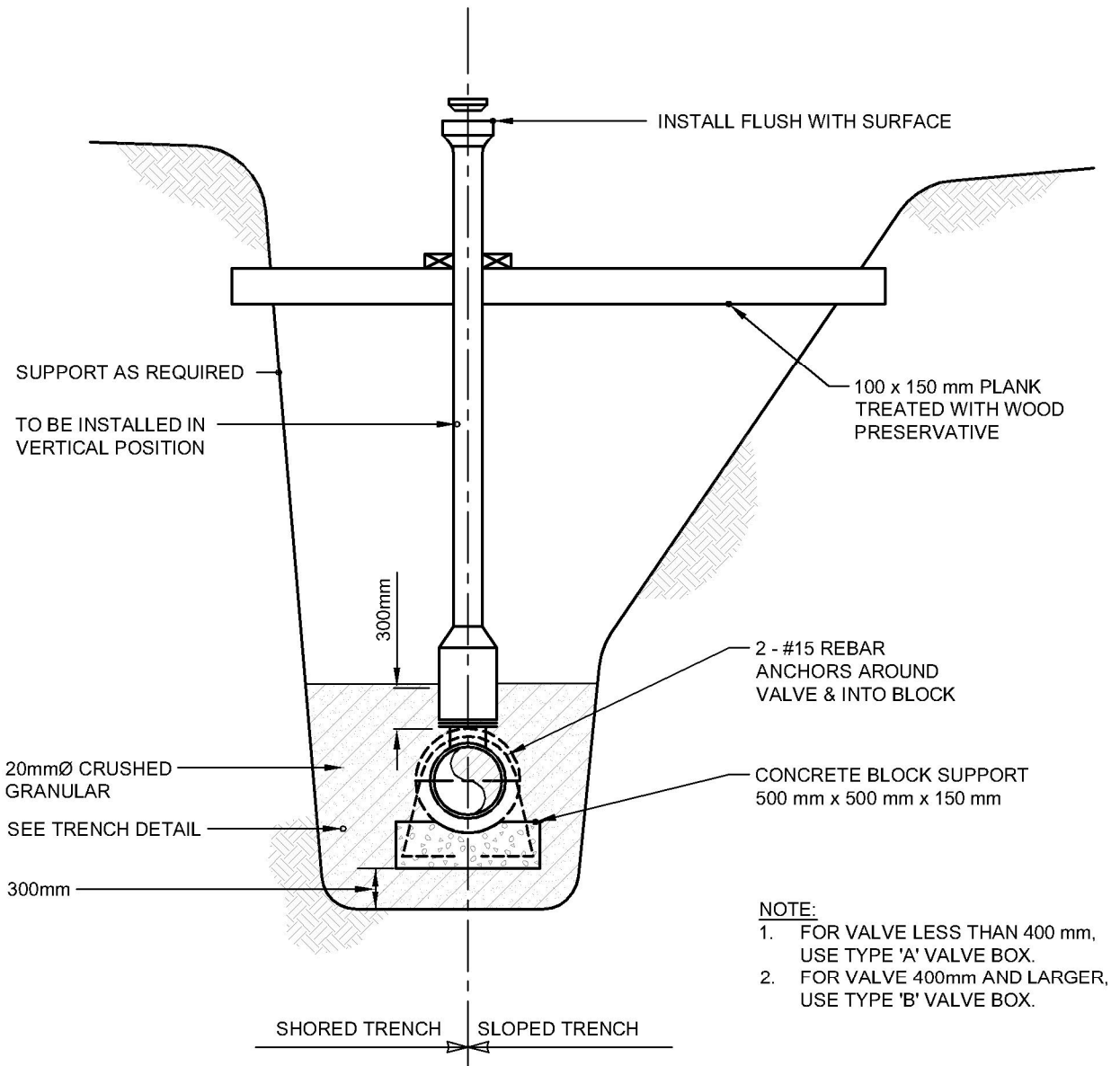

1:50

DATE DRAWN:
01/01/20

REVISION DATE:
06/04/2022

APPROVED BY:

TITLE:

TYPICAL SINGLE VALVE INSTALLATION

WATER

REVISION No.
1

DWG.No.

C-W-128

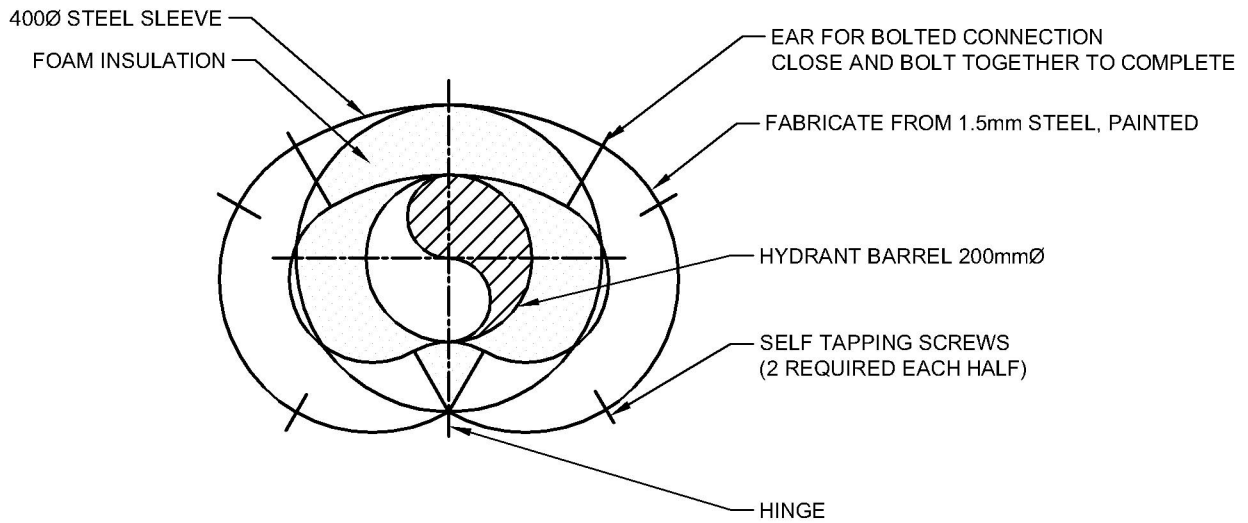

COVER DETAIL

NTS

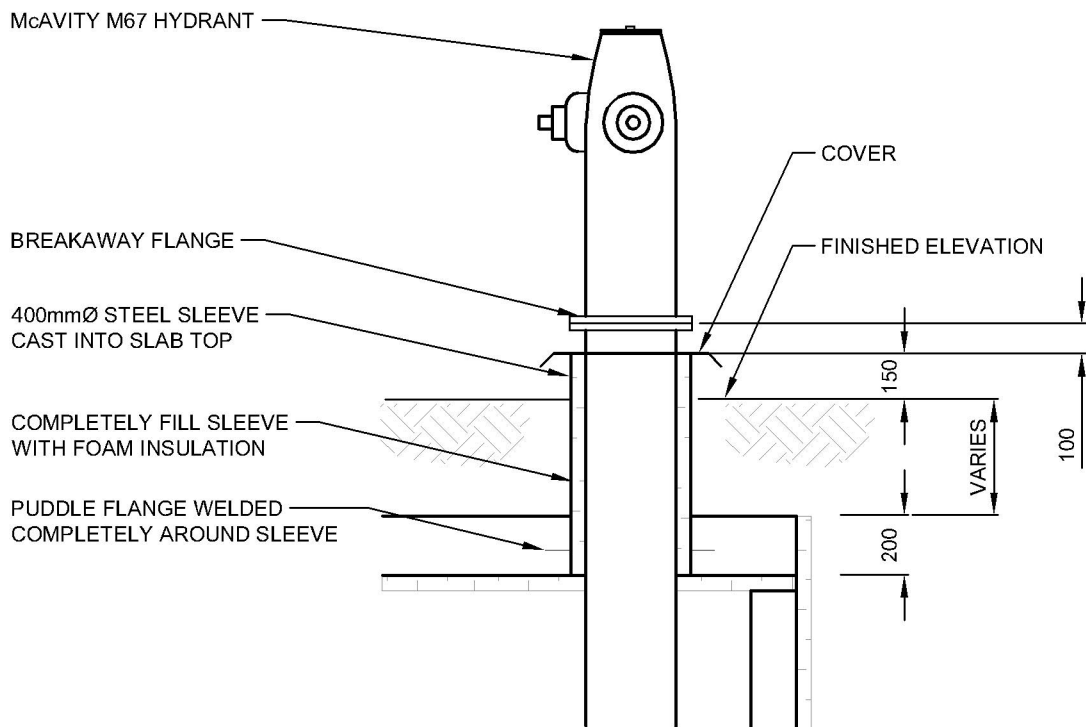

HYDRANT THROUGH ROOF DETAIL

ALL DIMENSIONS IN MILLIMETERS
 UNLESS NOTED OTHERWISE

SCALE 1:25



AS SHOWN

DATE DRAWN:
 01/01/20

REVISION DATE:
 06/04/2022

APPROVED BY:
 YK ENG.

TITLE:

HYDRANT THROUGH ROOF & CONCRETE
 WATER MANHOLE COVER

WATER

REVISION No.
 1

DWG.No.

C-W-129

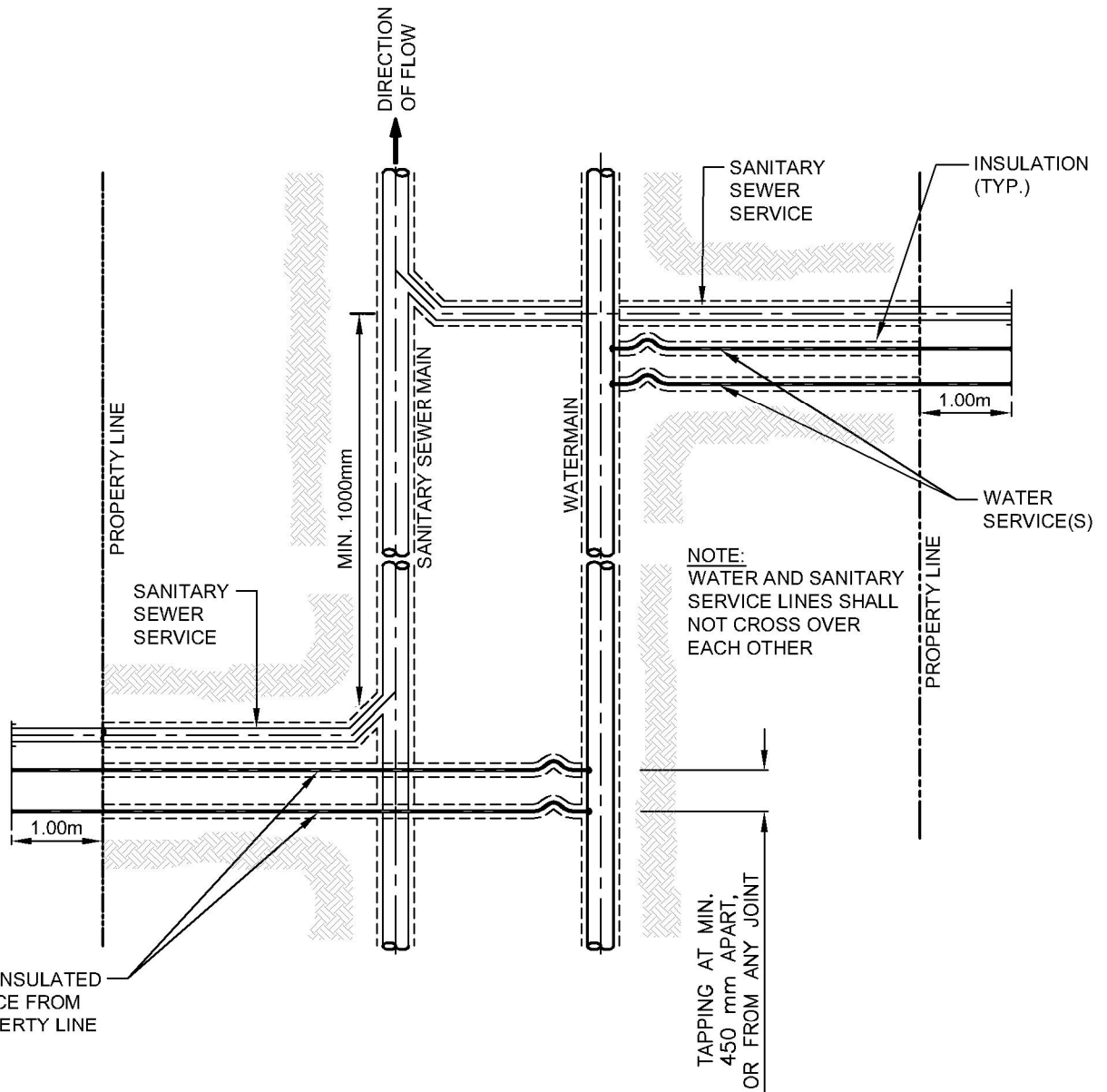

CONTINUOUS INSULATED
WATER SERVICE FROM
MAIN TO PROPERTY LINE

NOTE:
WATER SERVICE PIPE TO BE ONE CONTINUOUS PIECE FROM WATERMAIN
TO 1m PAST PROPERTY LINE. FLARED COPPER TO COPPER CONNECTIONS
ARE TO BE USED ONLY WHEN SERVICE LENGTH EXCEEDS LONGEST
AVAILABLE PIPE LENGTH DUE TO TRANSPORT RESTRICTIONS.



1:75

TITLE:

SERVICE PLAN

DATE DRAWN:

REVISION DATE:

01/01/2020

06/04/2022

APPROVED BY:

YK ENG.

SERVICE

REVISION No.

1

DWG.No.

C-SE-100

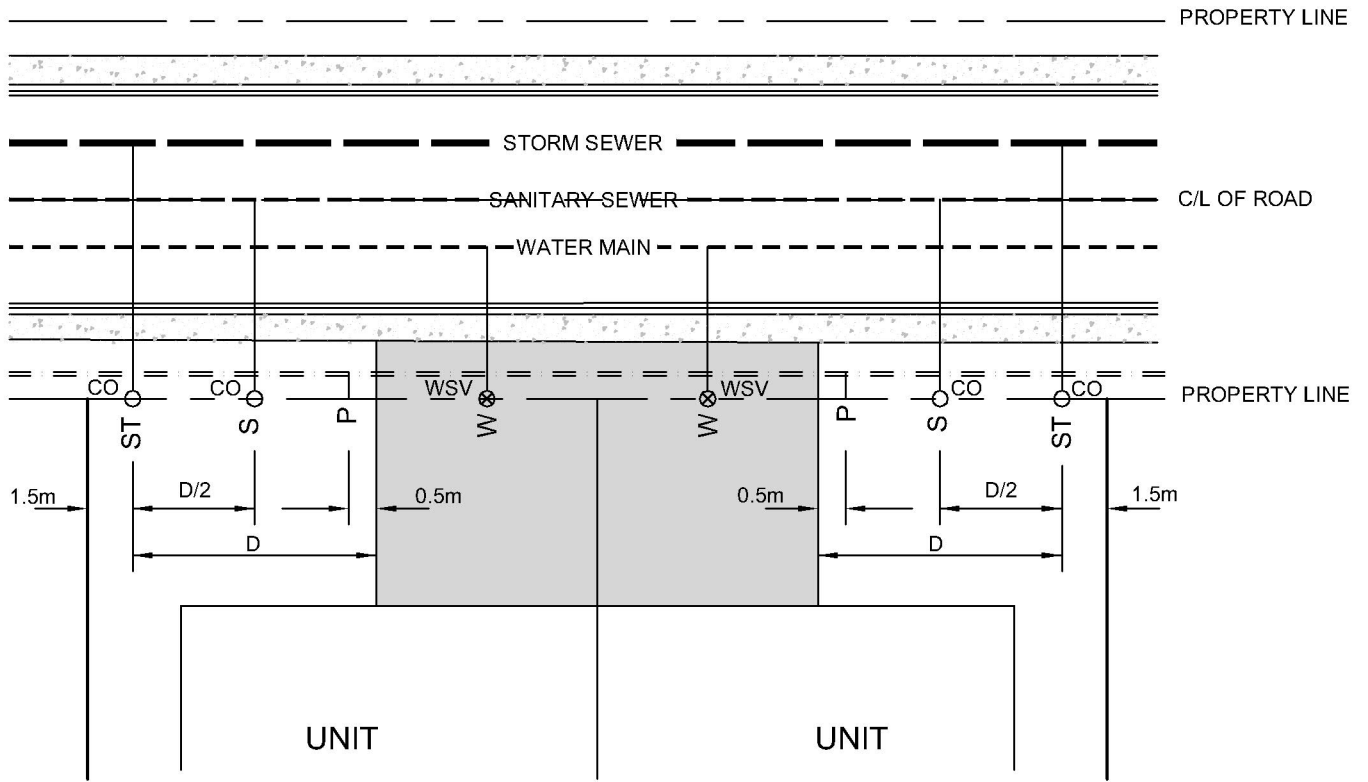

NOTE:
 REFER TO PLAN AND PROFILE SHEETS FOR ACTUAL LAYOUT
 OF STORM SANITARY AND WATER MAIN SERVICES WHICH
 MAY DIFFER FROM THE STANDARD DETAIL SHOWN ABOVE,
 THOSE PLANS SHALL TAKE PRECEDENCE OVER THIS DETAIL.



N.T.S.		TITLE:	
DATE DRAWN: 25/03/2021	REVISION DATE: 06/04/2022	TYPICAL SERVICE AND DRIVEWAY LAYOUT	
APPROVED BY: YK ENG.		SERVICE	REVISION No. 1
			DWG.No. C-SE-101

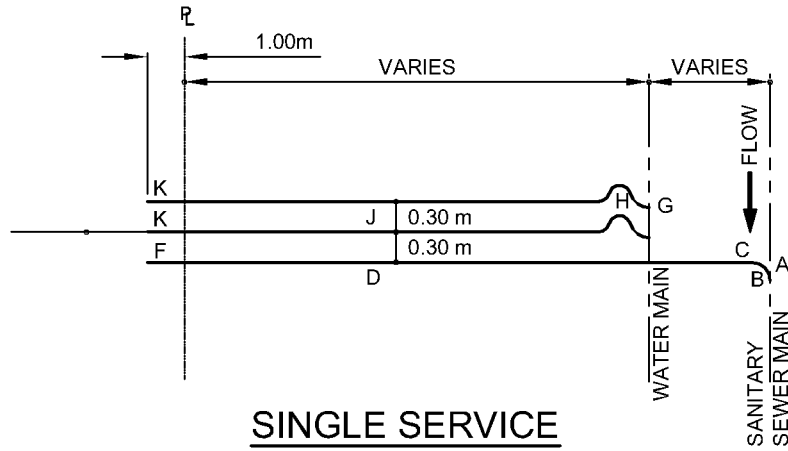

SINGLE SERVICE

NOTES:

1. INSTALL 38 x 89 WOOD POST 2.45m LONG VERTICALLY AT END OF SERVICE.
2. TOP OF POST TO BE 600mm ABOVE GRADE. PAINT ABOVE GRADE RED.

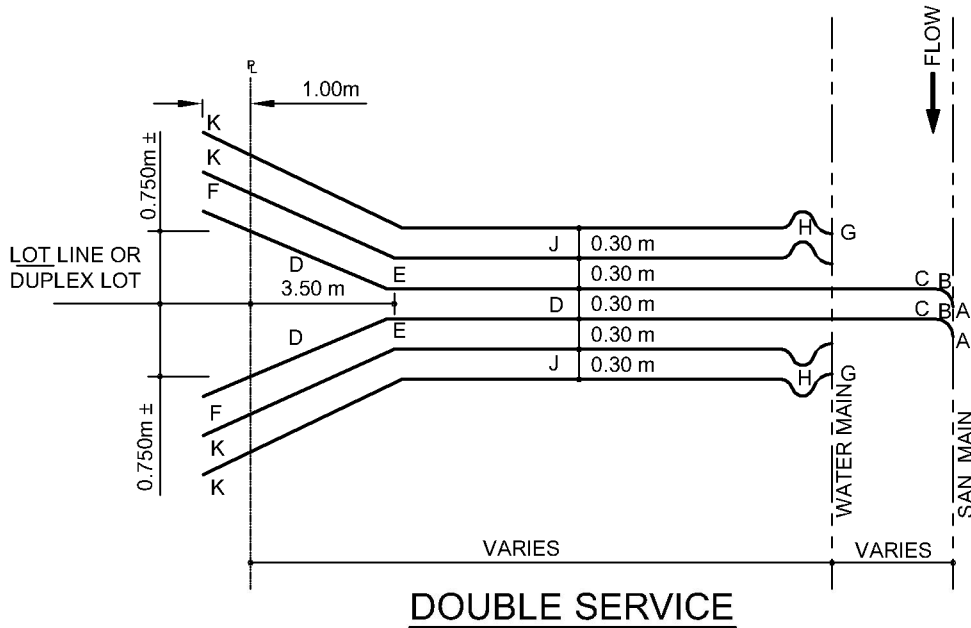

DOUBLE SERVICE

- A - 100 mm SADDLE (D.I.)
- B - STUB PIECE
- C - 45 ° BEND
- D - SANITARY SERVICE
- E - 22 1/2 ° BEND
- F - PLUG OR CAP
- G - 2 - CORPORATION STOPS
- H - 2 - GOOSENECKS, FACTORY INSULATED
- J - 2 - COPPER WATERLINES, FACTORY INSULATED
- K - 2 - GATE VALVES, RED & WHITE

NOTE:

1. NORMAL SERVICES 100 mm DUCTILE IRON SEWER
2. 19 mm COPPER WATER SUPPLY
3. 19 mm COPPER WATER RETURN



1:75

TITLE:

TYPICAL SERVICE CONNECTION TO LOTS

DATE DRAWN:

01/01/20

REVISION DATE:

06/04/2022

APPROVED BY:

YK ENG.

SERVICE

REVISION No.

1

DWG.No.

C-SE-102A

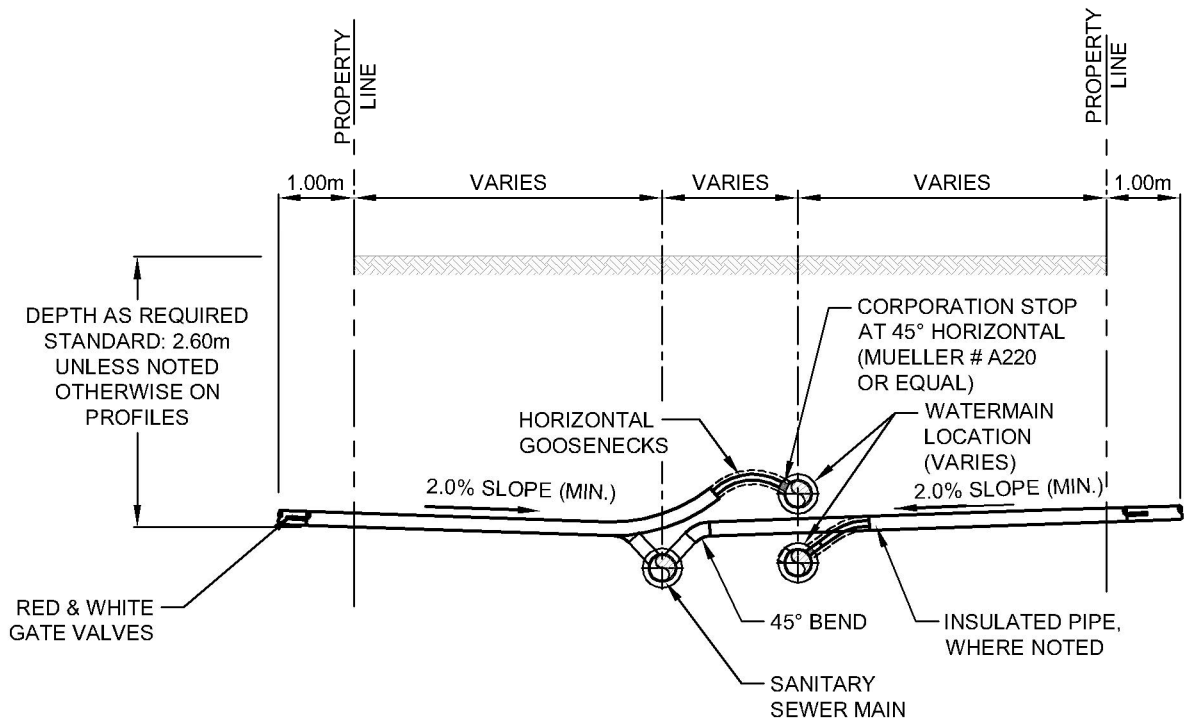

SECTION



N.T.S.

DATE DRAWN:
01/01/20

REVISION DATE:
06/04/2022

APPROVED BY:
D.MCMILLAN

TITLE:

TYPICAL SERVICE CONNECTION TO LOTS

SERVICE

REVISION No.
1

DWG.No.

C-SE-102

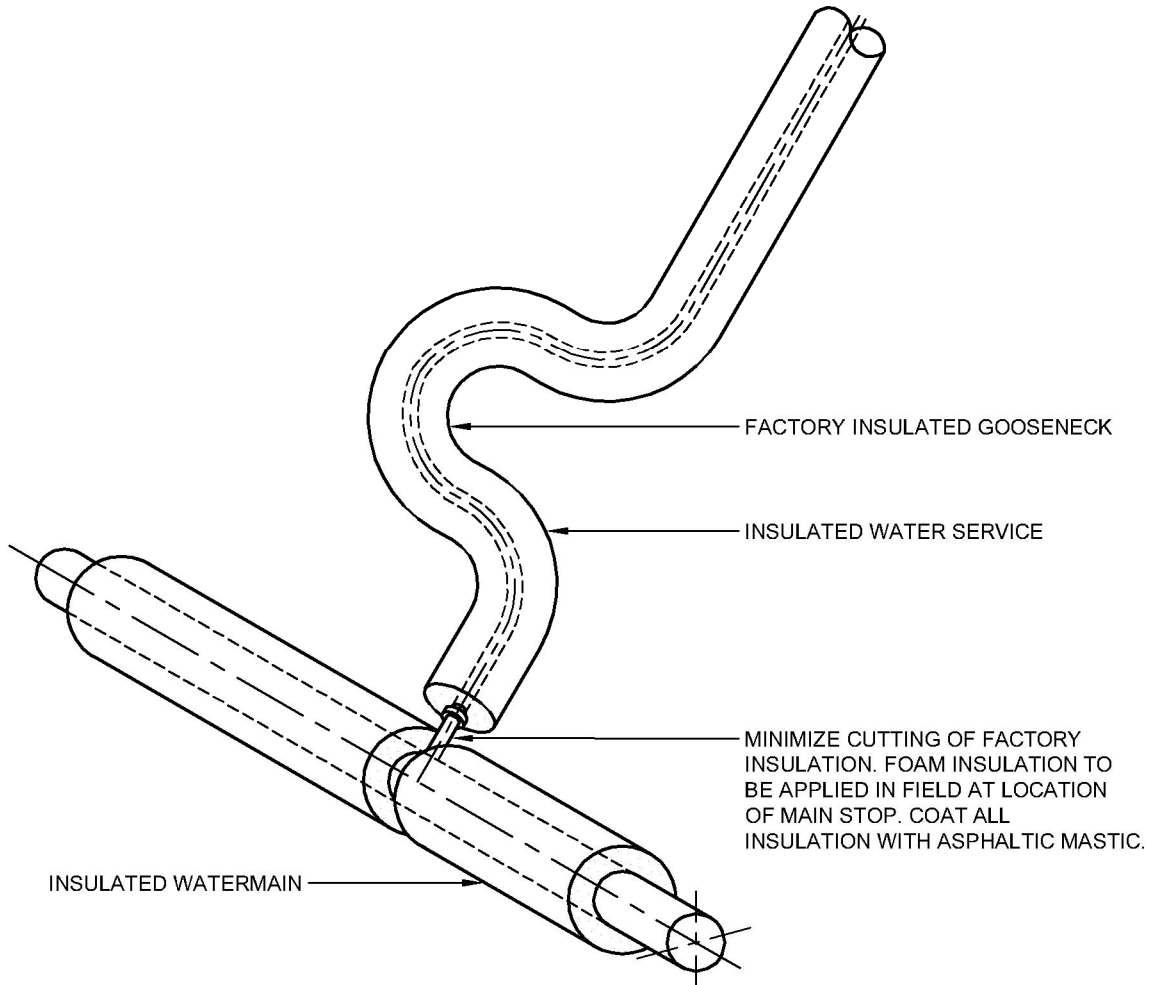

N.T.S.

DATE DRAWN:
01/01/20

REVISION DATE:
06/04/2022

APPROVED BY:
YK ENG.

TITLE:

GOOSENECK MAIN STOP INSULATION AT WATERMAIN

SERVICE

REVISION No.
1

DWG.No.

C-SE-103

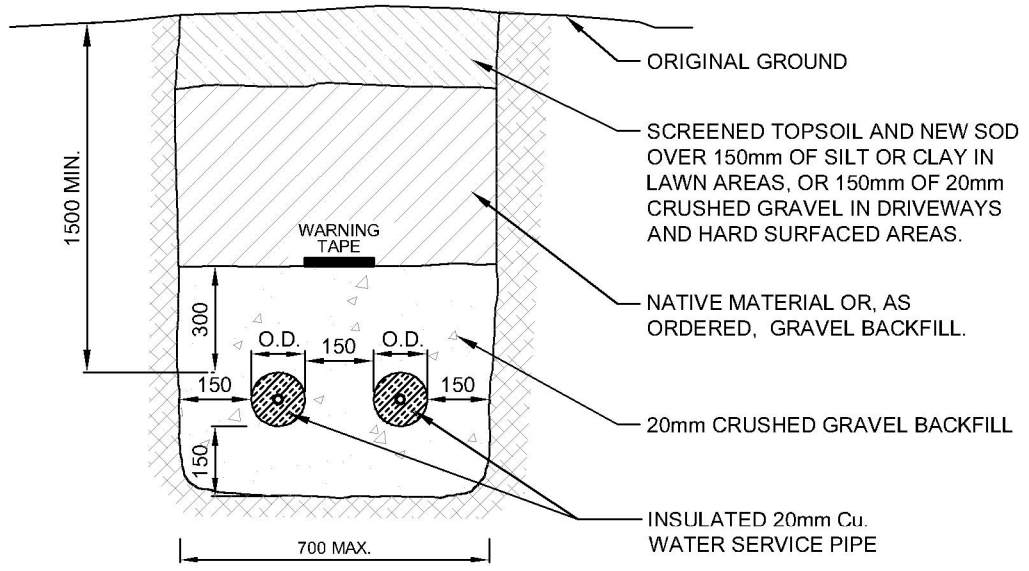

TYPICAL SEPARATE WATER SERVICE TRENCH

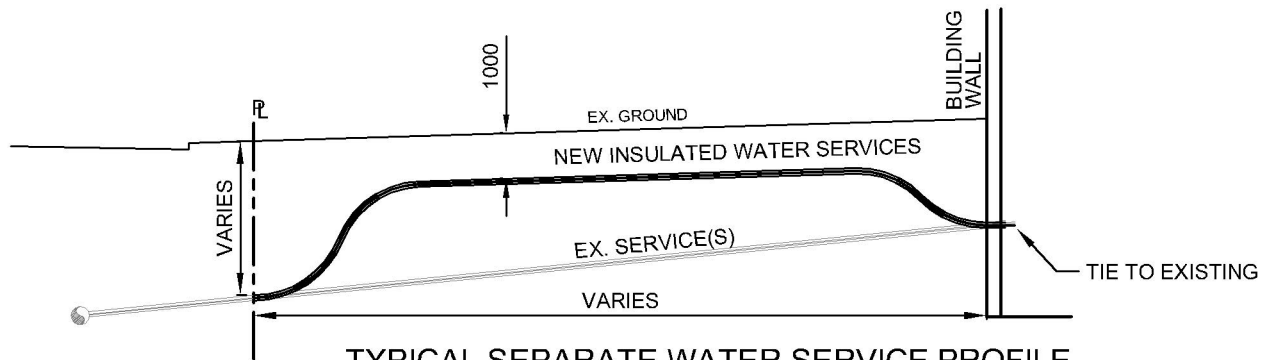

TYPICAL SEPARATE WATER SERVICE PROFILE BASEMENT BUILDING

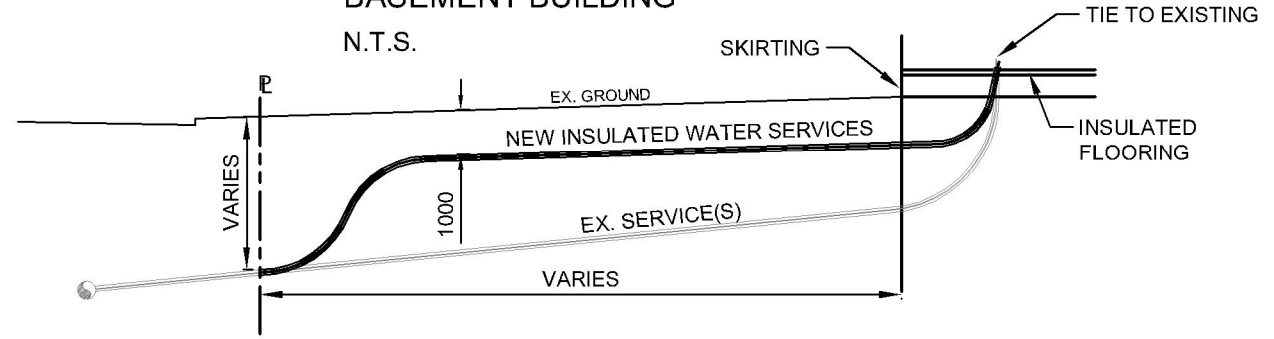

TYPICAL SEPARATE WATER SERVICE PROFILE ABOVE GRADE BUILDING



N.T.S.		TITLE:		
DATE DRAWN: 01/01/20		REVISION DATE: 06/04/2022		
APPROVED BY: YK ENG.		SERVICE		
		REVISION No. 1	DWG.No. C-SE-104	

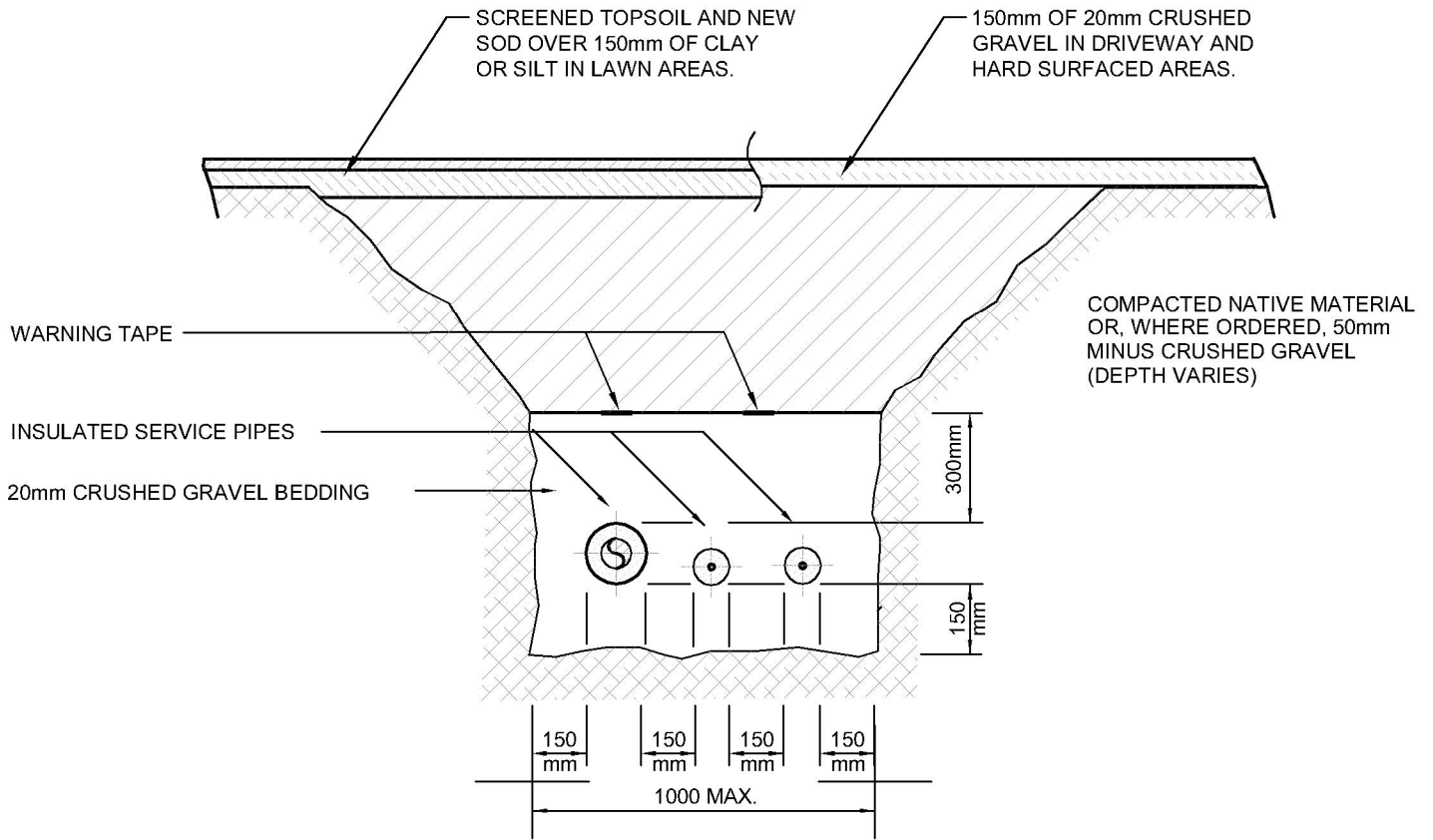

TYPICAL COMBINED WATER/SEWER SERVICE TRENCH DETAIL
(ON PRIVATE PROPERTY)



N.T.S.

DATE DRAWN:
01/01/20

REVISION DATE:
06/04/2022

APPROVED BY:
YK ENG.

TITLE:

**TYPICAL COMBINED WATER-SEWER
SERVICE TRENCH DETAIL**

SERVICE

REVISION No.
1

DWG.No.

C-SE-105

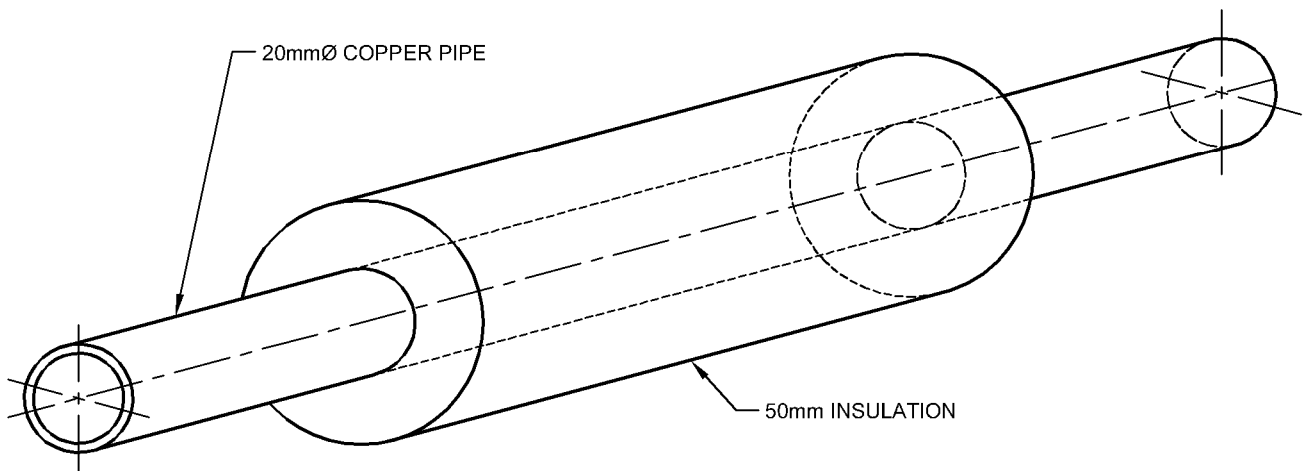

NOTE:

1. ALL WATER SERVICE PIPE TO BE PREINSULATED WITH 50mm INSULATION AND DOUBLE TAPE WRAP AS MANUFACTURED BY URECON OR AS EQUAL.
2. ALL DIMENSIONS IN MILLIMETERS UNLESS NOTED OTHERWISE



N.T.S.

DATE DRAWN:
01/01/20

REVISION DATE:
06/04/2022

APPROVED BY:
YK ENG.

TITLE:

SERVICE PIPE INSULATION DETAIL

SERVICE

REVISION No.
1

DWG.No.

C-SE-106

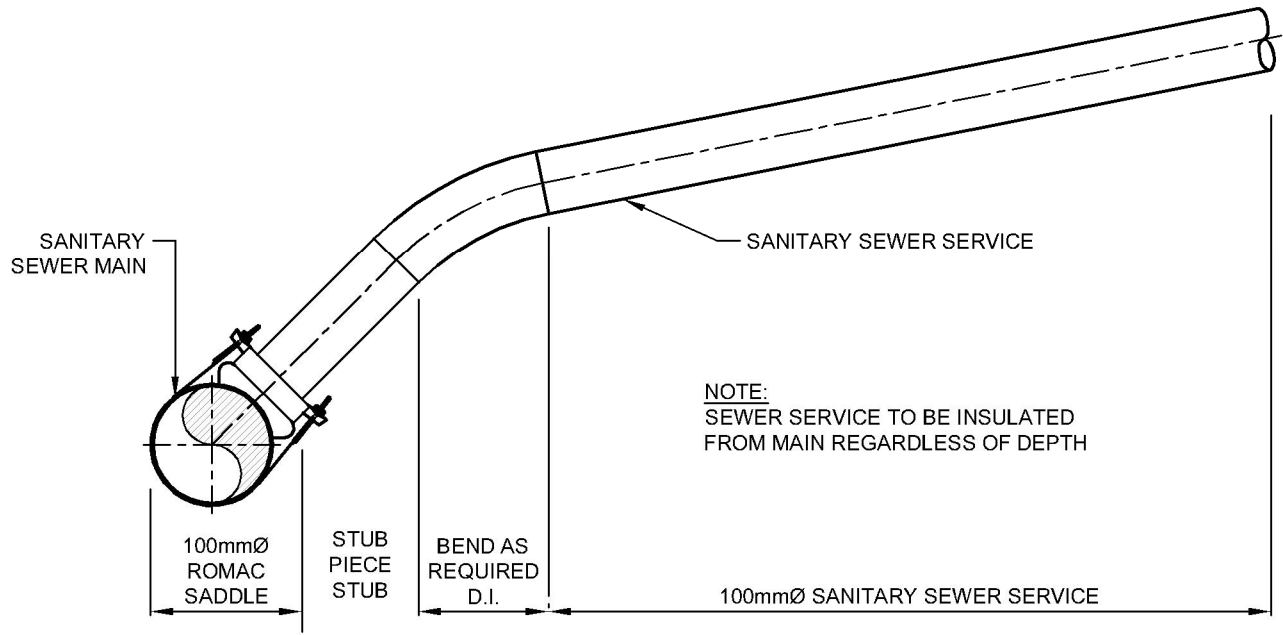

N.T.S.	
DATE DRAWN: 01/01/20	REVISION DATE: 06/04/2022
APPROVED BY: YK ENG.	

TITLE: SANITARY SEWER MAIN AND SERVICE DETAIL		
SERVICE	REVISION No. 1	DWG.No. C-SE-107

SEWER SADDLE MANUFACTURED BY ROMAC INDUSTRIES INC.

SANITARY SEWER MAIN

CENTRE LINE PIPES

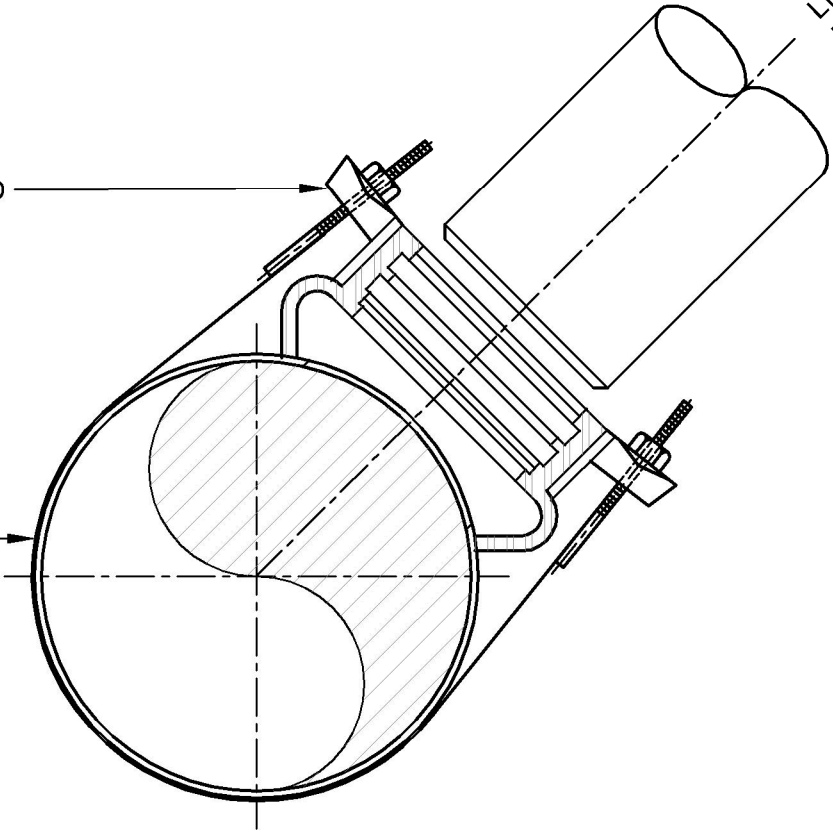

N.T.S.

DATE DRAWN:
01/01/20

REVISION DATE:
06/04/2022

APPROVED BY:
YK ENG.

TITLE:

SANITARY SEWER SERVICE AND
CONNECTION DETAIL







SERVICE

REVISION No.
1

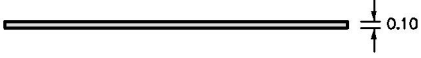
DWG.No.

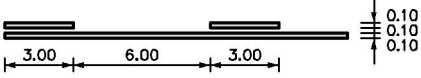
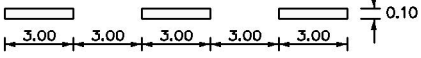
C-SE-108

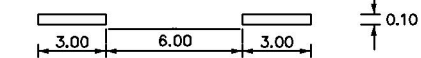
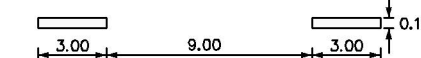
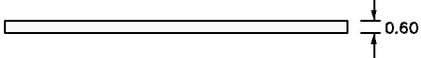
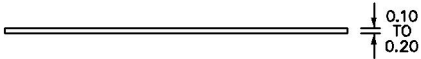
PAVEMENT MARKINGS LEGEND

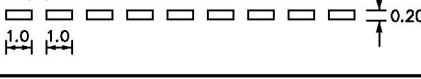
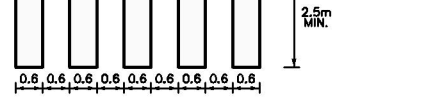
	NAME OF LINE	DIMENSIONS (m)	USE
LONGITUDINAL	(A)		EDGE LINES (WHITE OR YELLOW), DIRECTIONAL DIVIDING LINES (YELLOW) LANE LINES PROHIBITING LANE CHANGES (WHITE)
	(B)		DIRECTIONAL DIVIDING LINES (YELLOW)
	(C)		DIRECTIONAL DIVIDING LINES TWO-WAY LEFT TURN LANES (YELLOW)
	(D)		CONTINUITY LINES (WHITE)
	(E)		GUIDING LINES (E.G. INTERSECTION MOVEMENTS) (WHITE)
	(F)		DIRECTIONAL DIVIDING LINES (YELLOW) URBAN LANE LINES, LOW SPEED (WHITE)
	(G)		LANE LINES (WHITE) HIGH SPEED ROAD
TRANSVERSE	(H)		INTERSECTION STOP LINES (WHITE)
	(I)		CROSSWALKS (WHITE)
	(J)		YIELD LINE (SHARK TEETH) (WHITE)
	(K)		YIELD LINES (E.G. INTERSECTION MOVEMENTS) (WHITE)
	(L)		ZEBRA CROSSWALKS (WHITE)

GENERAL NOTES:

1. ALL DIMENSIONS AND RADII ARE TO CONSTRUCTION BASELINE OR EDGE OF PAVEMENT.
3. ALL ROAD SIGNS TO BE RELOCATED UNDER THE DIRECTION OF THE CITY OF YELLOWKNIFE WORKS DEPARTMENT.
4. TEMPORARY PAVEMENT MARKINGS ON THE BASE COURSE ASPHALT SHALL BE ORGANIC SOLVENT-BASED PAINT INCLUDING REFLECTORIZING GLASS BEADS
5. PAVEMENT MARKINGS ON THE SURFACE COURSE ASPHALT SHALL BE FIELD REACTED POLYMERIC PAVEMENT MARKING MATERIALS HAVING A MINIMUM MARKING THICKNESS OF 2.0mm.
6. PAVEMENT MARKINGS SHALL BE PLACED WITHIN 5 DAYS OF ASPHALT PLACEMENT.
7. TACTILE SURFACE INDICATOR PLATES SHALL BE EJW DURALAST.



N.T.S.

DATE DRAWN: 19/03/2021	REVISION DATE: 06/04/2022
---------------------------	------------------------------

APPROVED BY:
YK ENG.

TITLE:

PAVEMENT MARKINGS LEGEND

PAVEMENT

REVISION No.
1

DWG.No.

PM 100